

The logo for ngmn, featuring the lowercase letters 'ngmn' in a bold, green, sans-serif font. The letters are partially enclosed by a series of thin, grey, concentric, wavy lines that resemble signal waves or a stylized 'n' shape.

the engine of
wireless innovation

A low-angle, upward-looking photograph of a complex telecommunications tower. The tower is constructed from a dense network of red and white metal beams, forming a lattice structure. The sky is a clear, pale blue. A green rectangular box is overlaid on the right side of the image, containing white text.

DEFINITION OF THE TESTING FRAME- WORK FOR THE NGMN 5G PRE-COMMERCIAL NETWORKS TRIALS



DEFINITION OF THE TESTING FRAMEWORK FOR THE NGMN 5G PRE-COMMERCIAL NETWORKS TRIALS

BY NGMN ALLIANCE

DATE: JULY 2019

VERSION 3

Version:	3.0
Date:	JULY -2019
Document Type:	Testing Methodology
Confidentiality Class:	P - Public

LEAD	CEMIL KARAKUS (TURKCELL) [LEAD PRECOMMERCIAL NETWORKS TRIALS]
-------------	---

© 2019 Next Generation Mobile Networks e.V. All rights reserved. No part of this document may be reproduced or transmitted in any form or by any means without prior written permission from NGMN e.V.

The information contained in this document represents the current view held by NGMN e.V. on the issues discussed as of the date of publication. This document is provided "as is" with no warranties whatsoever including any warranty of merchantability, non-infringement, or fitness for any particular purpose. All liability (including liability for infringement of any property rights) relating to the use of information in this document is disclaimed. No license, express or implied, to any intellectual property rights are granted herein. This document is distributed for informational purposes only and is subject to change without notice. Readers should not design products based on this document.

DOCUMENT HISTORY

DATE	VERSION	AUTHOR	CHANGES
19/12/2016	V0.1	HISHAM ELSHAER (VODAFONE)	FIRST DRAFT
25/01/2017	V0.2	YUKSEL YILMAZ (TURKCELL)	SECOND DRAFT
20/03/2017	V0.3	HISHAM ELSHAER	UPDATED ToC AFTER FEEDBACK FROM THE TTI GROUP
18/04/2017	V0.4	HISHAM ELSHAER (VODAFONE)	UPDATED VERSION OF ToC.
05/05/2017	V0.5	HISHAM ELSHAER (VODAFONE)	MINOR CHANGES FROM ORANGE
14/06/2017	V0.6	HISHAM ELSHAER (VODAFONE)	ADDING EDITOR NOTES
10/08/2017	v0.8	YUKSEL YILMAZ (TURKCELL)	ADDING SECTION 5.2 LOCATION/POSITIONING SERVICE
24/08/2017	V0.9	YUKSEL YILMAZ (TURKCELL)	UPDATED VERSION OF LATENCY
25/08/2017	V0.91	PHILIPPE BESSON (ORANGE)	COSMETIC CHANGES ON LATENCY
06/09/2017	V0.10	HISHAM ELSHAER (VODAFONE)	ADDED UPDATES TO SECTIONS 4.2, 4.3, 4.8, 4.9 AND 4.11
20/09/2017	V0.11	HISHAM ELSHAER (VODAFONE)	UPDATING SECTIONS 4.2, 4.3, 4.5 AND 5.3
04/10/2017	V0.12	HISHAM ELSHAER (VODAFONE)	UPDATING SECTIONS 3.2, 4.1, 4.6, 4.10, 4.7 AND 5.2
18/10/2017	V0.13	HISHAM ELSHAER (VODAFONE)	UPDATING SECTIONS 3.1, 4.1, 4.4, 4.6 AND 5.2
20/11/2017	V0.14	HISHAM ELSHAER (VODAFONE)	UPDATING SECTIONS 3.2, 4.1, 4.5, 4.6, 4.8 AND 5.1
28/11/2017	V0.15	HISHAM ELSHAER (VODAFONE)	UPDATING SECTIONS 3.2, 4.1
01/12/2017	V0.16	HISHAM ELSHAER (VODAFONE)	UPDATING SECTION 4.3
11/12/2017	V0.17	HISHAM ELSHAER (VODAFONE)	UPDATING SECTION 3.1, 5.2
12/12/2017	V0.18	ANDRE F.A. FOURNIER (AMPHENOL ANTENNA SOLUTIONS)	PROOF READING, GRAMMAR ERROR CORRECTION AND FORMATTING CORRECTION
20/12/2017	V0.19	HISHAM ELSHAER (VODAFONE)	INTRODUCING REFERENCES AND FIXING HEADERS
21/12/2017	V0.191	PHILIPPE BESSON (ORANGE)	FORMATTING CORRECTIONS
17/01/2018	V0.20	HISHAM ELSHAER (VODAFONE)	FINAL FORMATTING CORRECTIONS
06/02/2018	V0.21	KLAUS MOSCHNER (NGMN)	LOGO CORRECTIONS
26/07/2018	V1.1	CEMIL KARAKUS(TURKCELL)	ADDING SECURITY SECTION, UPDATING SECTION 3.1 & 3.5
03/10/2018	V1.2	CEMIL KARAKUS(TURKCELL)	UPDATING SECTION 3.6
04/10/2018	V1.3	AFRIM BERISA(TURKCELL)	UPDATING SECTION 4.1
31/10/2018	V1.4	CEMIL KARAKUS(TURKCELL)	ADDING SECTION 4.3 VOICE SERVICES
01/11/2018	V1.5	CEMIL KARAKUS(TURKCELL)	SMALL COSMETIC CHANGES
15/11/2018	V1.51	PHILIPPE BESSON (ORANGE)	UPDATING TRANSITION MESSAGE FLOWS
05/12/2018	V2.0	CEMIL KARAKUS(TURKCELL)	LAST CONSOLIDATION AND REVIEW
03/27/2019	V2.1	EHSAN DAEIPOUR(COMMSCOPE)	SECTION 4.3.2 VOICE OVER NR

04/29/2019	V2.2	EHSAN DAEIPOUR(COMMSCOPE)	UPDATES TO SECTION 4.3.2 VOICE OVER NR
04/30/2019	V2.3	EHSAN DAEIPOUR(COMMSCOPE)	CORRECTION TO THE VoNR CALL FLOW.
04/30/2019	V2.4	ANDRE F.A. FOURNIER (AMPHENOL ANTENNA SOLUTIONS)	CORRECTED ERROR MESSAGE IN SECTION 3.8.1.2 AND 3.11.1.1. THE REFERENCE TO THE RELATED FIGURE WAS MISSING
07/05/2019	V2.5	CEMIL KARAKUS (TURKCELL)	UPDATES TO SECTION 3.2 PEAK THROUGHPUT AND 3.5 COVERAGE
07/16/2019	V3.0	CEMIL KARAKUS(TURKCELL)	LAST CONSOLIDATION AND REVIEW

List of contributing, reviewing and supporting companies



Table of Contents

ngmn e. V.

Großer Hasenpfad 30 • 60598 Frankfurt • Germany

Phone +49 69/9 07 49 98-04 • Fax +49 69/9 07 49 98-41



Introduction.....	6
1 Scope.....	7
2 Trial setup requirements	8
2.1 General requirements.....	8
2.1.1 Deployment setup.....	8
2.1.2 Traffic requirement.....	8
2.1.3 Trial Network Setup and IP configuration.....	8
2.1.4 Reporting requirement	9
2.1.5 Security configurations	10
2.2 Deployment scenarios.....	11
2.2.1 Indoor hotspot.....	11
2.2.2 Dense Urban	13
2.2.3 Urban Macro.....	14
2.2.4 Rural	15
2.2.5 High speed	16
2.3 UE test devices calibration	17
2.4 UE pre-trial testing	17
2.5 BS pre-trial testing	18
3 Trial test requirements	19
3.1 Latency	19
3.1.1 Control plane latency	19
3.1.2 User plane latency	25
3.2 User Throughput	29
3.2.1 Peak throughput.....	30
3.2.2 Throughput at interference limited cell edge.....	32
3.2.3 Cell edge coverage throughput.....	35
3.2.4 Throughput in different coverage conditions (link budget test).....	37
3.2.5 Throughput in different interference conditions (Average User Throughput).....	39
3.3 Cell capacity.....	43
3.3.1 Cell peak throughput	43
3.3.2 Cell average throughput.....	45
3.4 Spectral efficiency.....	48
3.4.1 Definition	48
3.4.2 Test environment.....	48
3.4.3 Success criteria	48
3.5 Coverage.....	49
3.5.1 Outdoor Single-cell Coverage	50
3.5.2 Outdoor Multi-Cell Continuous Coverage	53
3.5.3 Outdoor to Indoor Coverage.....	55
3.5.4 Indoor Coverage	56
3.6 Mobility	58
3.6.1 Intra-Cell mobility testing.....	58
3.6.2 Inter-Cell Mobility (Handover) Testing.....	60
3.7 Reliability and Retainability.....	67
3.7.1 Definition	67
3.7.2 Test Environment	67
3.7.3 Success criteria	69
3.8 User experience	70
3.8.1 Definition	70



3.8.2	Test environment.....	73
3.8.3	Success criteria	85
3.9	Energy efficiency	88
3.9.1	UE energy efficiency.....	88
3.9.2	Network energy efficiency.....	89
3.10	Inter-RAT procedures.....	93
3.10.1	NSA Inter-RAT Mobility with PS Service.....	93
3.10.2	SA Inter-RAT Mobility with PS Service.....	95
3.11	RAN architecture split	97
3.11.1	CU-DU Separation	98
3.11.2	CP-UP Separation	100
4	Service or technology specific requirements.....	103
4.1	Location/Positioning service	103
4.1.1	EPS Scenario (Option 3).....	103
4.1.2	5GS Scenario (NG-RAN).....	103
4.2	Fixed wireless access	108
4.2.1	Definition	108
4.2.2	Test environment.....	109
4.2.3	Success criteria	110
4.3	Voice Services.....	112
4.3.1	EPS Fall-back	112
4.3.2	Voice Over NR.....	115
5	Abbreviations	122
6	References.....	123



Introduction

The Next Generation Mobile Networks (NGMN) Alliance (see www.ngmn.org) was founded by leading international network operators in 2006. Its objective is to ensure the functionality and performance of next generation mobile network infrastructure, service platforms and devices meet the operators’ requirements and, ultimately, satisfy end user demand and expectations. The NGMN Alliance will drive and guide the development of all future mobile broadband technology enhancements with a focus on 5G. The targets of these activities are supported by the strong and well-established partnership of worldwide leading operators, vendors, universities, other industry players (like software companies, vertical industry representatives) and by successful co-operations with industry organizations.

In February 2015 the NGMN Alliance published its 5G White Paper 6 providing a consolidated 5G operator requirements. Subsequently in 2016, NGMN published a number of deliverables detailing the requirements and architecture as well as business principles, including views of vertical industry applications. In June 2016, NGMN started a further extension of its 5G-focused work-programme with the launch of new additional work-items for the coming years: 5G Trial & Testing Initiative (TTI), End-to-end Architecture Framework, and the V2X Task-Force. The Trial and Test Initiative Mission can be summarized as below:

- Enable global collaboration of testing activities to support an efficient, successful, and in-time 5G technology and service introduction
- Consolidate contributions and report on industry progress in order to ensure the development of globally aligned 5G technology and service solutions
- Identify, test, and promote new business opportunities and use-cases with industry stakeholders (e.g. from vertical industries)

The TTI consists of four phases summarized as follows:

- **Tests of technology building blocks** (e. g. Massive MIMO, new waveforms...) and possible pre-5G tests the member companies may be individually conducting during the pre-5G deployment period.
- **Proof of concept (PoC)** of the basic features of the radio interface, core network and 5G architectural components. The PoC may be performed using solutions which may be partially proprietary; however, this phase necessitates using the basic concepts of the 5G radio interface as specified by the Third Generation Partnership Project (3GPP).
- **Interoperability phase** which includes testing of the network aspects and device/network interoperability.
- **Pre-commercial networks trials** with equipment close to the commercial ones. This phase focuses on the initial planning phase (including test specifications), followed by the actual trials (with pre-commercial equipment installed on sites).

This document focuses on the pre-commercial network trials phase which has the following scope:

- Developing a testing framework for 5G New Radio (NR), as developed by 3GPP, allowing the harmonization of the testing methodologies between the different parties conducting trials.
- Devising a strategy for the trials activities to guarantee efficiency and success of the different trials activities.
- Testing 5G capabilities in realistic conditions with pre-commercial equipment.

The milestones and timelines for this phase are specified in Table 2.1-1-1: NGMN Trial Milestones and Figure 1-2.1-1.

Milestones	<ul style="list-style-type: none"> • M5.1: Initial version of trial framework finished. • M5.2: Beginning of pre-commercial trial network installation. • M5.3: Final version of trial framework finished. • M5.4: Completion of initial testing & documentation (for input to 3GPP). • M5.5: Completion of testing & documentation.
-------------------	--

Table 2.1-1-1: NGMN Trial Milestones

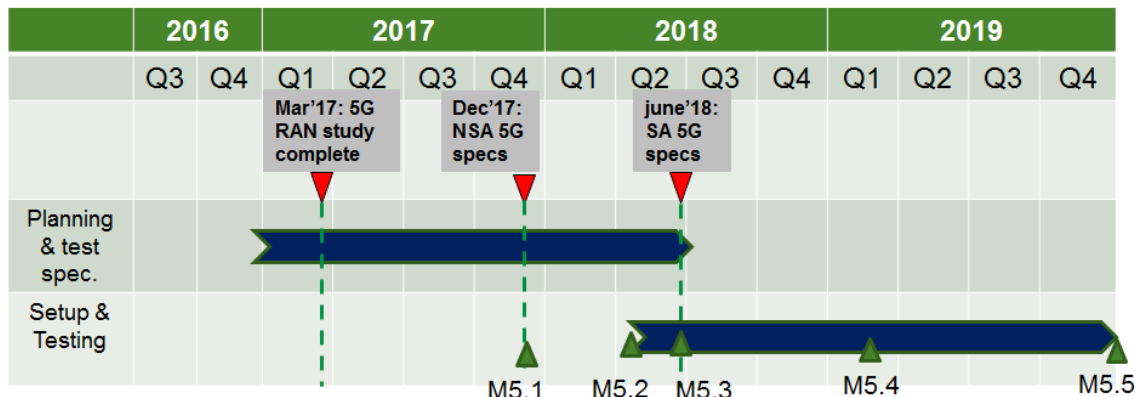

Figure 1-2.1-1 :- NGMN Trial Milestones

1 Scope

The focus of this document is to evaluate the performance of 5G new radio (NR) which is based on the 3GPP standard. The main purpose of this document is to assess and benchmark the performance of the 3GPP compliant 5G NR. Initially the focus is on phase 1 (release 15) of the 5G NR standardisation which focuses on enhanced mobile broadband (eMBB) and some aspects of ultra-reliable low latency communications (URLLC).

This first version of the document will address the non-standalone (NSA) version of 5G NR and some aspects of standalone (SA)¹. The second version of the document (due by mid-2018) will address the rest of the SA specifications.

The focus of the testing will be on the radio interface except for some key performance indicators (KPIs) and features that need to be quantified in an end-to-end configuration (e.g. Latency, network slicing...).

The performance of 5G NR will be compared² against target requirements and predicted performance defined in 3GPP, the NGMN 5G white paper and other sources which define the PASS/FAIL threshold for each test.

This framework document is structured in three parts:

1. Trial setup requirements
2. Trial test requirements
3. Service or technology specific requirements

The trial setup requirements section defines the key parameters for the setup of the pre-commercial field trials, consisting of the main deployment scenarios and the reporting and benchmarking requirements.

The test requirements section defines the KPIs and executable proof points. Every test/KPI should include a definition, test configuration, the success criteria and most importantly a clear testing methodology.

The service or technology specific requirements section defines test procedures and configurations for specific services or technologies such as positioning and fixed wireless access.

¹ The NSA version of 5G NR was delivered by 3GPP in December 2017 while the SA specifications is expected by mid-2018.

² The comparison should be within similar conditions and using the same or adjacent frequency band as a comparison between 5G NR in 26/28 GHz and Long term evolution (LTE) in sub-6GHz is not very interesting.

2 Trial setup requirements

This chapter specifies the deployment scenarios including the used frequency bands and all the practical considerations for each deployment scenario.

2.1 General requirements

The pre-commercial trials will primarily aim at testing 5G NR using close to commercial equipment in realistic settings that would reflect near real life network performance. Below are some general requirements to ensure that the trials reflect a realistic environment for meaningful results.

2.1.1 Deployment setup

The trials will cover a wide range of deployment scenarios including indoor/outdoor and macro/small cells deployments. The minimum number of cells/sites³ will vary depending on the deployment scenario and the nature of the test. The important aspects to achieve would be to have enough sites to fulfill the following:

- Areas with excellent signal to noise ratio (SNR) and negligible interference for peak performance measurements.
- Areas with poor SNR for minimum performance measurements.
- Areas with low to very high interference for realistic interference measurements.

For a dense urban macro deployment, the minimum number sites would be different than in an indoor or rural environment in order to achieve the above.

Since the first drop of the 3GPP NR standards will be a non-standalone (NSA) architecture, the trials need to consider collocated and non-collocated NR and LTE radio suites to test the dual connectivity between both technologies.

Inter-network elements distances should be close to real operational distances (e.g. Radio – Core Network – Servers). Notably the backhaul distances (over several km) should be indicated in the trial reports for ensuring a fair assessment of Latencies.

2.1.2 Traffic requirement

Generating a realistic traffic load in the trial is essential for meaningful results. However, the number of available test user equipment (UE) is always a limiting factor. Therefore, generating artificial load and interference transmission can be used to limit the number of UEs.

2.1.3 Trial Network Setup and IP configuration

A typical 5G pre-commercial trial network is similar to the one shown in section 3.1.2.1. It consists of:

- access domain, the aggregation domain (in this case this is where the multi-access edge computing (MEC) option and the virtualized base band unit (vBBU) are located),
- the core network (evolved packet core (EPC) or next generation core (NGCore))
- the application server.

The IP configuration for the trial network can be left for each operator to set up according to their local or remote IP network configuration. However, in order to ensure comparable test results in terms of throughput and latency between various trials, some common IP configurations for the applications used in the trial must be utilized. For this purpose, the IP configuration between the UE (and the host operating system running the application) and the application server is common. The following are guidelines to ensure this common setup.

- The main IP configuration parameters for TCP are shown in table 2.1-1.

³ The number of cells/sites would depend on the nature of the test as some tests could be done with a fewer number of cells (e.g. coverage) whereas others would require many more cells/sites.



- The assumed operating system for the host application used in the trial setup at the UE side is Windows 7.
- The optimum TCP receive window (RWin) depends on the latency and the bandwidth of the underlying connection between the application server and the UE.
- In a trial there are varying expectations for the latency and bandwidth depending on the service, e.g. eMBB and URLLC, and the deployment scenario.

The target latency and bandwidth for each of these deployment scenario are as follows.

- E2E Latency for the eMBB use case is less than 15ms.
- E2E latency for URLLC use case is less than 3ms.
- The expected bandwidth for wide area deployment in below 6GHz with Channel bandwidth of 100MHz is 3Gbps/1.5Gbps for DL/UL.
- For local area deployment in mmWave (>6GHz) with channel bandwidth of 800 MHz is over 20Gbps for DL.

With such varying E2E latency, there is no fixed optimum value for setting the RWin parameter. As such, it is therefore recommended that the RWin is estimated according to the following formula and it should be reported with the test result in order to allow comparison and analysis of the test results.

The optimum RWin is best setup based on the latency in the network according to the following formula.

To use the PING (Packet InterNet Groper) tool to find the optimal RWIN Size, ping your ISP with the Max Transfer Unit(MTU) size.

$$\text{Bandwidth(kbps)} / 8 * \text{Average Latency(msec)} = \text{RWIN Size(Bytes)}$$

The average latency can be obtained using the PING function with the following setting

PING “@IP” -f -l <MTU-28> -n 10 where the @IP is the application server IP address.

Note: The -28 is because of the IP- and ICMP-Header which the PING tool adds.

Parameters	Value set at application server	Value set a the UE PC
Operating System		Windows 7
TCP receiving windows size (RWin)		[according to the formula above]
Default sent window		Consistent with RWin
MTU size	1446	1446
Selective Acks		Yes
Max duplicate Acks		2

Table 2.1-1: - E2E Latency parameters

Once the RWin is estimated, the following settings are recommended.

- Use the same MTU value at both sides to limit the impact of fragmentation and de-fragmentation processes on latency.
- At server side the sending window should be set at a value above the RWIN
- When possible, at FTP server side:
 - Ensure Tx socket size is \geq RWIN (of the receiving side)

Ensure internal buffer size is set to a low value (Around 10 % of Tx socket size)

2.1.4 Reporting requirement

The trial reporting is a very important step and having enough details on the different trials will ensure meaningful benchmarking and comparison of the results. Hence, partners are encouraged to provide as many details as possible about their trials. The following aspects need to be covered in the trial reporting.

ngmn e. V.

Großer Hasenpfad 30 • 60598 Frankfurt • Germany

Phone +49 69/9 07 49 98-04 • Fax +49 69/9 07 49 98-41

2.1.4.1 Trial setup information

The following deployment parameters need to be reported for each trial:

- Carrier frequency
- Operating bandwidth
- Duplex mode (e.g. FDD, TDD).
- Sub-carrier spacing.
- Carrier prefix.
- Slot length.
- Number of sites and test UEs.
- Type of environment (dense urban, urban, rural...)
- Site locations including coordinates and height information and a map with the site layout.
- Test UEs location and height information.
- BS and UE transmit power and antenna gain.
- BS and UE antenna configuration (number of antennas, layout).
- BS and UE number of supported MIMO layers.
- Traffic type used for the trial.

2.1.4.2 Trial result information

The counters to be logged at the BS and UE sides are specified for each test case in sections 3 and 4.

2.1.4.3 Trial result benchmarking

Defining the benchmarks to quantify the performance of 5G NR is very crucial to have a meaningful baseline for benchmarking and allows a meaningful performance gain characterization. Using LTE Rel. 14 as a benchmark⁴ is an option and helps in understanding the performance gains of Rel. 15 NR compared to the previous release (Rel. 14). In addition, using LTE Rel.15 as benchmark also helps quantifying the gains of NR as compared to LTE of the same release. Ideally, the benchmark is based on trial results with the same setup. However, a different trial setup could be acceptable as long as the differences between the two systems are well described and accounted for. Finally, simulation results may be used as a benchmark if trial results are not available.

2.1.5 Security configurations

It is proposed to run the NGMN TTI tests in 2 states or experimental conditions:

- **“Configuration 1”**, the default configuration.
A default configuration / security profile with all relevant security features activated, representing the baseline for the NGMN TTI tests. By relevant features we, refer to all “should” security features enabled (reference 3GPP TS 33.501 or TS 33.401).

Operators are invited to report on the implementation of options listed here:

- Backhaul / midhaul security features are enabled if the network is not deemed to be inherently secure.
- IP network and core network security features are enabled (ACL filtering, source IP address validation for anti-spoofing, filtering of peer to peer traffic according to local regulations).

Variants / Operator options:

- Configuration 1.1: the network is deemed to be inherently secure, no IPSEC Gateways for the security of backhaul or midhaul.
- Configuration 1.2: the network is not deemed to be inherently secure, IPSEC Gateways are used for the security of backhaul or midhaul.

⁴ The maturity level of pre-commercial NR UE, network and chip may affect the results.



- “**Configuration 2**”, the basic configuration.
A basic security profile, where all 'must' security features are enabled (Reference 3GPP TS 33.501 or TS 33.401).
Additionally, “optional” features are disabled.

“**Configuration 1**” is considered as the default configuration where we check the pass or fail result of the NGMN TTI test. This supports the philosophy that any recommendation in the 3GPP standard, whether it is identified as mandatory or optional, should not degrade the performance of the network.

“**Configuration 2**” is considered for measuring the impact of the security features on the results of the NGMN TTI tests. It would highlight the difference in performance between the recommended security features and the minimum security features of the architecture.

RAN, Core Network equipment and infrastructure security features are enabled in a multi-vendor configuration. No additional security features recommended by vendors/suppliers should be included.

NGMN TTI’s primary interest is on NSA (options 3, 3a to 3x). The proposed methodology is agnostic to the architecture options.

It is suggested to report on features settings that are used, such as:

- security algorithms (SNOW, AES, ZUC)
- default security algorithms to be used, when the UE does not indicate its preferences in security negotiation procedure (SNOW, AES, ZUC)
- frequency/periodicity of authentication
- validity periods of temporary identifiers (GUTI, 5G GUTI)
- IMEI verification
- key handling in handovers
- periodic local authentication, key refreshes
- privacy of SUPI
- Security Gateways (S1, X2, F1/E1, N2, N3, Xn)
- Security parameters in UE (including, the visibility and configurability of these parameters according to user preferences)
- the security parameters in network equipment (NE) or network functions (NF)
- the timings/timers used by 3GPP security procedures
- the location and configuration of IPSEC gateways (physical or virtual gateways, when IPSEC gateways are in use)
- the IP connectivity provided by the network
- the distances of network elements/functions to the IPSEC gateways

2.2 Deployment scenarios

Twelve deployment scenarios are addressed in [2] for eMBB, URLLC, massive machine type communication (mMTC) and enhanced vehicle to everything (eV2X) services.

For eMBB and URLLC services, the below five scenarios are considered in this document.

2.2.1 Indoor hotspot

This section focuses on high user density and high capacity/throughput in indoor small coverage areas.

Scenario specific deployment attributes and expected values are listed in Table 2.2-3.

ngmn e. V.

Großer Hasenpfad 30 • 60598 Frankfurt • Germany

Phone +49 69/9 07 49 98-04 • Fax +49 69/9 07 49 98-41

Attributes	Expected Values
Carrier Frequency	Sub 6 GHz and above 6 GHz (around 30 GHz & 70 GHz)
Aggregated system bandwidth	100 MHz for sub 6 GHz 800 MHz for above 6 GHz (around 30 GHz & 70 GHz)
Sub-carrier spacing	eMBB: 30 kHz for sub 6 GHz 120 kHz for above 6 GHz URLLC: 60(30) kHz
Carrier Prefix (CP) length	2.3us for eMBB 1.2us for URLLC
Slot length	eMBB: 0.5ms (14 symbols), 0.25ms (7 symbols) (Optional: mini-slots) for sub 6 GHz 0.125ms for above 6 GHz URLLC: 0.125ms
Number of Layers	1
BS antenna elements	Up to 256 Tx and Rx antenna elements (64 or 128 is recommended) for sub 6 GHz Up to 256 Tx and Rx antenna elements for above 6 GHz (around 30 GHz & 70 GHz)
UE antenna elements	Up to 8 Tx and Rx antenna elements (4 is recommended) for sub 6 GHz Up to 32 Tx and Rx antenna elements for above 6 GHz (around 30 GHz & 70 GHz)
User location and speed	100% Indoor, 3km/h
Traffic Type	Full buffer traffic or non-full-buffer traffic depends on the scenario
Inter Site Distance	20m

Table 2.2-2.2-1 :- Indoor hotspot Deployment Attributes

2.2.2 Dense Urban

This section focuses on high user density and high traffic loads in city centres with outdoor and outdoor to indoor coverage scenarios. Scenario specific deployment attributes and expected values are listed in table 2.2-2.

Attributes	Expected Values
Carrier Frequency	Sub 6 GHz and above 6 GHz (around 30 GHz)
Aggregated system bandwidth	100 MHz for sub 6 GHz 800 MHz for above 6 GHz (around 30 GHz)
Sub-carrier spacing	eMBB: 30 kHz for sub 6 GHz 120 kHz for above 6 GHz URLLC: 60(30) kHz
CP length	2.3us for eMBB 1.2us for URLLC
Slot length	eMBB: 0.5ms (14 symbols), 0.25ms (7 symbols) (Optional: mini-slots) for sub 6 GHz 0.125ms for above 6 GHz URLLC: 0.125ms
Number of Layers	2
BS antenna elements	Up to 256 Tx and Rx antenna elements (64 or 128 is recommended) for sub 6 GHz Up to 256 Tx and Rx antenna elements for above 6 GHz (around 30 GHz)
UE antenna elements	Up to 8 Tx and Rx antenna elements (4 is recommended) for sub 6 GHz Up to 32 Tx and Rx antenna elements for above 6 GHz (around 30 GHz)
User location and speed	80% Indoor (3km/h) and 20% outdoor (30km/h)
Traffic Type	Full buffer traffic or non-full-buffer traffic depends on the scenario
Inter Site Distance	200m

Table 2.2-2 :- Dense Urban Deployment Attributes

2.2.3 Urban Macro

This section focuses on continuous coverage in urban areas.

Scenario specific deployment attributes and expected values are listed in Table 2.2-33.

Attributes	Expected Values
Carrier Frequency	Sub 6 GHz and above 6 GHz (around 30 GHz)
Aggregated system bandwidth	100 MHz for sub 6 GHz 800 MHz for above 6 GHz (around 30 GHz)
Sub-carrier spacing	eMBB: 30 kHz for sub 6 GHz 120 kHz for above 6 GHz URLLC: 60(30) kHz
CP length	2.3us for eMBB 1.2us for URLLC
Slot length	eMBB: 0.5ms (14 symbols), 0.25ms (7 symbols) (Optional: mini-slots) for sub 6 GHz 0.125ms for above 6 GHz URLLC: 0.125ms
Number of Layers	1
BS antenna elements	Up to 256 Tx and Rx antenna elements (64 or 128 is recommended) for sub 6 GHz Up to 256 Tx and Rx antenna elements for above 6 GHz (around 30 GHz)
UE antenna elements	Up to 8 Tx and Rx antenna elements (4 is recommended) for sub 6 GHz Up to 32 Tx and Rx antenna elements for above 6 GHz (around 30 GHz)
User location and speed	80% Indoor (3km/h) and 20% outdoor (30km/h)
Traffic Type	Full buffer traffic or non-full-buffer traffic depends on the scenario
Inter Site Distance	500m

Table 2.2-3 :- Urban Macro Deployment Attributes

2.2.4 Rural

This section focuses on continuous and large coverage.

Scenario specific deployment attributes and expected values are listed in Table 2.2-4.

Attributes	Expected Values
Carrier Frequency	Sub 6 GHz (around 4GHz) and sub 1 GHz
Aggregated system bandwidth	100 MHz for sub 6 GHz 20 MHz for sub 1 GHz
Sub-carrier spacing	eMBB: 30 kHz for sub 6 GHz 120 kHz for above 6 GHz URLLC: 60(30) kHz
CP length	2.3us for eMBB 1.2us for URLLC
Slot length	eMBB: 0.5ms (14 symbols), 0.25ms (7 symbols) (Optional: mini-slots) for sub 6 GHz 0.125ms for above 6 GHz URLLC: 0.125ms
Number of Layers	1
BS antenna elements	Up to 256 Tx and Rx antenna elements (64 or 128 is recommended) for sub 6 GHz Up to 64 Tx and Rx antenna elements for below 1 GHz
UE antenna elements	Up to 8 Tx and Rx antenna elements (4 is recommended) for sub 6 GHz Up to 4 Tx and Rx antenna elements for sub 1 GHz
User location and speed	50% Indoor (3km/h) and 50% outdoor (30km/h to 120km/h)
Traffic Type	Full buffer traffic or non-full-buffer traffic depends on the scenario
Inter Site Distance	1500m to 5000m

Table 2.2-4 :- Rural Deployment Attributes

2.2.5 High speed

This section focuses on high reliability with continuous coverage along track in high speed trains. Scenario specific deployment attributes and expected values are listed in Table 2.2-55.

Attributes	Expected Values
Carrier Frequency	Sub 6 GHz and above 6 GHz (around 30 GHz)
Aggregated system bandwidth	100 MHz for sub 6 GHz 800 MHz for above 6 GHz (around 30 GHz)
Sub-carrier spacing	eMBB: 30 kHz for sub 6 GHz 120 kHz for above 6 GHz URLLC: 60(30) kHz
CP length	2.3us for eMBB 1.2us for URLLC
Slot length	eMBB: 0.5ms (14 symbols), 0.25ms (7 symbols) (Optional: mini-slots) for sub 6 GHz 0.125ms for above 6 GHz URLLC: 0.125ms
Number of Layers	1
BS antenna elements	Up to 256 Tx and Rx antenna elements (64 or 128 is recommended) for sub 6 GHz Up to 256 Tx and Rx antenna elements for above 6 GHz (around 30 GHz)
UE antenna elements	Up to 8 Tx and Rx antenna elements (4 is recommended) for sub 6 GHz Up to 32 Tx and Rx antenna elements for above 6 GHz (around 30 GHz)
User location and speed	100% in train Up to 500km/h
Traffic Type	Full buffer traffic or non-full-buffer traffic depends on the scenario
Inter Site Distance	500m to 1500m

Table 2.2-5 :- High Speed Deployment Attributes

2.3 UE test devices calibration

Once the network technology is mature, several network performance measurements can be carried out using commercial devices. This is due to the compliance to device categories that establish minimum performance requirements defined by the standards. These minimum limits provide the baseline for eliminating the device performance contribution from the measured network performance. Otherwise, in order to have an unbiased evaluation of the network performance, one needs to use a set of calibrated Test and Measurement tools. The tool calibration is performed in advance allowing the tool to properly measure only the network contribution. Such tools, nevertheless, do not provide a general measurement of the system performance, given their normally higher capabilities and much different form factors compared to UEs.

In the pre-commercial trials there will only be a few UE and BS types available, which also lack standard certification and testing. Furthermore, they will be of a heterogeneous nature, and it is expected that this will result in some bias, especially in the initial phase. They will be mostly un-optimized prototypes with potentially unstable nature.

The presence or absence of a screen on the device could also impact the type of measurements that can be performed. Since the goal of the initiative is to test the 5G network and not the UEs or BSs, there is the need to establish a calibration baseline that would allow us to determine what contribution is coming from the UE, the BS or the network. This is especially true when the UEs come in different form factors and from different vendors.

2.4 UE pre-trial testing

A pre-trial calibration procedure will be established for all the UEs and BSs involved in the trial initiative. For the UEs the calibration procedure should be performed in the lab, in order to provide an estimation of the baseline performance of each device. The test lab performing the calibration should be equipped with as many end-to-end components as possible and reproduce as close as possible the conditions that the device will encounter in the field. A testbed lab similar to the one considered in [3] is suggested for performing cable conducted tests. Several types of tests should be included in the procedure:

- **Sensitivity tests:** these tests are aimed to identify the sensitivity of the device at different received power levels, including different types of interference. Starting from ideal no noise conditions, including first AWGN and scanning different SNR/SINR, then including adjacent channel interference and sweeping again different SNR/SINR. These tests require already many iterations and sweeps, so a minimal number of KPIs should be considered, such as throughput and latency.
- **Ideal baseline:** all the tests and KPIs that will be evaluated in the field and tested in ideal conditions, with high SNR/SINR with no channel impairments, in order to have the maximum performance possible out of the device.
- **Realistic tests:** all the tests and KPIs that will be evaluated in the field and tested with a set of pre-defined scenarios [4] that represent realistic channel variations, including the behaviour that the network would have with handovers. These tests will allow the understanding of how the KPIs degrade in different complex and realistic scenarios.

On top of the established KPIs, in order to have a proper calibration a multi-domain device profiling should also be considered.

In addition to the throughput tests described above, the pre-trial UE tests will include a set parametric measurements performed by a test system aimed at providing confidence that the device would likely pass (or fail) conformance testing, if it was available. It is expected that the tests will include the following, but it will ultimately be determined by the availability at the start of each trial.

- Basic Rx sensitivity on the channels and bandwidths required.
- Basic throughput tests including data pass through.
- Transmit power and power control.
- Modulation error and frequency accuracy up to high order QAM.
- Spectrum emissions and spurious.
- Basic protocols and RRM to allow cell selection, link establishment using 5G NR NSA.

It is assumed that these tests will be performed over the air (OTA) but as these will be prototype devices it may be possible to perform conducted tests as well.

2.5 BS pre-trial testing

As with the UEs supplied for the trials, the base stations will also be based on pre-commercial models that will not have been formally conformance tested. They are also likely to be affected by transportation and installation, and therefore some form of confidence tests are required to ensure that they are still fit for purpose to ensure the NGMN trials will be valid and representative of real future 5G networks.

To this end it is proposed that a set of OTA installation tests created to verify the basic performance of a base station once it has been installed and then again periodically throughout the trials to maintain validity. The tests will be designed around elements of the conformance specification but with allowances being made for the additional uncertainties due to operating in the field rather than in a controlled test chamber. The actual tests performed will be based on the technology available at the start of each trial and is expected to include:

Static tests (BS in test mode)

- Maximum EIRP (in peak direction), direction error relative to boresight.
- Modulation accuracy in terms of EVM, SINR, RSRQ, RSRP, Frequency error.
- Output power control, max, range and linearity.
- Occupied bandwidth and ACLR.
- Approximate beam shape and direction error in horizontal plane (tower sites only).
- Rx sensitivity, REFSENS.

Dynamic tests (BS in Idle state)

- EIRP and quality of the primary synchronization signal (PSS) measured OTA.

3 Trial test requirements

The purpose of this section is to define the KPIs and executable proof points. Every test/KPI includes a detailed definition, considered scenarios, the target values and most importantly a clear testing methodology. The level of details should allow the tests to be reproducible by different parties which will then enable the benchmarking and comparison of the different trial efforts.

3.1 Latency

Latency is a very important parameter for enabling 5G use cases, particularly the URLLC use case for Latency-critical applications, such as, factory or home automation, automated vehicles, gaming services, remote computing...

This section aims at demonstrating that pre-commercial 5G solutions (infrastructure, transport and devices) are meeting the expected Latency performances through most significant testing configuration cases. Both control plane and user plane latencies are considered.

For completing the section 2.1.3 on “Trial Network Setup and IP Configuration”, it should be clearly stated in the Latency report, whether or not, IPsec gateways are part of the Trial Architecture.

3.1.1 Control plane latency

This test is to validate the state transitions (Idle, connected...) and the state transition times.

These tests are intended to validate different mobility state transitions (control plane) and their transitions times. More specifically, the tests aim to:

- Quantify “Idle to Connected”/ “Connected to Idle”, and “Inactive to Connected”/ “Connected to Inactive” state transition times.
- Verify the associated process for each type of state transition.

3.1.1.1 Definitions

References: UE States & State Transitions [5].

- Radio resource control (RRC) Idle state is characterized by:
 - Cell re-selection mobility;
 - [FFS: The UE AS context is not stored in any gNB or in the UE;]
 - Paging is initiated by the core network (CN); paging area is managed by CN.
- RRC_INACTIVE state is characterized by:
 - Cell re-selection mobility;
 - CN – NR radio access network (RAN) connection (both C/U-planes) has been established for UE;
 - The UE AS context is stored in at least one gNB and the UE;
 - Paging is initiated by NR RAN;
 - RAN-based notification area is managed by NR RAN;
 - NR RAN knows the RAN-based notification area which the UE belongs to;
- RRC_CONNECTED State is defined when:
 - The UE has an NR RRC connection;
 - The UE has an AS context in NR;
 - NR RAN knows the cell which the UE belongs to;
 - Transfer of unicast data to/from the UE;
 - Network controlled mobility, i.e. handover within NR and to/from E-UTRAN.

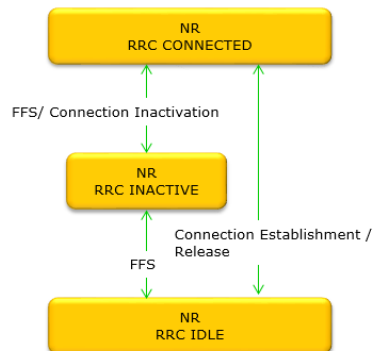

Figure 3.1.1-1 :- NR UE states and state transitions

3.1.1.2 Test environment

3.1.1.2.1 *Test setup*

A basic configuration will be defined in order to facilitate implementation of tests and comparison of results.

Both non-standalone (example Scenario 3x) and standalone architectures will be considered.

Number of users:

- Latency testing with a single user is the priority.
- A scenario with 10 users located under the same cell on average could be kept as optional.

Latency testing should be performed at several locations across the considered cell for ensuring different radio conditions.

Measurements should be performed in a loaded scenario. 70% network resource usage in all cells is recommended for the “Loaded scenario”. This could be achieved using dummy traffic generator.

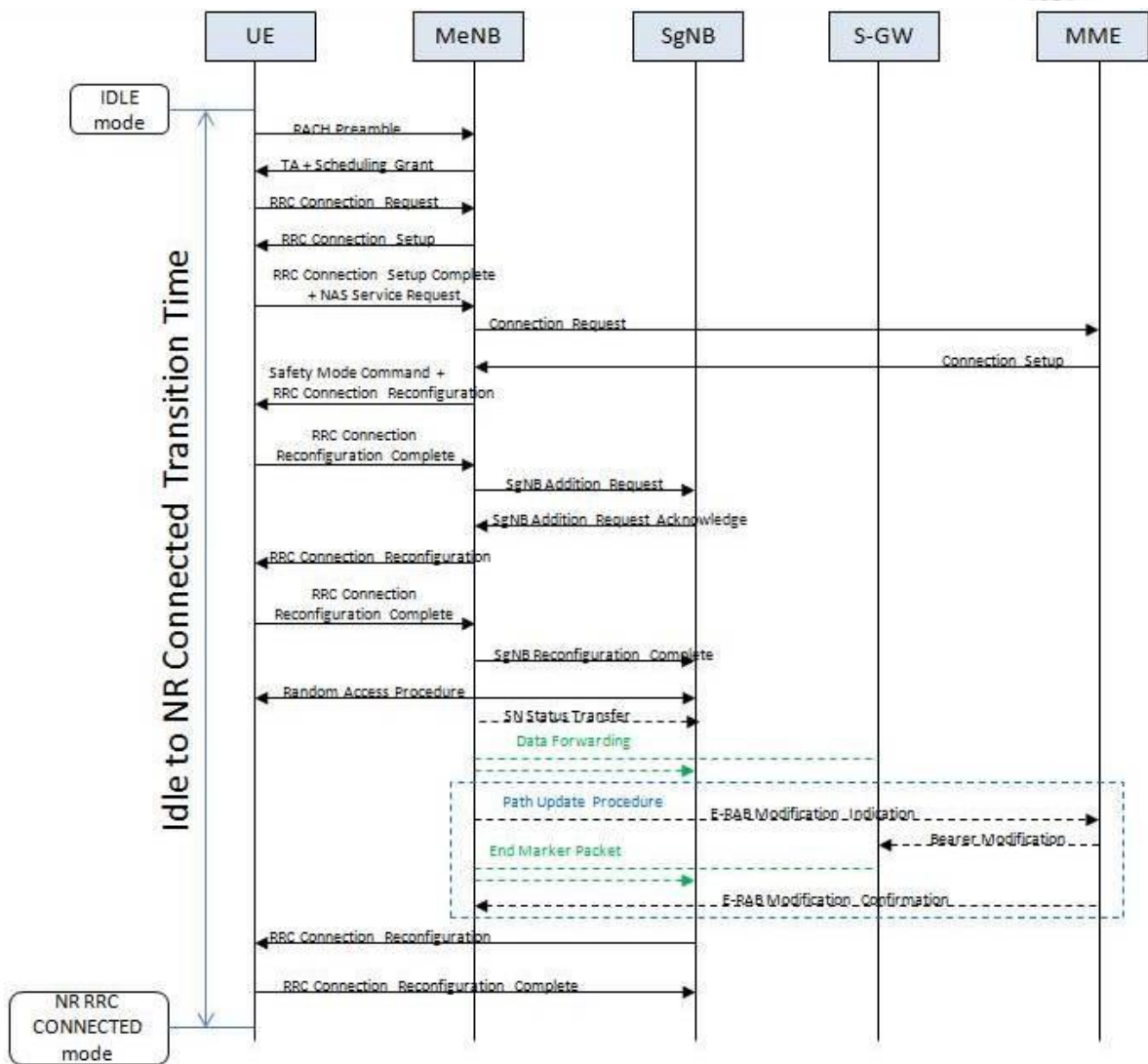

Figure 3.1.1-2 :- NR RRC Idle to NR Connected Message Flow in NSA Configuration⁵

⁵ Adapted from [6] and [7] in merging both LTE RRC signalling and gNB addition procedures.

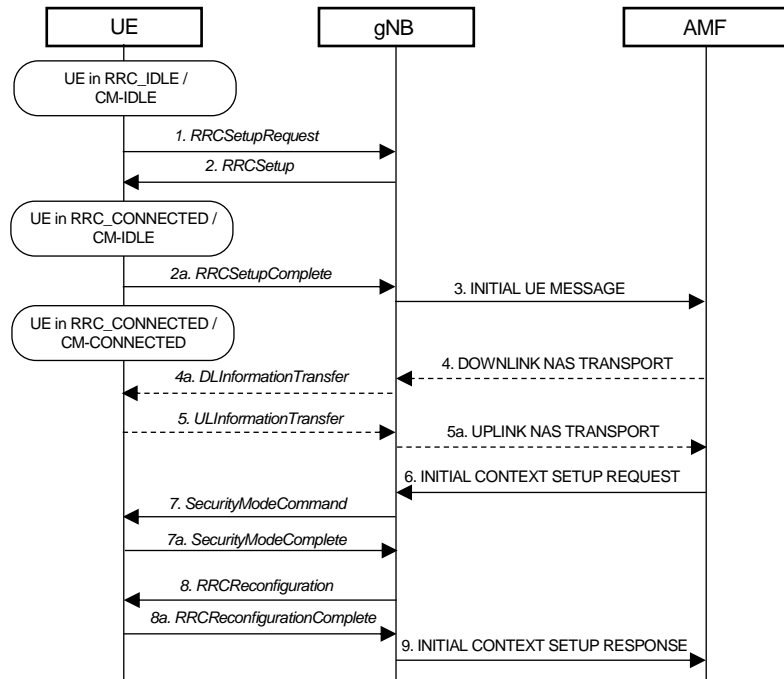

Fig. 3.1.1-3 **UE triggered** NR RRC Idle to NR RRC Connected transition message flow in SA configuration.
(Source: 3GPP TS 38.300 V15.3.1.)

For the NR RRC Inactive to NR RRC Connected transition time measurement in SA configuration, two cases shall be considered:

- UE triggered transition from NR RRC_INACTIVE to NR RRC_CONNECTED (see Fig. 3.1.1-4)
- Network triggered transition from NR RRC_INACTIVE to NR RRC_CONNECTED (see Fig. 3.1.1-5)

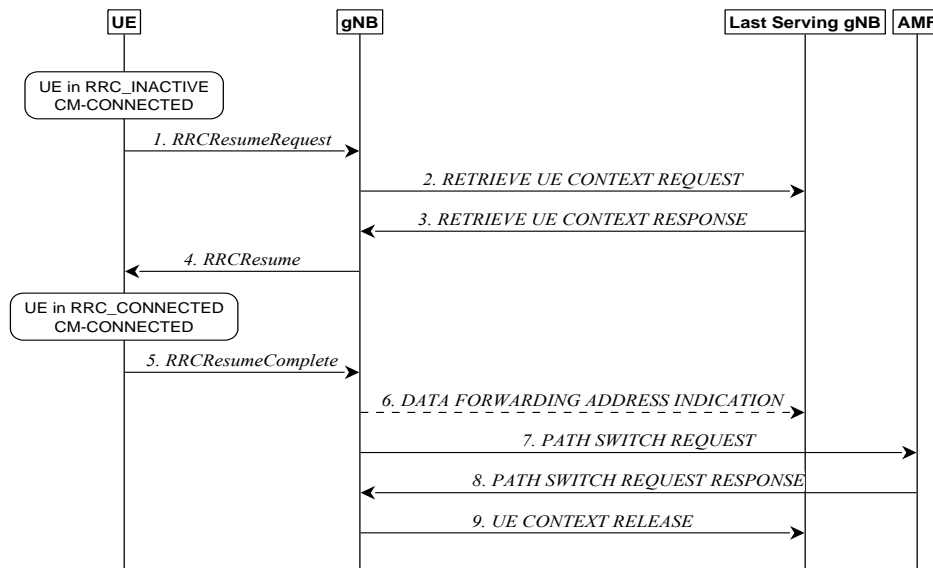

Fig. 3.1.1-4 UE triggered transition from NR RRC_INACTIVE to NR RRC_CONNECTED in SA configuration - UE context retrieval success. (Source: 3GPP TS 38.300 V15.3.1)

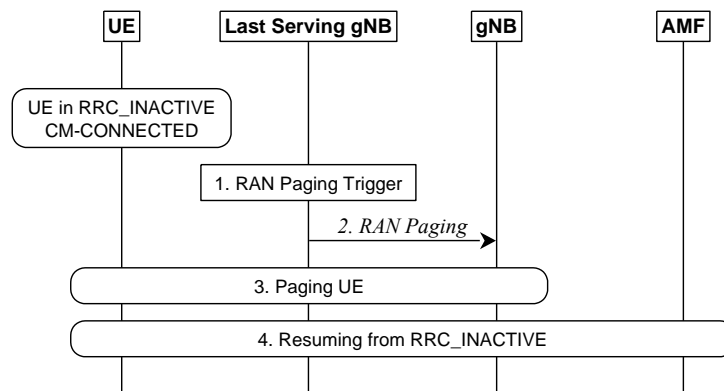

Fig. 3.1.1-5 Network triggered transition from RRC_INACTIVE to RRC_CONNECTED message flow in SA configuration. (Source: 3GPP TS 38.300 V15.3.1)

3.1.1.2.2 *Test procedure*

NR RRC Idle to NR RRC Connected latency in NSA configuration

1. In the serving cell, start UE trace and UE power cycle.
2. 4G Core Network initiates UE Context Release Command messages, and then UE transmits Idle state.
3. Ping a server on the 4G Core Network to trigger a service request from UE.
4. Stop UE trace.
5. Based on UE log, evaluate the transition time:
(Transition time at UE side = Time of last “RRC reconfiguration complete” – Time of “RACH preamble transmission”). Refer to figure 3.1.1-2 . When considering figure 3.1.1-2, system parameters should be set for immediate SgNB addition procedure.
6. Repeat steps 1-5 20 times.

NR RRC Idle to NR RRC Connected latency in SA configuration

1. In the serving cell, start UE trace and UE power cycle.
2. 5G Core Network initiates UE Context Release Command messages, and then UE transmits Idle state.
3. Ping a server on the 5G Core Network to trigger a service request from UE.
4. Stop UE trace.
5. Based on UE log, evaluate the transition time:
(Transition time at UE side = Time of last “RRC reconfiguration complete” – Time of “RRC Setup Request”). Refer to figure 3.1.1-3.
6. Repeat steps 1-5 20 times.

NR RRC Inactive to NR RRC Connected latency in SA configuration

UE Triggered Transition

1. In the serving cell, ensure UE is in Inactive State and moved from its last Serving g-NodeB to under the coverage of another g-NodeB (actual).
2. Start UE and g-NodeB traces.
3. Ping a server on the 5G Core Network to trigger a service request from UE.
4. Stop traces.
5. Based on UE and g-NodeB logs, evaluate the transition time:
(Transition time = “Path Switch Request Response” at g-NodeB – Time of “RRC Connection Resume Request” at UE side). Refer to figure 3.1.1-4.
6. Repeat steps 1-5 20 times.

Network Triggered Transition

1. In the serving cell, ensure UE is in Inactive State.
2. Start UE and g-NodeB traces.
3. Trigger a RAN paging event (e.g. in initiating an incoming DL user plane)
4. Observe that the UE switches to Connected mode.
5. Stop UE trace.
6. Based on UE and g-NodeB logs, evaluate the transition time:
(Transition time = Time of “Resuming from RRC Inactive” – “Paging UE Message”). Refer to figure 3.1.1-5.
7. Repeat steps 1-6 20 times.

3.1.1.3 **Success criteria**

The metric to validate the tests shall be the transition times between states. Trial initiatives shall report on used trigger points to evaluate the state transitions times. Minimum 20 valid samples are required for result evaluation. The result will be calculated and reported as an average from these 20 samples. Result evaluation:

- Minimum value, maximum value and average value measured in msec.

- Expected target value in SA configuration:
- NGMN recommendations = Idle <-> Connected transition time ≤ 10 ms [5]
- NGMN recommendations = Inactive <-> Connected transition time ≤ 10 ms (pending 3GPP definition).

3.1.1.4 Reporting and Analysing results

Tests results should be summarized in the following table:

State Transition Latency	Min	Max	Median
Idle to Active			
Inactive to Connected			

Table 3.1-1 :- Test results summary

3.1.2 User plane latency

3.1.2.1 Definition

When considering latency requirements, the following **important** metrics are considered:

- E2E Latency between UE and Application Server: Measures the duration between the transmission of a small data packet from the application layer at the source node and the successful reception at the application layer at the destination node plus the equivalent time needed to carry the response back.
- RAN Latency: Measures the time it takes to successfully deliver an application layer packet/message from the radio protocol layer 2/3 service data unit (SDU) ingress point to the radio protocol layer 2/3 SDU egress point via the radio interface in both uplink and downlink directions, where neither device nor base station reception is restricted by DRX [5].
- Core Latency: The round trip time between gNB and the Application Server.

However:

User plane latency between UE and Evolved Packet Core (EPC) or Next Generation Core network (NGC):

- Measures the time it takes to transfer a small data packet from user terminal to the Layer 2 / Layer 3 interface of the 5G system destination node, plus the equivalent time needed to carry the response back is seen as optional and could be consider for URLLC use case, for avoiding negative impact of delays outside the 5G system.

For the sake of clarity, in the rest of this Latency section, the purpose is to consider Round Trip Times (RTT) for both RAN and End to End Latencies.

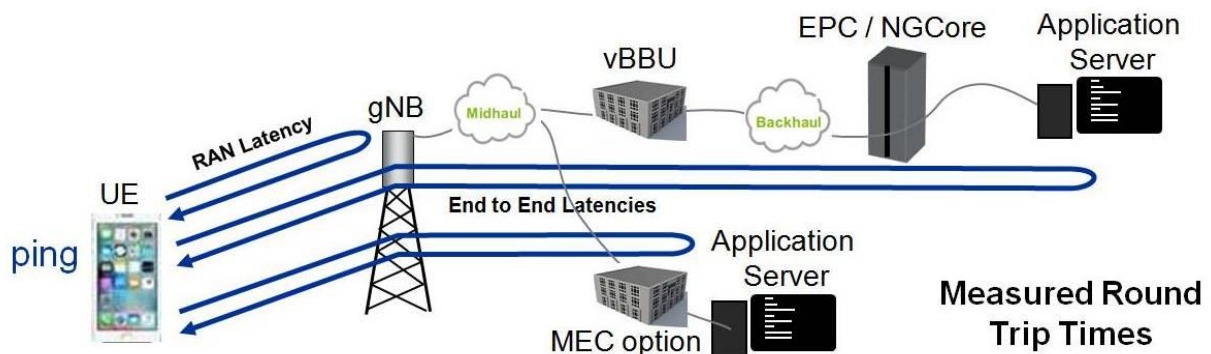

Figure 3.1.-3 :- Round Trip Latency for RAN and End to End

3.1.2.2 Test environment

3.1.2.2.1 Test setup

With the very short latency target by 5G, the transmission delay on the transport segment between the RAN and the core and finally the application server becomes more important relatively. 1ms delay in the fibre corresponds to 200 km transmission. Consequently, the type of network architecture and the location of this application server are fundamental in the test setup definition.

This is the reason why two scenarios are defined for both eMBB and URLLC:

- A first scenario with typical deployment of centralized core network and the server more than 200 km far from the end user.
- A second scenario with the core network user plane gateway (4G or 5G) and the server very close to the RAN. It is the case of data steering to a local data network, such as the site of an enterprise. It can also be the Multi-access Edge Computing (MEC) concept (Local Break Out to the application server).

Architectures for eMBB



Figure 3.1.2-4:- Case 1: Typical commercial deployment with 200km between 5G NB and NG core user plane

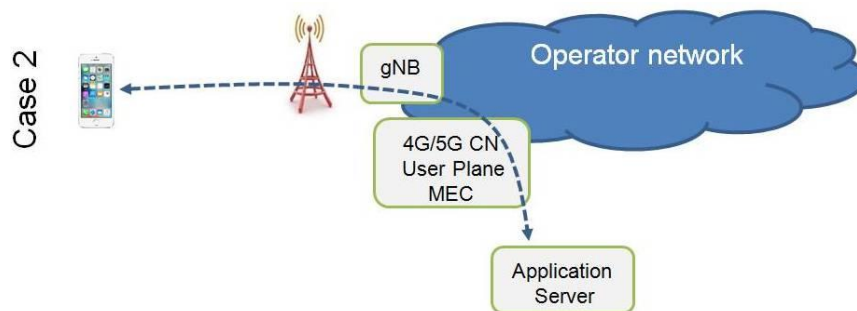

Figure 3.1.2-5:- Case 2: Mobile Edge Computing - data steering to local server to reduce the E2E latency

Architecture for URLLC

The URLLC scenarios will consider the implementation of a specific E2E slice, with the implementation of radio stacks to reduce the latency (to be standardized in 3GPP: shorter slot length, radio link control (RLC) mode, hybrid automatic repeat request (HARQ) management ...).

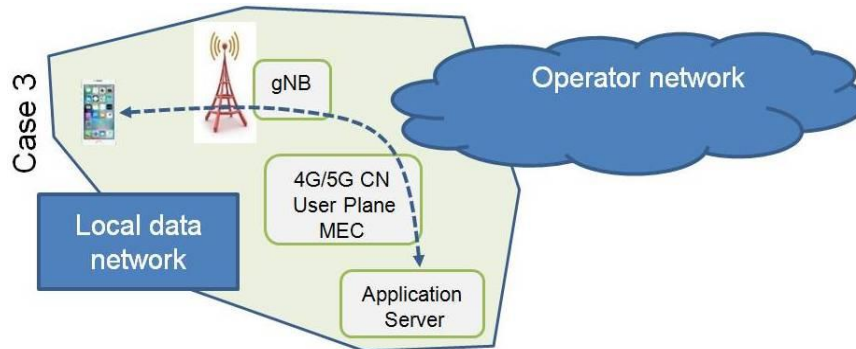

Figure 3.1.2-6:- Case 3: Data steering to Local Data network

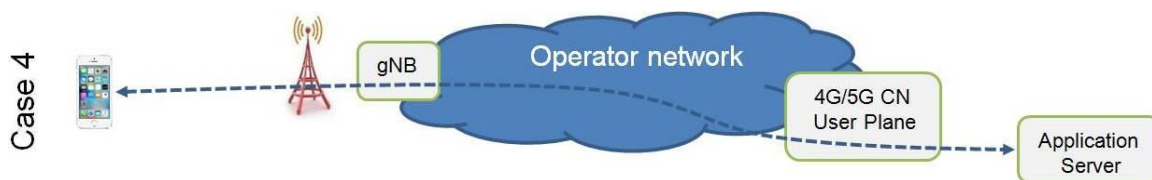

Figure 3.1-6:- Case 4

3.1.2.2.2 Test configuration

For both eMBB and URLLC scenarios the below tables provide the critical radio configuration settings to be used. They are extracted from the above section 2.2.3 – Urban Macro.

Attributes	Expected Values
Carrier Frequency	Sub 6 GHz and/or above 6 GHz (around 30 GHz)
Sub-carrier spacing	30 kHz for sub 6 GHz 120 kHz for above 6 GHz
CP length	2.3µs
Slot length	0.5ms (14 symbols), 0.25ms (7 symbols) (Optional: mini-slots) for sub 6 GHz 0.125ms for above 6 GHz
Number of Layers	1

Table 3.1-2:- Configuration for eMBB (Cases 1 & 2)

- System bandwidth (BW): No specific constraint but bandwidth value needs to be reported.
- FDD mode, or TDD mode with (75% / 25%) and/or (50% / 50%) typical DL/UL ratio.

Attributes	Expected Values
Carrier Frequency	Sub 6 GHz and/or above 6 GHz (around 30 GHz)
Sub-carrier spacing	60(30) kHz
CP length	1.2µs
Slot length	URLLC: 0.125ms
Number of Layers	1

Table 3.1-3:- Configuration for URLLC (Cases 3 & 4)

- System bandwidth (BW): no specific constraint but bandwidth value needs to be reported.

ngmn e. V.

Großer Hasenpfad 30 • 60598 Frankfurt • Germany

Phone +49 69/9 07 49 98-04 • Fax +49 69/9 07 49 98-41

- FDD mode, or TDD mode with (75% / 25%) and/or (50% / 50%) typical DL/UL ratio.

For both eMBB and URLLC scenarios, the scheduling modes should be reported.

3.1.2.2.3 *Logging at gNB side and UE side*

On the UE side, the following metrics should be available for performance assessment:

- RSRP (Reference Signal Received Power)
- RSRQ (Reference Signal Received Quality)
- RAN Latency (when possible)
- E2E (End to End) Latency
- Ping Success Rate
- Packet Loss Rate

At the gNB side:

- Latency from gNB to EPC/NGC

3.1.2.2.4 *Test Procedure*

1. Select sector pointing into the trial area.
2. Select a location in that cell (good, average and cell conditions) based on the cell grid:
 - Good conditions should be represented by $-90 \text{ dBm} < \text{RSRP}$
 - Average conditions should be represented by $-100 \text{ dBm} < \text{RSRP} < -90 \text{ dBm}$;
 - Cell edge conditions should be represented by $\text{RSRP} < -100 \text{ dBm}$
3. Start traces on protocol analyser
4. Measurement performed for both unloaded and loaded scenario.
70% network resource usage in all cells is recommended for the “Loaded scenario”. This may be achieved using dummy traffic generator.
5. Perform multiple (100) DL/UL standard size (32, 1500B) pings over the UE under test to a local test server, and record Max, Min and Average ping times.
6. Derive the RAN Latencies on 5 (chosen around the average End to End Latency) of these 100 measurements:
 - With the protocol analyser, capture the traffic over NG interface (in gNB) with high accuracy time stamping (decode the ping request/response from UE/PDN gateway over the appropriate GTP-U tunnel). This shall allow characterizing the round trip time between gNB and the Application Server, defined here as core Latency. We consider that the Application Server is located closely to the EPC/NGC node.
 - Calculate the DL/UL RAN Latency as the subtraction of the two previous values:
RAN Latency = End to End Latency - Core Latency.

Alternate procedures:

The advantage of Round Trip Times measurements is that they do not require accurate time sync between source/sink. However, they are at the mercy of the server and client response time (depends on application) which is not the aim of the measurement and may also introduce some measurement results uncertainties and fluctuation over time.

Considering doing one-way-measurements with packet tracking can solve this issue and can either replace or complement the RTT (more advanced and more accurate compared to RTT).

3.1.2.3 *Success criteria*

The 5G system should be able to provide 10 ms E2E latency in general and 1 ms E2E latency for the use cases which require extremely low latency. Note these latency targets assume the application layer processing time is negligible to the delay introduced by transport and switching.

The given objectives are referring to Round Trip Times (RTT) and are set for both RAN and End to End Latencies.

For eMBB use case:

ngmn e. V.

Großer Hasenpfad 30 • 60598 Frankfurt • Germany

Phone +49 69/9 07 49 98-04 • Fax +49 69/9 07 49 98-41

- RAN Latency ≤ 8 ms
- E2E Latency with 200 km distance between NR node and EPC/NGCore + Application server $\leq 10-15$ ms

For URLLC use case:

- RAN Latency ≤ 1 ms
- E2E Latency within Local Data Network ≤ 2 ms (Case 3)
- E2E Latency with Operator network ≤ 3 ms (Case 4)

Note: 3GPP is working on the concept of “self-contained sub-frames” that would permit to have UL and DL transmissions within the same TTI. This feature would permit to reduce the latency introduced by the UL/DL configurations in TDD.

3.1.2.4 Reporting and Analysing results

For each architecture case (refer to Case 1 to Case 4 here above) and for considered:

- Frequency bands (<6GHz, >6GHz),
- Duplexing modes (FDD, TDD) and TDD ratios minimum, maximum and average latencies shall be reported using the templates that follow.

Average latency values, over the measurement period, should be used for comparison with success criteria values.

Packet size [byte]	RF condition	RAN latency [ms]			EPC/NGC latency [ms]			E2E latency [ms]		
		Mean	Min.	Max.	Mean	Min.	Max.	Mean	Min.	Max.
32	Good									
	Average									
	Cell edge									
1500	Good									
	Average									
	Cell edge									

Table 3.1.2-4 :- Latency Results Summary

Packet size [byte]	RF condition	EPC/NGC ping success rate (%)	EPC/NGC packet loss rate (%)	E2E ping success rate (%)	E2E packet loss rate (%)
32	Good				
	Average				
	Cell edge				
1500	Good				
	Average				
	Cell edge				

Table 3.1.2-5 :- Success Rate Results Summary

3.2 User Throughput

This section describes the test specifications for user throughput including peak throughput, throughput at interference limited cell edge, cell edge coverage throughput and throughput in different interference/coverage conditions.

3.2.1 Peak throughput

5G is expected to provide significant improvement in the context of peak data rates (on both UL and DL). 5G data rate requirements are in the order of 100 Mbps to 1 Gbps for user experienced data rate, with peaks of 10 Gbps data rate. This leads to an improvement needed (compared to LTE Rel'12) to meet NGMN requirements in the order of > 10x.

The purpose of this test is to verify peak DL and UL UE data rate provided by 5G system.

3.2.1.1 Definition

Peak user throughput is the maximum DL/UL data rate achievable for a single user located at the best location within a cell.

3.2.1.2 Test environment

3.2.1.2.1 Test setup

Maximum achievable DL/UL data rate should be measured in the field environment. High-level test set-up is depicted in Figure 3.2-1 - Test setup for DL/UL peak rate below.

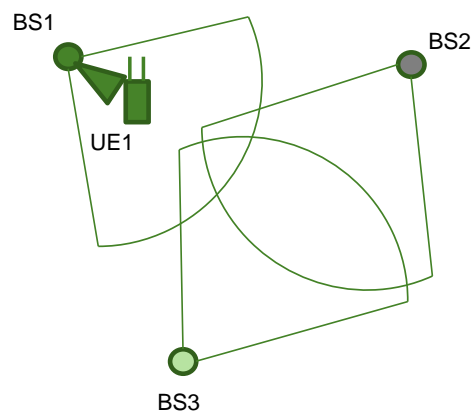

Figure 3.2-1 - Test setup for DL/UL peak rate

There should be only one UE in the cell under test, positioned in the ideal radio conditions. No other UEs should be placed in the surrounding cells. The test can be conducted in indoor or outdoor deployment scenario. Peak rate test should be executed in stationary scenario.

3.2.1.2.2 Test Configuration

There are two use cases considered for the 5G peak rate test: eMBB service and URLLC service. This leads to following configuration options:

- Conf. 1 (eMBB service):
 - Sub-carrier spacing:
 - 30 kHz for <6GHz deployment
 - 120kHz sub-carrier spacing for > 6GHz deployment
 - 2.3us CP length
 - Slot length:
 - 500us (14 symbols at 30kHz)
 - 125us (120kHz)
 - Deployment options: Urban Macro (< 6GHz) and Urban Pico (> 6GHz)

- System BW:
 - 100 MHz for eMBB < 6 GHz
 - 800 MHz for eMBB > 6GHz
- DL peak rate test: if dynamic UL/DL switching is not supported, minimum UL configuration
- UL peak rate test: if dynamic UL/DL switching is not supported, minimum DL configuration
- Conf. 2 (URLLC service):
 - 60(30) kHz sub-carrier spacing
 - 1.2us CP length
 - Slot length: 0.125ms
 - System BW: 100 MHz (< 6 GHz)
 - DL peak rate test: if dynamic UL/DL switching is not supported, minimum UL configuration
 - UL peak rate test: if dynamic UL/DL switching is not supported, minimum DL configuration

3.2.1.2.3 *Test procedure*

The following test procedure define the peak UL/DL data rate test:

1. Coverage of the test area defined as Received RSRP > -60 dBm and SINR > 22dB as measured with measurement tool.
2. Identify a location(s) where combination of highest MIMO rank, modulation and coding rate can be attained with stability.
3. Ensure that there are no UEs connected in any of the surrounding cells.
4. Repeat steps 5-6 at each location with the UE static in that location.
5. Connect 1 UE to the sector and ensure there is only this UE connected to the sector.
6. Measure L1 and PDCP layer throughput
 - a. If dynamic UL/DL ratio is not supported, reconfigure the system for minimum UL DL/UL ratio
 - b. Download to the UE using UDP or TCP (using iperf) for DL peak test
 - c. Measure PDCP layer throughput (PDCP throughput is payload bits divided by the aggregated time) and L1 throughput using measurement tool; session duration should be at least 2 minutes; max./min./avg. value should be reported

If dynamic UL/DL ratio is not supported, reconfigure the system for minimum DL DL/UL ratio

- d. Upload to the test server using UDP or TCP (using iperf) for UL peak test
- e. Measure PDCP layer throughput (PDCP throughput is payload bits divided by the aggregated time) and L1 throughput using measurement tool; session duration should be at least 2 minutes; max./min./avg. value should be reported.

3.2.1.2.4 *Logging at gNB side and UE side*

On UE side, the following metrics should be available for performance assessment:

- DL throughput (L1 and PDCP throughput)
- UL throughput (L1 and PDCP throughput)
- RSRP (Reference Signal Received Power)
- RSRQ (Reference Signal Received Quality)
- SINR
- DL BLER (at first retransmission)
- MIMO mode used (incl. MIMO rank)

3.2.1.3 *Success criteria*

Wide range coverage (eMBB use case); < 6GHz, 100 MHz BW

- NGMN: 5G should provide 10x improvement on average and peak rates per user (eMBB use case).

- Assuming practical LTE Rel'12 systems, 600 Mb/s (Cat. 11/12) peak data rate on DL is defined, 5G should deliver 6 Gbps peak rate.
- Assuming practical LTE Rel'12 systems, 150 Mb/s (Cat. 11/12) peak data rate on UL is defined, 5G should deliver 1.5 Gbps peak rate.
- Theoretical peak rate derived from the peak spectral efficiency requirement [5]:
3Gbps/1.5Gbps for DL/UL
Above values are calculated assuming 8x8 DL MIMO for single UE. For 4x4 DL MIMO, 5G should deliver around 1.75 Gbps DL peak rate with DDDSU slot configuration.
For UL assuming 2x2 UL MIMO, 5G should deliver around 200 Mbps UL peak rate with DDDSU slot configuration.

Local coverage (eMBB use case); > 6GHz, 800 MHz BW

- 5G data rate requirements are in the order of multiple Gbps data rate for DL (> 20 Gbps).
- 5G peak UL data rate requirement of > 10 Gbps is required.

Expected output is comparison of measured peak throughput with NGMN and 3GPP targets.

3.2.2 Throughput at interference limited cell edge

Purpose of this test is to verify user experience in the interference limited scenarios under worst case conditions.

3.2.2.1 Definition

Interference limited cell edge throughput is defined as DL/UL UE throughput in the cell overlap area under a high network load conditions.

3.2.2.2 Test environment

3.2.2.2.1 Test setup

Interference limited cell edge DL/UL data rate should be measured in the field environment. High-level test set-up is described in Figure 3.2.2-2 - Test setup for DL/UL interference limited throughput; below. In general, there are two architectural deployment options:

1. centralized (Figure 3.2.2-2a) and
2. distributed (Figure 3.2.2-2b).

Note that only 3 cells are shown, but in practice additional surrounding cells should be deployed. It is recommended that at least 5 gNBs are deployed.

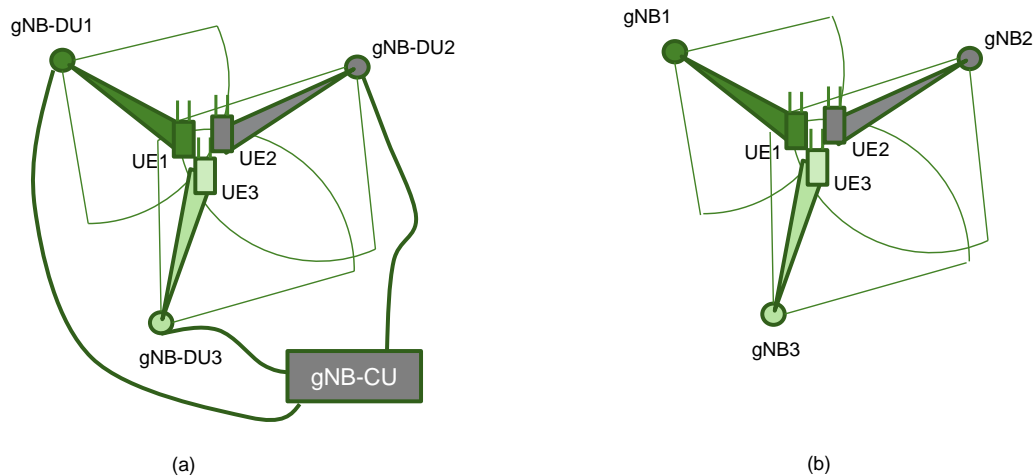

**Figure 3.2.2-2 - Test setup for DL/UL interference limited throughput;
(a) centralized deployment, (b) distributed deployment**

Centralized deployment option should benefit from joint processing capability and resource coordination features.

There should be cluster of cells active in the test set-up. Number of surrounding cells should be as high as possible. There should be one UE in the cell under test, the UE should be located in the cell overlap area. Surrounding, overlapping cells should be transmitting with a strongest beam towards the measured UE. Remaining surrounding cells should be transmitting with a random beam. The test can be conducted in the outdoor or indoor deployment scenario. It is stationary test.

3.2.2.2.2 Test Configuration

There are two use cases considered for the interference limited cell edge data rate test: eMBB service and URLLC service. This leads to following configuration options⁶:

- Conf. 1 (eMBB service):
 - Sub-carrier spacing:
 - 30 kHz for <6GHz deployment
 - 120kHz sub-carrier spacing for > 6GHz deployment
 - 2.3us CP length
 - Slot length:
 - 500us (14 symbols at 30kHz)
 - 125us (120kHz)
 - Deployment options: Urban Macro (< 6GHz) and Urban Pico (> 6GHz)
 - System BW:
 - 100 MHz for eMBB < 6 GHz
 - 800 MHz for eMBB > 6GHz
 - DL throughput test: DL/UL ratio: if dynamic UL/DL switching is not supported, minimum UL configuration
 - UL throughput test: DL/UL ratio: if dynamic UL/DL switching is not supported, minimum DL configuration

- Conf. 2 (URLLC service):
 - 60 (30) kHz sub-carrier spacing
 - 1.2us CP length

⁶ These configurations apply to most of the deployment scenarios is section 2.2.

- Slot length: 0.125ms
 - System BW: 100 MHz (< 6 GHz)
- DL throughput test: DL/UL ratio: if dynamic UL/DL switching is not supported, minimum UL configuration
- UL throughput test: DL/UL ratio: if dynamic UL/DL switching is not supported, minimum DL configuration

3.2.2.2.3 Test procedure

Following test procedure defines the interference limited UL/DL data rate test:

1. Select sector pointing into the trial area
2. Select cell edge location in the cell under test.
 - a. RSRQ (xx to yy).⁷
 - b. In the overlap of *two* neighbor cells
3. Load overlapping cells with UEs such that the strongest beam of the neighbor cells is transmitting in the direction of UE under test.
4. Load all other surrounding cells
5. Repeat steps 6-7 at each location with the UE static in that location.
6. Connect UEs to the sector and ensure there is only this UE connected to the sector.
7. Start data transmission to/from all UEs in the system
 - a. Download to all UEs using UDP or TCP (using iperf) for DL test
 - b. Upload to the test server using from all UEs UDP or TCP (using iperf) for UL test
8. Measure PDCP layer throughput (PDCP throughput is payload bits divided by the aggregated time) and L1 throughput using measurement tool; session duration should be at least 2 minutes; max./min./avg. value should be reported.

3.2.2.2.4 Logging at gNB side and UE side

On UE side, the following metrics should be available for performance assessment:

- DL throughput (L1 and PDCP throughput)
- UL throughput (L1 and PDCP throughput)
- RSRP (Reference Signal Received Power)
- RSRQ (Reference Signal Received Quality)
- SINR
- DL BLER (at first retransmission)
- MIMO mode used
- UE & gNB Tx power
- Channel utilization or scheduling/activity factor

3.2.2.3 Success criteria

Wide range coverage (eMBB use case); < 6GHz, 100 MHz BW; dense-urban environment

- NGMN: 100X improvement for UL/DL data rate on cell edge (assuming centralized architecture) (NGMN white paper 6: 50 Mbps and 25 Mbps).
- 3GPP [5]: 3x IMT-A (meaning: 0.18 bits/s/Hz or 18Mbps on DL and 0.09 bits/s/Hz or 9Mbps on UL)
- ITU-R [8]: The minimum requirements for average spectral efficiency for various test environments are:
 - 0.225 bits/s/Hz DL cell edge spectral efficiency is assumed, 5G should deliver 22.5 Mbps cell edge data rate.

⁷ These values depend on the deployment scenario. The used values in the trial should be reported.

- 0.15 bits/s/Hz UL cell edge spectral efficiency is assumed, 5G should deliver 15 Mbps cell edge data rate.

Wide range coverage (eMBB use case); < 6GHz, 100 MHz BW; rural environment

- ITU-R: The minimum requirements for average spectral efficiency for various test environments are:
 - 0.12 bits/s/Hz DL cell edge spectral efficiency is assumed, 5G should deliver 12 Mbps cell edge data rate.
 - 0.045 bits/s/Hz UL cell edge spectral efficiency is assumed, 5G should deliver 4.5 Mbps cell edge data rate.

Local coverage (eMBB use case); > 6GHz, 400 MHz BW; indoor hotspot

- ITU-R: The minimum requirements for average spectral efficiency for various test environments are:
 - 0.3 bits/s/Hz DL cell edge spectral efficiency is assumed, 5G should deliver 120 Mbps cell edge data rate.
 - 0.21 bits/s/Hz UL cell edge spectral efficiency is assumed, 5G should deliver 84 Mbps cell edge data rate.

3.2.3 Cell edge coverage throughput

Purpose of this test is to verify user experience in the coverage limited cell edge scenario.

3.2.3.1 Definition

Coverage limited cell edge scenario is defined as location at the cell edge with 1-3 dB lower path loss compared to control channel coverage limit (path loss limit).

3.2.3.2 Test environment

3.2.3.2.1 Test setup

Coverage limited cell edge DL/UL data rate should be measured in the field environment. High-level test set-up is given on Figure 3.2.3-3 - Test setup for DL/UL coverage limited throughput below.

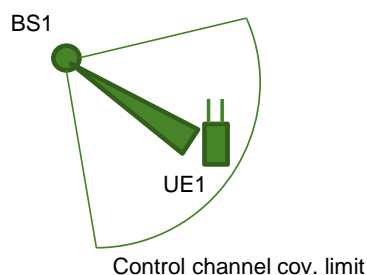

Figure 3.2.3-3 - Test setup for DL/UL coverage limited throughput

The overall set-up should be only one UE in the cell under test, positioned in the coverage limited cell edge location. No other UEs should be placed in the surrounding cells. The UE should be placed in different positions with respect to expected beam forming gain:

- a. Within beam-grid in LOS (open area).
- b. In NLOS (reflective area)

Test should be executed in stationary scenario.

3.2.3.2.2 Test Configuration

There are two use cases considered for the 5G peak rate test: eMBB service and URLLC service. This leads to following configuration options:

- Conf. 1 (eMBB service):
 - Sub-carrier spacing:
 - 30 kHz for <6GHz deployment
 - 120kHz sub-carrier spacing for > 6GHz deployment
 - 2.3us CP length
 - Slot length:
 - 500us (14 symbols at 30kHz)
 - 125us (120kHz)
 - Deployment options: Urban Macro (< 6GHz) and Urban Pico (> 6GHz)
 - System BW:
 - 100 MHz for eMBB < 6 GHz
 - 800 MHz for eMBB > 6GHz
 - DL throughput test: DL/UL ratio: if dynamic UL/DL switching is not supported, minimum UL configuration
 - UL throughput test: DL/UL ratio: if dynamic UL/DL switching is not supported, minimum DL configuration

- Conf. 2 (URLLC service):
 - 60 (30) kHz sub-carrier spacing
 - 1.2us CP length
 - TTI length: 0.125ms
 - System BW: 100 MHz (< 6 GHz)
 - DL throughput test: DL/UL ratio: if dynamic UL/DL switching is not supported, minimum UL configuration
 - UL throughput test: DL/UL ratio: if dynamic UL/DL switching is not supported, minimum DL configuration

3.2.3.2.3 **Test procedure**

Following test procedure describes the cell edge UL/DL data rate test:

1. Select sector pointing out of the trial area
2. Identify coverage limited location: it is defined as Received RSRP = XX dBm ($XX = \text{Minimum RSRP level where Call Set Up Success rate is greater or equal to } X\% \text{ (\# of attempts is ffs)}$) Ensure that there are no UEs connected in any of the surrounding cells.
3. Repeat steps 4-6 at each location with the UE static in that location.
4. Connect one UE to the sector and ensure there is only this UE connected to the sector.
5. Perform
 - a. Download to the UE using UDP or TCP (using iperf) for DL peak test
 - b. Upload to the test server using UDP or TCP (using iperf) for UL peak test
6. Measure PDCP layer throughput (PDCP throughput is payload bits divided by the aggregated time) and L1 throughput using measurement tool; session duration should be at least 2 minutes; max./min./avg. value should be reported.

3.2.3.2.4 **Logging at gNB side and UE side**

On UE side, the following metrics should be available for performance assessment:

- DL throughput (L1 and PDCP throughput)
- UL throughput (L1 and PDCP throughput)
- RSRP (Reference Signal Received Power)

- RSRQ (Reference Signal Received Quality)
- SINR
- DL BLER (at first retransmission)
- MIMO mode used

3.2.3.3 Success criteria

Wide range coverage (eMBB use case); < 6GHz, 100 MHz BW; dense-urban environment

- NGMN: 100X improvement for UL/DL data rate on cell edge (assuming centralized architecture)
- 3GPP: 3x IMT-A (meaning: 0.18 bits/s/Hz or 18Mbps on DL and 0.09 bits/s/Hz or 9Mbps on UL)
- ITU-R: The minimum requirements for average spectral efficiency for various test environments are:
 - 0.225 bits/s/Hz DL cell edge spectral efficiency is assumed, 5G should deliver 22.5 Mbps cell edge data rate.
 - 0.15 bits/s/Hz UL cell edge spectral efficiency is assumed, 5G should deliver 15 Mbps cell edge data rate.

Wide range coverage (eMBB use case); < 6GHz, 100 MHz BW; rural environment

- ITU-R: The minimum requirements for average spectral efficiency for various test environments are:
 - 0.12 bits/s/Hz DL cell edge spectral efficiency is assumed, 5G should deliver 12 Mbps cell edge data rate.
 - 0.045 bits/s/Hz UL cell edge spectral efficiency is assumed, 5G should deliver 4.5 Mbps cell edge data rate.

Local coverage (eMBB use case); > 6GHz, 400 MHz BW; indoor hotspot

- ITU-R: The minimum requirements for average spectral efficiency for various test environments are:
 - 0.3 bits/s/Hz DL cell edge spectral efficiency is assumed, 5G should deliver 120 Mbps cell edge data rate.
 - 0.21 bits/s/Hz UL cell edge spectral efficiency is assumed, 5G should deliver 84 Mbps cell edge data rate.

3.2.4 Throughput in different coverage conditions (link budget test)

The objective of this test is to measure the throughput for various path-losses in isolated cell, for both uplink and downlink for system coverage assessment.

3.2.4.1 Definition

The path-loss in the downlink will be computed as follows:

$$Pathloss = P_{TxRS} - RSRP \quad (3.2.1)$$

It is assumed that path-loss is equivalent in uplink and we will use the same value in both UL and DL. Path-loss at a given location could be the averaged value over a short period (e.g. 20s).

3.2.4.2 Test environment

3.2.4.2.1 Test setup

DL/UL link budget test should be measured in the field environment. High-level test set-up is given in Figure 3.2.4-44 below.

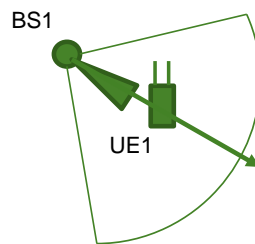

Figure 3.2.4-4 - UL/DL link budget test

The overall setup will be only a single UE in the cell under test, moving in the boresight angle out from the cell until coverage is lost. Both, measurement in static locations along the test route or a slow drive test can be performed.

3.2.4.2.2 Test Configuration

There are two use cases considered for the 5G link budget test: eMBB service and URLLC service. This leads to following configuration options:

- Conf. 1 (eMBB service):
 - Sub-carrier spacing:
 - 30 kHz for <6GHz deployment
 - 120kHz sub-carrier spacing for > 6GHz deployment
 - 2.3us CP length
 - Slot length:
 - 500us (14 symbols at 30kHz)
 - 125us (120kHz)
 - Deployment options: Urban Macro (< 6GHz) and Urban Pico (> 6GHz)
 - System BW:
 - 100 MHz for eMBB < 6 GHz
 - 800 MHz for eMBB > 6GHz
 - DL throughput test: DL/UL ratio: if dynamic UL/DL switching is not supported, minimum UL configuration
 - UL throughput test: DL/UL ratio: if dynamic UL/DL switching is not supported, minimum DL configuration
- Conf. 2 (URLLC service):
 - 60(30) kHz sub-carrier spacing
 - 1.2us CP length
 - Slot length: 0.125ms
 - System BW: 100 MHz (< 6 GHz)
 - DL throughput test: DL/UL ratio: if dynamic UL/DL switching is not supported, minimum UL configuration
 - UL throughput test: DL/UL ratio: if dynamic UL/DL switching is not supported, minimum DL configuration

3.2.4.2.3 Test procedure

Following test procedure describes the peak UL/DL data rate test:

1. Select sector pointing out from the trial area.
2. Select location in that cell to be close to gNB, where the highest transport block size and MIMO rank can be achieved.
3. Ensure that there are no UEs connected in any of the surrounding cells (or lock all neighbor cells).
4. Connect UE to the cell and

- a. For a drive test: drive in the boresight angle out from the serving cell until the call is dropped (speed \approx 30 kmph).
 - b. For stationary tests: select at least 20 measurement points on the drive in the boresight angle out from the serving cell (evenly distributed) until the call cannot be established.
5. Measure PDCP layer throughput (PDCP throughput is payload bits divided by the aggregated time) and L1 throughput using measurement tool; session duration should be at least 2 minutes; max./min./avg. value should be reported
 6. Repeat 1-5.

3.2.4.2.4 **Logging at gNB side and UE side**

On UE side, the following metrics should be available for performance assessment:

- DL throughput (L1 and PDCP throughput)
- UL throughput (L1 and PDCP throughput)
- RSRP (Reference Signal Received Power)
- RSRQ (Reference Signal Received Quality)
- SINR
- DL BLER (at first retransmission)
- MIMO mode used

3.2.4.3 **Success criteria**

The measured UL/DL throughput values should be presented in a graph vs signal strength.

3.2.5 **Throughput in different interference conditions (Average User Throughput)**

The target of this test is measure the Average User Throughput in the network.

3.2.5.1 **Definition**

Average user experience is defined as the average of the throughputs measured in various positions within the cell (in case of stationary measurements) or the average of the throughputs measured during a drive test.

3.2.5.2 **Test environment**

3.2.5.2.1 **Test setup**

High-level test set-up is given on Figure 3.2.5-5 - Test setup for DL/UL throughput in different interference conditions; (a) centralized deployment, (b) distributed deployment below. In general, there are two architectural deployment options: centralized (Figure 3.2.5-5a) and distributed (Figure 3.2.5-5b). Note that only three cells are shown, but in practice additional surrounding cells should be deployed. It is recommended that at least 10 gNBs are deployed.

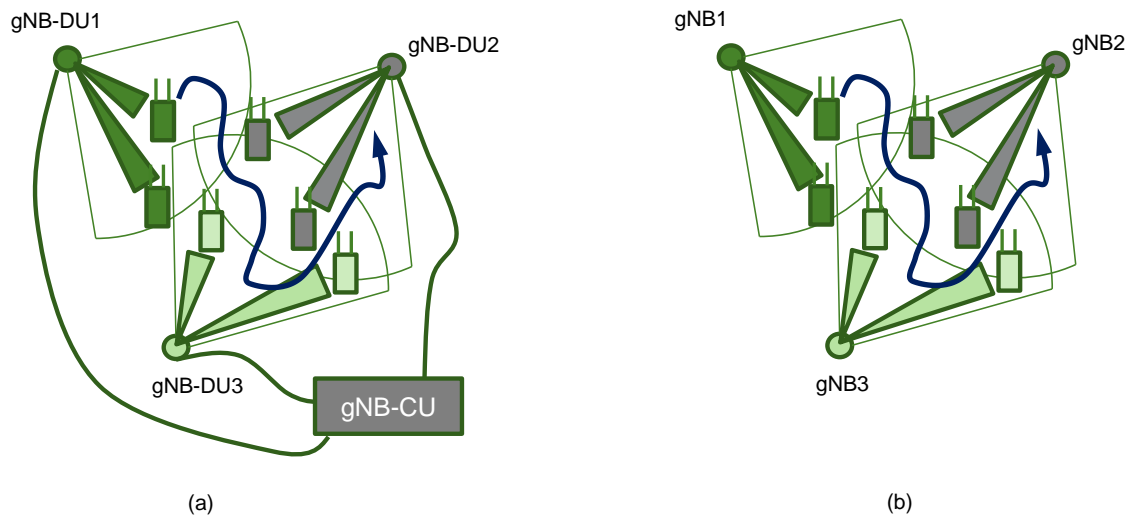

Figure 3.2.5-5 - Test setup for DL/UL throughput in different interference conditions; (a) centralized deployment, (b) distributed deployment

Centralized deployment option should benefit from joint processing capability and resource coordination features. There should be a cluster of cells active in the test set-up. Number of surrounding cells should be as high as possible. There should be one UE under test. Static locations and/or drive route should be identified to cover the whole range of SINR. The drive route should cover different environments such as open areas, close to reflecting buildings, LOS and NLOS. Additionally, different relevant inter-cell relations depending on used beam management features, such as direction in extension of neighbor cell BS to UE direction. There should be at least X static UEs in all cells (evenly distributed in the cell/coverage area). Several loading load scenarios should be considered: no load, full load.

3.2.5.2.2 Test Configuration

There are two use cases considered for the 5G average UE throughput test: eMBB service and URLLC service. This leads to following configuration options:

- Conf. 1 (eMBB service):
 - Sub-carrier spacing:
 - 30 kHz for <6GHz deployment
 - 120kHz sub-carrier spacing for > 6GHz deployment
 - 2.3us CP length
 - Slot length:
 - 500us (14 symbols at 30kHz)
 - 125us (120kHz)
 - Deployment options: Urban Macro (< 6GHz) and Urban Pico (> 6GHz)
 - System BW:
 - 100 MHz for eMBB < 6 GHz
 - 800 MHz for eMBB > 6GHz
 - DL throughput test: DL/UL ratio: if dynamic UL/DL switching is not supported, minimum UL configuration
 - UL throughput test: DL/UL ratio: if dynamic UL/DL switching is not supported, minimum DL configuration.

- Conf. 2 (URLLC service):
 - 60 (30) kHz sub-carrier spacing
 - 1.2us CP length

- TTI length: 0.125ms
 - System BW: 100 MHz (< 6 GHz)
- DL throughput test: DL/UL ratio: if dynamic UL/DL switching is not supported, minimum UL configuration
- UL throughput test: DL/UL ratio: if dynamic UL/DL switching is not supported, minimum DL configuration.

3.2.5.2.3 Test procedure

Following test procedure defines the UE average UL/DL data rate test:

1. Select cells pointing to the trial area and providing continuous coverage.
2. Select drive route and/or static locations to cover the whole range of SINR
 - a. Cell edge should represent interference limited positions with SINR < 0dB.
 - b. Average conditions should be represented by SINR (5dB to 10dB).
 - c. Good conditions should be represented by SINR (15dB to 20dB)
 - d. Excellent conditions should be represented by SINR > 22dB
3. Load surrounding cells by deploying the loading UEs or by activating load feature.
4. Connect UE to the cell and perform download/upload to/from the UE using UDP or TCP (using iperf).
5. Measure PDCP layer throughput (PDCP throughput is payload bits divided by the aggregated time) and L1 throughput using measurement tool; session duration should be at least 2 minutes; max./min./avg. value should be reported.

3.2.5.2.4 Logging at gNB side and UE side

On UE side, the following metrics should be available for performance assessment:

- DL throughput (L1 and PDCP throughput)
- UL throughput (L1 and PDCP throughput)
- RSRP (Reference Signal Received Power)
- RSRQ (Reference Signal Received Quality)
- SINR
- DL BLER (at first retransmission)
- MIMO mode used

3.2.5.3 Success criteria

The drive test results could be presented as a curve of throughput versus SINR. The bandwidth and the UL/DL ratio for TDD need to be reported along with the results. Calculate the average data rate for each static measurement points.

Wide range coverage (eMBB use case); < 6GHz, 100 MHz BW; dense-urban environment

- NGMN: 5G should provide 10x improvement on average and peak rates per user (eMBB use case).
 - Assuming practical LTE Rel'12 systems, 2.6 bits/s/Hz (Cat. 11/12) average DL spectral efficiency is assumed, 5G should deliver 260 Mbps average data rate.
 - Assuming practical LTE Rel'12 systems, 2.0 bits/s/Hz (Cat. 11/12) average UL spectral efficiency is defined, 5G should deliver 200 Mbps average data rate.
- ITU-R: The minimum requirements for average spectral efficiency for various test environments are:
 - 7.8 bits/s/Hz DL average spectral efficiency is assumed, 5G should deliver 780 Mbps average data rate.
 - 5.4 bits/s/Hz UL average spectral efficiency is assumed, 5G should deliver 540 Mbps average data rate.

Wide range coverage (eMBB use case); < 6GHz, 100 MHz BW; rural environment

- ITU-R: The minimum requirements for average spectral efficiency for various test environments are:
 - 3.3 bits/s/Hz DL average spectral efficiency is assumed, 5G should deliver 330 Mbps average data rate.
 - 1.6 bits/s/Hz UL average spectral efficiency is assumed, 5G should deliver 160 Mbps average data rate.

Local coverage (eMBB use case); > 6GHz, 800 MHz BW; indoor hotspot

- ITU-R: The minimum requirements for average spectral efficiency for various test environments are:



- 9.0 bits/s/Hz DL average spectral efficiency is assumed, 5G should deliver 7.2 Gbps average data rate.
- 6.75 bits/s/Hz UL average spectral efficiency is assumed, 5G should deliver 5.4 Gbps average data rate.

Wide range coverage (URLLC use case); < 6GHz

- ITU-R: The minimum requirements for average spectral efficiency for various test environments are:
 - 3.3 bits/s/Hz DL average spectral efficiency is assumed, 5G should deliver 330 Mbps average data rate.
 - 1.6 bits/s/Hz UL average spectral efficiency is assumed, 5G should deliver 160 Mbps average data rate.

3.3 Cell capacity

Cell capacity is a critical KPI to evaluate the aggregate capacity of multi users served by a cell. The test is mainly for multi-user scenarios such as dense urban, urban macro and possibly rural. In this test, at least 10 UEs are suggested to put in different locations to represent different propagation environment for reflecting the MU MIMO beam forming transmission ability of BS.

The cell peak throughput and average throughput should be considered as the typical test case. For the test condition, both single cell and multi-cell should be considered to reflect the cell capacity in different inter-cell interference. The results of cell capacity can be interpreted as spectrum efficiency (see section 3.4) for comparison of different test systems. Besides, the system parameters can influence the results significantly such as bandwidth, frame structure, output power, so the system parameters of the test BS should be given for test results comparison.

Configured Parameter	Parameter Value
Frequency Band	
BS bandwidth	
BS output power	
Duplex Mode	
Frame structure (DL/UL Ratio)	
MIMO rank capability	

Table 3.3-1-1 :- BS System Parameters

3.3.1 Cell peak throughput

The cell peak throughput represents the maximum transmission ability for a certain cell. In this test, all UEs should be placed in good locations, where the RS-SINR of all the UEs is good. Additionally, the UEs should be separated in location enabling maximum MU-MIMO capacity, such as separation in angle-of-arrival utilizing different beams for each UE. For this test case, as it is used to reflect the maximum capacity ability, the test condition should be configured as the single cell without inter-cell interference.

3.3.1.1 Definition

The cell peak capacity is defined as the aggregate throughputs when all of the UEs are placed in good location with high SINR. According to the link direction, the uplink and downlink cell peak capacity should be defined. Besides, the test condition is configured as single cell.

3.3.1.2 Test Environment

3.3.1.2.1 Test setup

- **BS configuration:** configure the test cell BS system parameters depending on the deployment scenario, such as the frame structure, bandwidth, duplex mode, output power etc.
- **Network configuration:** Single cell without inter-cell interference and the other cells around the test cell should be configured no power output.
- **Test points:** 10 test points with high RS-SINR in the test cell and at least one UE should be placed in one test point.
- **Test devices:** at least 10 UE devices.

3.3.1.2.2 Test configuration

ngmn e. V.

Großer Hasenpfad 30 • 60598 Frankfurt • Germany

Phone +49 69/9 07 49 98-04 • Fax +49 69/9 07 49 98-41

Similar configurations to section 3.2.1.2.2 should be considered.

3.3.1.2.3 Test Procedure

1. Setup the test environment as the test configuration.
2. Downlink Cell Capacity Test
All of UEs are configured to receive downlink full-buffer UDP services. The downlink L3 PDCP throughput should be recorded as the indicator of the downlink cell capacity. The L3 PDCP throughput is data received in the receiver PDCP layer per second. The time for test is at least 5 minutes until the L3 throughput is stable. The stable throughput should be record as the final throughput in each test point.
3. Uplink Cell Capacity Test.
All of UEs are configured to transmit uplink full-buffer UDP services. The L3 PDCP throughput is data received in the receiver PDCP layer per second. The time for test is at least 5 minutes until the L3 throughput is stable. The stable throughput should be record as the final throughput in each test point.

3.3.1.3 Success criteria

Some related test data should be record, including: RSRP, RS-SINR, PDCP throughput, MCS, layer numbers of transmission data, UE uplink power, transmission mode etc.

The test results should be record for both downlink and uplink. The table below gives an example for downlink test result s record:

	L3 Throughput	RSRP	RS-SINR	MIMO Mode	Layer Num	MCS	RB Num	BLER
Test Point 1								
Test Point 2								
Test Point 3								
Test Point 4								
Test Point 5								
Test Point 6								
Test Point 7								
Test Point 8								
Test Point 9								
Test Point 10								

Table 3.3-2:- Downlink Test Results Record for Peak Cell Capacity

Based on the test results, the cell peak capacity can be obtained by aggregating the throughput of all the UEs. Besides, for the test results comparison, the recalculated cell peak capacity should be given based on the 100% corresponding link (100% downlink or 100% uplink) frame structure. The detailed formulas are described as follows:

$$\text{Throughput} = \sum \text{test point_TP} \quad (\text{both for DL and UL}) \quad (3.3-1)$$

$$\text{DL_Recalculate_TP} = \frac{\text{DL_Throughput}}{\text{DL_percentage}} \quad (3.3-2)$$

$$\text{UL_Recalculate_TP} = \frac{\text{UL_Throughput}}{\text{UL_percentage}} \quad (3.3-3)$$

	Test Results		Recalculated Results	
	Throughput (bps)	Spectrum Efficiency(bps/Hz)	Throughput (bps)	Spectrum Efficiency(bps/Hz)

Uplink				
Downlink				

Table 3.3-3 :- Cell Peak Capacity Results

3.3.2 Cell average throughput

The cell average throughput represents the average transmission ability for a certain cell. For this test case, the UEs (at least 10) in the test cell should be placed in different locations with different levels of RS-SINR to represent different transmission condition such as cell center, cell edge placement.

According to the level of RS-SINR, the transmission condition could be divided into four types: excellent, good, medium and bad. As the difference of test cells or test conditions may have great influence on the cell average SINR level, the definition of four types of test conditions is based on the cell RS-SINR statistics. The detailed definition method is described as below:

The average capacity test should consider both UL and DL interference. For example, we can define the neighboring cells to have 50% (or x%) DL traffic interference on the cell-under-test and the UL IoT increase for 5dB (or y dB). Under the test condition, the cell RS-SINR should be tested in all of the possible locations in the cell. Based on the test results, the RS-SINR distribution statistics could be calculated and described as a cumulative distribution function (CDF) curve.

For the convenience of testing, it is recommended to use the DL SINR CDF to find suitable locations for UEs, and since the excellent/good/medium/bad corresponds to a range of SINR values, the UL-SINR should not be too different distribution-wise.

According to CDF curve, the four types of transmission condition could be defined as: excellent (95%~100%), good (80%~90%), medium (40%~60%) and bad (5%~15%). These values could be a reference: excellent (>22dB), good (15~20dB), medium (5dB~10dB), bad (-5dB~0dB).

3.3.2.1 Definition

The cell average throughput is the aggregated throughput of all of UEs located with different transmission condition. The ratio of UEs with different types of transmission condition is excellent: good: medium: bad=1:2:4:3. For the test, both single cell and network cell condition should be considered.

It is worth noting that the UE locations should remain unchanged for single-cell and network-cell configuration tests, so that direct comparison is possible for understanding inter-cell interference impact on performance.

3.3.2.2 Test Environment

3.3.2.2.1 Test setup

3.3.2.2.1.1 Single Cell Test Configuration

Setup the test environment as the test condition as follows:

- **BS configuration:** configure the test cell BS system parameters depending on the deployment scenario, such as the frame structure, bandwidth, duplex mode, output power etc.
- **Network configuration:** Single cell without inter-cell interference and the other cells around the test cell should be configured no power output.
- **Test points:** chose 10 test points in the cell and the ratio of transmission condition is excellent: good: medium: bad=1:2:4:3. At least one UE should be placed in one test point.
- **Test devices:** at least 10 5G UE devices

3.3.2.2.1.2 Network cell Test Configuration

Setup the test environment as the test condition as follows:

- **BS configuration:** configure the test cell BS system parameters depending on the deployment scenario, such as the frame structure, bandwidth, duplex mode, output power etc.
- **Network configuration:** network cell configuration. The surrounding cells of the test cell should be configured as:
 - Downlink:* 50% interference level from neighbor cell both for control channel and data channel. The definition of 50% interference level is that 50% downlink transmission PRB are randomly chosen to transmit interference signal.
 - Uplink:* lead to 5dB uplink Interference over Thermal (IoT) rise for test cell. The definition of 5dB IoT rise is that the received interference noise from the UEs of neighbor cell uplink transmission should lead to 5dB rise of the receivers' noise power
- **Test points:** chose 10 test points in the cell and the ratio of transmission condition is excellent: good: medium: bad=1:2:4:3. At least one UE should be placed in one test point.
- **Test devices:** at least 10 5G UE devices.

3.3.2.2.2 Test configuration

Similar configurations to section 3.2.1.2.2 should be considered.

3.3.2.2.3 Test Procedure

1. Setup the test environment as the test configuration respectively for single cell configuration and Network cell test configuration
2. Downlink Cell Capacity Test
All of UEs are configured to receive downlink full-buffer UDP services. The downlink L3 PDCP throughput should be recorded as the indicator of the downlink cell capacity. The L3 PDCP throughput is data received in the receiver PDCP layer per second. The time for test is at least 5 minutes until the L3 throughput is stable. The stable throughput should be record as the final throughput in each test point.
3. Uplink Cell Capacity Test
All of UEs are configured to transmit uplink full-buffer UDP services. The uplink L3 PDCP throughput should be recorded as the indicator of the uplink cell capacity. The L3 PDCP throughput is data received in the receiver PDCP layer per second. The time for test is at least 5 minutes until the L3 throughput is stable. The stable throughput should be record as the final throughput in each test point.

3.3.2.3 Success criteria

Some related test data should be recorded, including: RSRP, RS-SINR, PDCP throughput, MCS, SINR, transmission data layer numbers, UE uplink power, transmission mode etc.

The test results should be record for both downlink and uplink. The table below gives an example for downlink test result s record:

	L3 Throughput	RSRP	RS- SINR	MIMO Mode	Layer Num	MCS	RB Num	BLER
Excellent Point 1								
Good Point 1								
Good Point 2								
Medium Point 1								
Medium Point 2								
Medium Point 3								
Medium Point 4								
Bad Point 1								
Bad Point 2								
Bad Point 3								

Table 3.3-4-4 :- Downlink Test Results Record for 50% Interference Level

Based on the test results, the cell average throughput could be obtained by aggregating the throughput of all of the UEs. Besides, for the test results comparison, the recalculated cell average throughput should be given based on the 100% corresponding link (100% downlink or 100% uplink) frame structure.

The detailed formulas are described as follows:

$$\text{Throughput} = \sum \text{excellent_TP} + \sum \text{Good_TP} + \sum \text{Medium_TP} + \sum \text{Bad_TP} \text{ (both for DL and UL)} \quad (3.3-4)$$

$$\text{DL_Recalculate_TP} = \frac{\text{DL_Throughput}}{\text{DL_percentage}} \quad (3.3-5)$$

$$\text{UL_Recalculate_TP} = \frac{\text{UL_Throughput}}{\text{UL_percentage}} \quad (3.3-6)$$

	Test Results		Recalculated Results		Interference Level
	Throughput (bps)	Spectrum Efficiency(bps/Hz)	Throughput (bps)	Spectrum Efficiency(bps/Hz)	
Uplink					
Downlink					

Table 3.3-5 :- Cell Average Throughput Results

3.4 Spectral efficiency

Spectral efficiency is a very important metric in the performance evaluation of 5G. The test case definition of spectral efficiency is identical to that of the user throughput and cell capacity as defined in sections 3.2 and 3.3 respectively. Since the user throughput and cell capacity test cases have been defined we will only refer to the previous test cases in this section to avoid duplication.

In this section the user throughput is referred to for the user spectral efficiency, however, the same can be applied for cell spectral efficiency by referring to the cell capacity section.

3.4.1 Definition

User spectral efficiency can be defined as below equation

- **Efficiency** = data rate per UE at given condition / BW that UE used for corresponding data speed

In order to harmonize with previous test result, we reconsider the test results in section 3.2 as shown below

- **Peak spectral efficiency:** Derived from peak throughput test result which is specified in section 3.2.1
- **Medium spectral efficiency:** Derived from cell average throughput which is specified in section 3.2.5. We only consider throughput test result in medium RF points which are specified in 3.2.5.2.
- **Cell edge spectral efficiency:** Derived from cell edge coverage throughput that is specified in section 3.2.3. In addition, we can use test result in section 3.2.2 in order to verify the edge UE spectral efficient in interference limited scenario.

3.4.2 Test environment

For the spectral efficiency, we reuse the test setups that are described in section 3.2.

- **Peak spectral efficiency:** consider setup that is described in 3.2.1.2
- **Medium spectral efficiency:** consider setup that is described in 3.2.5.2
- **Cell edge spectral efficiency:** consider setup that is described in 3.2.3.2 and 3.2.2.2

3.4.3 Success criteria

The spectral efficiency success criteria should be derived from the values provided in the sections 3.2 and 3.3.

Three spectral efficiency value are given below in this section based on the success criteria in section 3.2.

3GPP peak spectral efficiency targets (eMBB use case): 30 Bit/s/Hz for DL, 15 Bit/s/Hz for UL

ITU-R medium spectral efficiency targets (eMBB use case): 7.8 Bit/s/Hz for DL, 5.4 Bit/s/Hz for UL

ITU-R cell edge spectral efficiency targets (eMBB use case): 0.225 Bit/s/Hz for DL, 0.15 Bit/s/Hz for UL

Note: These values should also be compared to the NGMN targets (given in section 3.2)

In addition, in case of having some configuration changes, the results should be provided together with the changes.

3.5 Coverage

In telecommunications, the coverage area is the geographic area where the base station and the user device can communicate. Coverage depends on several factors, such as the environment (mountains, etc.) and buildings, technology, radio frequency and most importantly for two-way telecommunications the sensitivity and transmit efficiency including maximum output power of the base station and the end user device.

Coverage measurements usually comprise two aspects:

1. The availability, i.e. signal strength above a defined minimum threshold, of those downlink signal components (e.g. broadcast channels, synchronization signals or reference symbols) in a geographical area, which are required to allow the end user device to synchronize with the base station and to obtain basic network information.
2. The achieved service quality, e.g. a minimum data rate in case of mobile data services or a minimum speech quality in case of voice services, in a geographical area, which is required or defined.

Aspect 2 requires a communication link established between the base station and the end user device and in the general case an interface into the end user device and base station, which allows to extract either measured or achieved parameters like signal strength or data rate. Additionally, aspect 1 can be measured using so-called network scanners, i.e. passive measurement devices, which do not require an active communication link between the network scanner and the base station. Scanners do provide reference data for the measurements performed by the end user device.

As an example the SINR measurement done in the end user device is a crucial measurement, since it will be the basis for CQI reporting to the network and eventually determines the achievable throughput in case of a data service.

Likewise, RSRP and RSRQ are important measurements based on known reference symbols, which are performed in the end user device and reported to the network. Scanner equipment provide the same measurements based on known signals like broadcast channel, synchronization signals and reference symbols without affecting network operation. Although optional, it is highly recommended during trials and initial network installation phase to use scanner measurements in addition to end user device measurements/data.

Since end user devices may be in prototype or pre-commercial stage, scanner data will serve as an independent source of measurement results. Furthermore, scanner generally provides better sensitivity and results that are more accurate.

There are several main objectives to be satisfied by coverage test cases:

1. **Coverage gap analysis between 4G and 5G:** Depending on the 5G frequency bands and the legacy 4G frequency bands, there may exist a coverage gap even under the same propagation environment. It is important to understand this gap in diversified scenarios such as Urban Macro, Dense Urban, Urban roads, Rural, etc.
2. **Beamforming capability:** beamforming will be enabled in 5G BS with the help of active antenna systems, and both the data and the control signals will be pre-coded to boost signal quality. The beamforming benefits should be measured at cell edge.
3. **DL Data/control channel coverage difference:** the physical signals on the data channel will have different beamforming gain to that of the control channel. It is essential to identify the mismatch of coverage range if any between data and control channels, to ensure correct decoding at the UE. Also, there are different DL control channel boosting schemes to help the situation, e.g. dynamic beamforming or repeated transmission using a wide-beam.
4. **UL coverage enhancement at UE:** besides the power control mechanism, UE can have multiple antennas, and thus transmit diversity capability to aid UL coverage performance, e.g., UE Tx power is 23dBm without Tx diversity, or 26dBm with Tx diversity. There is also discussion on shared/supplementary UL feature in 3GPP, where LTE frequencies will be used for NR UL data and/or control and NR frequencies still for DL. Since during the trials, the UL and DL are inseparable, better UL coverage will lead to better DL performance.
5. **UL coverage enhancement using Supplementary UL :** In light of the UL coverage problem (at 3.5GHz or nearby frequency bands), 3GPP has proposed the SUL deployment option, where the UL and DL are decoupled and UL can use lower frequency band than the DL (e.g. sub1GHz or 1.8GHz) to enhance coverage. SUL will make the system

design of 5G more complicated, i.e. the base station and the user terminal needs to handle multi-frequency operation, albeit this is in SA scenario. If NSA standards are finalized in 2018, and SUL may imply that UL with LTE and DL with NR, the system design and UE requirement will increase again, for instance, seamless interworking between LTE and NR, therefore the testing procedure described below may need updating.

It is also worth noting that inter-cell interference is known as the bottleneck of coverage performance in 4G TDD networks. The level of interference is controlled by the neighboring cells' traffic load on the UL and/or the DL in the trials, on data and/or control channels, otherwise it will be difficult to accurately quantify the interference imposed on the cell-under-test. The following sections will be dividing the trials into outdoor single-cell coverage, outdoor multi-cell continuous coverage, outdoor to indoor coverage and indoor coverage respectively.

3.5.1 Outdoor Single-cell Coverage

3.5.1.1 Definition

The coverage performance will be tested in UL and DL, in control and data channels, in terms of both the maximum distances in LOS and NLOS conditions, and the corresponding data rates at cell edge. The benefits of various coverage enhancing features (e.g. Tx diversity) at gNB or UE should also be investigated. Coverage in this section is based on a mobile broadband data service, therefore the success criteria is an achieved data rate in a geographical area.

3.5.1.2 Test environment

3.5.1.2.1 Test setup

This test case will have one cell under test in a minimum of a 7-cell deployment environment (see figure below). Dense urban, urban macro and rural deployments scenarios are considered according to section 3.2. Frequency reuse factor is 1. BS and UE configuration tables to be added, e.g., Tx power, bandwidth, SU, SCS, N_FFT, frame structure, etc.

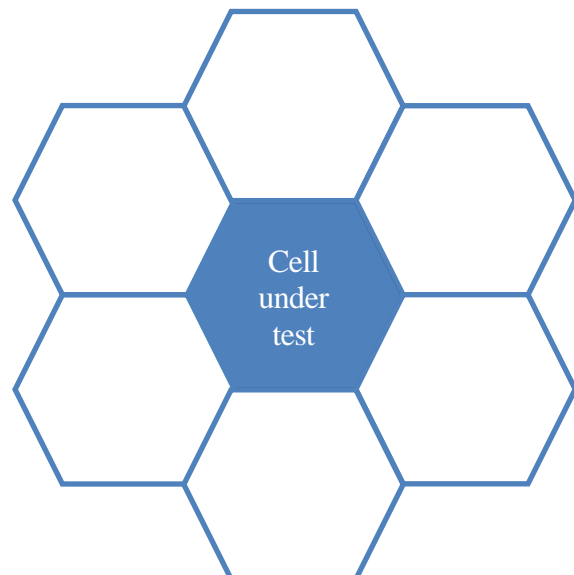

Figure 3.5-1 :- 7-Cell Deployment Environment

3.5.1.2.2 **Test configurations**

3.5.1.2.2.1 **Stand-alone cell**

This configuration focuses on the possible coverage difference between 4G and 5G BS.

Neighboring 4G and 5G cells are turned off, leaving the center 5G cell on. Note that, it is preferred that the 4G and 5G base stations are deployed at the same site to allow for direct comparisons. Additionally, prior to the trials, the noise floor of the 4G band (e.g. BW=20MHz) and 5G band (e.g. BW=100MHz) should be measured and recorded with the 5G base stations turned off and on respectively.

3.5.1.2.2.2 **Interference on control channel only**

This configuration focuses on the interference from neighboring cells on the control channel only, by turning on the 6 cells (broadcasting channel and synchronization channel are on) without any users or traffic, i.e. no interference on the data channel. Tests should be carried out on UL and DL separately.

3.5.1.2.2.3 **Interference on control and data channel**

This configuration focuses on the interference from neighboring cells on both the control and data channels, to create interference across the operating bandwidth. The level of the interference can be controlled by the allowed traffic in neighbor cells. Tests should be carried out on UL and DL separately.

Downlink: 50% interference level from neighbor cell both for control channel and data channel. The definition of 50% interference level is that 50% downlink transmission PRB are randomly chosen to transmit interference signal.

Uplink: lead to Y dB uplink Interference over Thermal (IoT) rise for test cell. The definition of YdB IoT rise is that the received interference noise from the UEs of neighbor cell uplink transmission should lead to Y dB rise of the receivers' noise power.

3.5.1.2.2.4 **SUL testing**

We are focusing on different band options to use for the UL in NR, e.g. 900MHz+3.5GHz and 1.8GHz+3.5GHz. This test case only differ from normal uplink coverage test (single cell, normal direction) by:

- turn off SUL function, carry out test procedures as normal
- turn on SUL function (e.g. turn on 900MHz 5MHz bandwidth NR cell or 1.8GHz 10MHz bandwidth NR cell in the test area, along with 3.5GHz 100MHz bandwidth NR cell;), repeat the test procedures, and record the difference

Note that this test case is only suitable for outdoor scenarios and outdoor-to-indoor scenario.

3.5.1.2.3 **Test procedures**

1. Activate cell under test
2. Activate surrounding cells
3. Configure cells according to test configuration (stand alone, interference on control channel only, interference on control and data channel, SUL testing)
4. Place end user devices in the cell under test and establish data connections.
 - a. Optionally place scanner at same end user device location
5. Move end user devices throughout the cell area and log data according to section 3.5.1.2.4
 - a. Optionally move scanner with end user device and log data according to section 3.5.1.2.5

3.5.1.2.4 **Logging at gNB and UE side**

ngmn e. V.

Großer Hasenpfad 30 • 60598 Frankfurt • Germany

Phone +49 69/9 07 49 98-04 • Fax +49 69/9 07 49 98-41

- For the coverage performance of the control channel and the data channel in DL and UL respectively, various channels' maximum path losses and coverage distances could be recorded, e.g. PDSCH, PUSCH, PDCCH, PUCCH. By comparing the coverage differences among channels, the limiting channel and its data rate at the coverage edge should be measured.
- Vice versa, the coverage distances that correspond to the following low data rates should be investigated;
UL: 512kbps, 1Mbps;
DL, 1Mbps, 2Mbps.
Note that these values are used for LTE testing and can be a baseline/reference for measurement.
- The control channel coverage should be measured and compared among different schemes (depends on the progress in Rel. 15):
 - PDCCH: choose a baseline transmission scheme, and two or more optional schemes for comparison:
 1. Single wide beam (LTE like)
 2. Single wide beam with repeated transmission
 3. Narrow beam sweeping (the number of beams should be configurable)
 Repeat with DL interference from neighbor cells
 - PUCCH
 1. Baseline: long duration single-slot transmission
 2. Compare to Long duration multi-slot transmission
 Repeat with UL interference from neighbor cells
 Repeat with UL enhancement, i.e. UE transmit diversity
 - PBCH and synchronization channel
 1. Cell search (SSS and PSS) and successful PBCH demodulation
 2. Compare different transmission schemes listed in the PDCCH tests
 Repeat with UL/DL interference from neighbor cells separately.

Parameters defined below will be measured and recorded during the drive / walk test. Additionally, location information is stored. In consequence, the measured parameters can be plotted for a certain geographical area and thus a realistic coverage map is generated.

	RSRP	RSRQ	RS-SINR	GPS location	Distance to BS	Throughput	LOS/NLOS
PDSCH							
PUSCH							

Table 3.5-1:- Parameters for DL/UL data channels

	RSRP	RSRQ	RS-SINR	GPS location	Distance to BS	BLER	LOS/NLOS
PDCCH							
PUCCH							

Table 3.5-2:- Parameters for DL/UL Control Channels

In cases where it is not possible to measure data/control channel signal strength & quality (e.g. PDSCH RSRP/RSRQ), for DL coverage, it is also practical to measure DL Throughput vs. SSB RSRP and/or CSI-RS RSRP. Similarly, for uplink coverage, UL Throughput vs. SSB RSRP should be measured. Besides, SSB RSRP where call drop occurs shall be reported.

	DL Throughput	SSB RSRP	SSB RSRQ	SSB SINR	GPS Location	Distance to BS	LOS/NLOS
Downlink							

Table 3.5-3:- Parameters for SSB Based DL Coverage

	DL Throughput	CSI-RS RSRP	CSI-RS RSRQ	CSI-RS SINR	GPS Location	Distance to BS	LOS/NLOS
Downlink							

Table 3.5-4:- Parameters for CSI-RS Based DL Coverage

	UL Throughput	SSB RSRP	SSB RSRQ	SSB SINR	GPS Location	Distance to BS	LOS/NLOS
Uplink							

Table 3.5-5:- Parameters for SSB Based UL Coverage

3.5.1.2.5 *Optional logging at scanner*

The reference measurements provided by the scanner should comprise the following parameters

	Signal power	SINR	GPS location	Distance to BS
PBCH				
PSS				
SSS				
	RSRP	SINR	GPS location	Distance to BS
CSI-RS				

Table 3.5-6 :- Scanner logged parameters

3.5.1.3 **Success criteria**

The coverage area achieving the data rates specified in section 3.5.1.2.4 should be recorded and compared to LTE coverage for the same frequency band or accounting for the coverage difference in the case of different frequency bands for 5G NR and LTE.

3.5.2 **Outdoor Multi-Cell Continuous Coverage**

3.5.2.1 **Definition**

This test case focuses on the continuous connectivity across multiple cells, hence it will provide guidance on deployment parameters such as inter-site distance, RSRP, RSRQ, RSSI and SINR. It is also important to consider the impact of traffic load and interference on coverage. Since when the traffic load increases, the noise floor of the BS and the mobile will increase and their sensitivity will decrease, leading to shrinking coverage area. Additionally, SUL functional performance needs to be test, and the difference in single-user and multi-user coverage test should be measured and analyzed.

3.5.2.2 **Test environment**

3.5.2.2.1 *Test setup*

Refer to Section 3.5.1.2.1.

3.5.2.2.2 *Test configurations*

ngmn e. V.

Großer Hasenpfad 30 • 60598 Frankfurt • Germany

Phone +49 69/9 07 49 98-04 • Fax +49 69/9 07 49 98-41

3.5.2.2.2.1 Interference on control channel only

Refer to Section 3.5.1.2.1.2

3.5.2.2.2.2 Interference on control and data channel

Refer to Section 3.5.1.2.1.3

3.5.2.2.2.3 SUL testing (single-UE)

Refer to Section 3.5.1.2.2.4, single NR user terminal

3.5.2.2.2.4 SUL testing (Multiple UE)

Refer to Section 3.5.1.2.2.4, multiple NR user terminals, for instance 10, and placed them at locations that satisfy the criteria of excellent/good/mid/bad =1:2:4:3, record the average cell capacity and relevant measurement data.

3.5.2.2.3 Test procedures

1. Activate cell under test
2. Activate surrounding cells
3. Record the cell configuration (3.5GHz/1.8GHz/900MHz), including boresight direction, downtilt angle, 5G NR BS and UE transmit power
4. Configure cells according to test configuration (stand alone, interference on control channel only, interference on control and data channel, record UL/DL interference level and thermal noise levels; preferably carry out the tests in low interference and noise locations.
5. The 5G end user device will be placed on the test vehicle and transmit/receive full-buffer UDP packets. The drive route should cover multiple cells and handover between cells should happen successfully. The duration of such test should exceed 30min. Log data according to section 3.5.2.1.4
 - o Optionally move scanner with end user device and log data according to section 3.5.2.1.5
6. (SUL testing only) turn off SUL function, UE goes into 3.5GHz cell, stop near the BS tower and start FTP UL/DL continuous packet transmission or video service or live broadcasting service, etc. UE moves away from the cell center, until UE lose connection. The duration of such process should last at least 10minutes to ensure the links are stable and enough data are captured.
7. (SUL testing only) turn on SUL function, and repeat step 6

3.5.2.2.4 Logging at gNB and UE side

- The device should log various data including RSRP, RS-SINR, UL/DL PDCP data rates, UL/DL MCS, UL/DL RB# per TTI, UL transmit power, DL transmission scheme, PDCCH SINR, DL PDSCH DMRS SINR, number of data streams, BLER.
- The gNB should record UL SRS SINR, PUSCH SINR, PUCCH SINR, UL IoT level.
- SUL testing additional recording requirement: test location information, UL/DL data rate on each frequency band and relative ratio with and without SUL, UE operating frequency bands; UL cell edge data rate (e.g. 500kbps, 1Mbps, 2Mbps...) and its corresponding RSPS so as to calculate SUL effective region,; signaling latency due to frequency band change.

3.5.2.2.5 Optional logging at scanner

Refer to Section 3.5.1.2.5

3.5.2.3 Success criteria

The coverage area achieving the data rates specified in section 3.5.1.2.4 should be recorded.

3.5.3 Outdoor to Indoor Coverage

3.5.3.1 Definition

This test case analyses how well an outdoor BS cover the indoor users, whether they are distributed at ground level, or across multiple floors. This helps understand the penetration loss due to building structure/materials, and the reachable depth with horizontal and vertical beamforming enhancement.

3.5.3.2 Test environment

3.5.3.2.1 Test setup

In this case we have a stand-alone cell covering a building whereas measurements are executed within the building. Dense urban deployments scenarios are considered according to section 3.2. The setup is illustrated in the figure below:



Figure 3.4.3-2 :- Stand-alone Cell coverage a building

3.5.3.2.1.1 Building coverage

Test the coverage performance inside a high-rise building within the trial area, place receivers at low/medium/high floors respectively and all locations indoors.

This test will record the power stats and the link quality stats at the UE, the SINRs and noise floor at the BS. UE can be 23dBm or 26dBm with Tx diversity.

3.5.3.2.1.2 Penetration test

Test environments should involve typical apartment complex and high-rise buildings (on different floors and different distances to the LoS window to the base station, behind concrete indoor walls...).

The difference to the previous test case, is to learn the coverage performance of the 5G BS at very difficult indoor locations, where building penetration loss is prohibitive. Such locations can be in basements and deep into large buildings.

This case is designed for testing beamforming capability of the BS and typical values of indoor penetration loss. This case can be reused for coverage of massive connections.

Additionally, SUL testing for single user and multiple users is added for completeness.

3.5.3.2.2 Test procedures

1. Activate cell under test
2. 4G devices and 5G devices are placed side by side,

ngmn e. V.

Großer Hasenpfad 30 • 60598 Frankfurt • Germany

Phone +49 69/9 07 49 98-04 • Fax +49 69/9 07 49 98-41

- Optionally place scanner at same end user device location
- 3. Activate data connection of the devices
- 4. Measure parameters defined in section 3.5.1.2.4 for data and control channels when moving from LOS (close to window) locations to NLOS (into the building) locations. The focus is on the downlink control channel, which will deploy adaptive beamforming or a single wide-beam with repeated transmission.
 - Optionally move scanner with end user device.
- 5. SUL testing:
 - Turn off SUL, UE connects to 3.5GHz NR cell, and move around the building and floors, need to ensure places where RSRP drops below -110dBm are included
 - when multiple UEs are used, need to ensure all places within the building are measured, UE distribution recommend to be excellent/good/med/bad=1:2:4:3;
 - turn on SUL and repeat the above process

3.5.3.2.3 **Logging at gNB and UE side**

Refer to section 3.5.2.2.3

3.5.3.2.4 **Optional logging at scanner**

Refer to section 3.5.2.2.5

3.5.3.3 **Success criteria**

The coverage area achieving the data rates specified in section 3.5.1.2.4 should be recorded and compared to LTE coverage for the same frequency band or accounting for the coverage difference in the case of different frequency bands for 5G NR and LTE.

3.5.4 **Indoor Coverage**

3.5.4.1 **Definition**

This section is mainly intended to understand the indoor coverage at high frequency bands (above 6GHz to mmWave). There are several aspects to consider when trying to understand indoor coverage, which may be different from the outdoor scenario.

3.5.4.2 **Test environment**

3.5.4.2.1 **Test setup**

- Indoor environment, e.g. office or shopping mall, LOS or NLOS according to section 3.2
- BS placement: on ceiling or wall-mounted
- The UL and DL coverage should be balanced, i.e. measurement result should be able to advise whether loss of connection is caused by UL or DL, and by which channel.

3.5.4.2.2 **Test configurations**

Tests may be carried out in a single cell deployment, whether multi-cell coverage can be tested depends on the progress of trials.

3.5.4.2.3 **Test procedures**

1. Activate cell under test
2. Place 5G end user devices
 - Optionally place scanner at same end user device location

ngmn e. V.

Großer Hasenpfad 30 • 60598 Frankfurt • Germany

Phone +49 69/9 07 49 98-04 • Fax +49 69/9 07 49 98-41



3. Activate data connection of the devices
4. Measure parameters defined in section 3.5.1.2.4 for data and control channels when moving within the indoor location
 - Optionally move scanner with end user device.

3.5.4.2.4 *Logging at gNB and UE side*

Refer to section 3.5.1.2.4

3.5.4.2.5 *Optional logging at scanner*

Refer to Section 3.5.1.2.5

3.5.4.3 Success criteria

The coverage area achieving the data rates specified in section 3.5.1.2.4 should be recorded.

3.6 Mobility

This section focuses on intra-cell mobility and inter-cell mobility (handover) scenarios.

Since a method to provide voice call service in 5G is not clear at its initial stage, only packet switched data scenarios are considered. Standalone (SA) and Non- Standalone (NSA) configurations are both covered in this section.

3.6.1 Intra-Cell mobility testing

This section considers testing the intra-cell mobility for different UE speeds and angles. In addition, performance (throughput, packet loss...) in different mobility scenarios and for different services should be verified.

3.6.1.1 Maximum angle mobility

3.6.1.1.1 Definition

Intra-cell mobility with different angles to transmission point is considered in this section.

This section covers mobility without RRC so some aspects of beam tracking are also included.

3.6.1.1.2 Test Environment

3.6.1.1.2.1 Test Setup

Deployment Scenario: Rural, urban may also be possible for low speeds. One 5G NR cell is needed. Test cell covers angle of 120 degrees. There should be more than one UE in order to track beam accurately.

3.6.1.1.2.2 Test Configuration

Drive test route should be similar to figure 3.6-1 below.

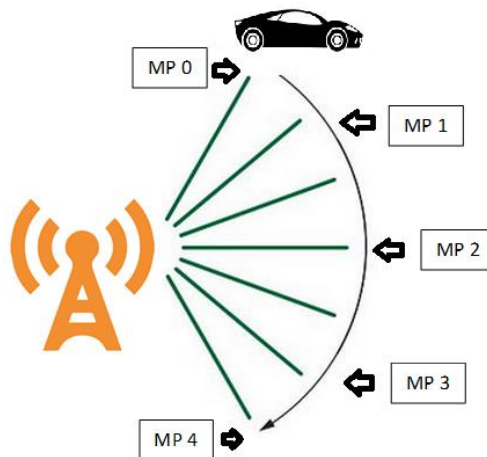

Figure 3.6-1 :- Drive test route

Below scenarios shall be considered:

Scenario	Speed (km/h)
Scenario 1	15
Scenario 2	60
Scenario 3	≥ 120

Table 3.6-1 :- Car Speed/velocity during test

3.6.1.1.2.3 Test Procedure

1. 5G NR Base Station (and for NSA MR-DC case LTE base station) is/are powered on and configured with related parameters
2. All the UE's are under 5G NR cell coverage.
3. UE's are powered on and complete initialization process.
4. UE's are successfully attached to the 5G network and are able to upload/download data.
5. All UE's start uploading/downloading data (e.g. from a file transfer protocol (FTP) server)
6. UE's should start movement from Measurement Point (MP) 0 and arrive at MP 4 on the route over the curve with an angle of 120 degrees as in Figure 3.6-1 :- Drive test route. Speed of the car should stay the same during test.
7. Continuously monitor DL/UL throughput, latency, packet loss and signal strength of beam.
8. The scenario shall be repeated with different speeds of car as in Table 3.6-1 :- Car Speed/velocity during test.

3.6.1.1.3 Success Criteria

- PS service shall continue without interruption.
- DL/UL throughput, user plane latency and packet loss should be observed between MP0 to MP4.
- Beam signal strength variations should also be tracked based on Beam ID (BRS based)
- RSRP/RSRQ/SINR variations should be observed.
- Maximum throughputs and minimum packet losses are expected between MP1 and MP3 and reverse on MP0 and MP4.
- User plane latency variations should be recorded. For eMBB service, user plane latency should be less than 10ms and for URLLC user plane latency should be less than 1ms.

The maximum throughput will depend on the selected frequency band and available bandwidth and other parameters of the test cell/trial configuration.

From the NGMN 5G whitepaper 6:50 Mbps DL and 25 Mbps UL throughput is expected on minimum for mobile car.

3.6.1.2 Maximum Doppler mobility

3.6.1.2.1 Definition

Intra-Cell Mobility during movement to and from a transmission point (Doppler Effect) is considered in this section.

3.6.1.2.2 Test Environment

3.6.1.2.2.1 Test Setup

Deployment Scenario: Rural, urban

One 5G NR cell is needed.

One UE is enough to observe Doppler Effect.

3.6.1.2.2.2 Test Configuration

Drive test route should be similar to Figure 3.6-2 :- Drive Test Route below.

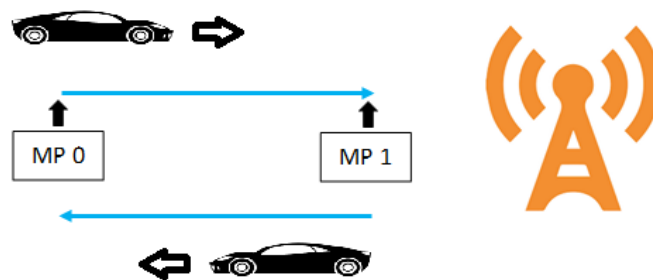

Figure 3.6-2 :- Drive Test Route

3.6.1.2.2.3 Test Procedure

1. 5G NR Base Station (and for NSA MR-DC case LTE base station) is/are powered on and configured with related parameters
2. The UE is under 5G NR Cell coverage.
3. UE is powered on and complete initialization process.
4. UE is successfully attached to the 5G network and are able to upload/download data.
5. The UE starts uploading/downloading data (e.g. from an FTP server).
6. UE should start movement from MP0 to MP1 with certain speed as in table 3.6-1. Speed of the car should stay the same during test.
7. Continuously monitor DL/UL throughput, latency, packet loss and RSRP/RSRQ/SINR.
8. UE should start movement from MP0 to MP1 with certain speed as in table 3.6-1. Speed of the car should stay the same during test.
9. Continuously monitor DL/UL throughput, latency, packet loss and RSRP/RSRQ/SINR.
10. The scenario shall be repeated with different speeds of car as in table 3.6-1.

3.6.1.2.3 Success Criteria

- PS service shall continue without interruption.
- Better DL/UL throughputs should be observed at lower speeds.
- Packet loss should be lower at low speeds.
- RSRP/RSRQ/SINR variations should be observed.
- User plane latency variations should be recorded and for eMBB service, user plane latency should be less than 10ms and for URLLC user plane latency should be less than 1ms.

The maximum throughput will depend on the used band & available bandwidth and other parameters of the test cell/trial configuration.

From NGMN 5G whitepaper, 50 Mbps DL and 25 Mbps UL throughput is expected on minimum for mobile car.

3.6.2 Inter-Cell Mobility (Handover) Testing

This section focuses on testing the inter-cell handover in the different scenarios.

Test scenarios are classified into two groups as SA (Standalone) and NSA (Non-Standalone).

3.6.2.1 SA Inter-Cell Handover

This section focus on inter-cell mobility for Standalone configuration

3.6.2.1.1 Definition

Handover from 5G NR cell to another 5G NR cell.

3.6.2.1.2 Test Environment

3.6.2.1.2.1 Test Setup

Deployment scenario: rural, urban, dense urban as defined in section 2.2.

Number of 5G NR cells should be at least two in order to trigger Handover during drive test. It is better to setup a cluster with more 5G NR cells.

The below KPIs should be focused on during test.

- Handover interruption time which is defined in the NGMN 5G Whitepaper as a time during which the user is not able to receive any user plane data, including inter-system authentication time, should be evaluated in different scenarios and configurations.
- DL and UL throughput variations and minimum DL/UL Throughput should be measured and verified during the handover
- Packets loss rate due to the handover procedure at different OSI layers should be measured during the trial.

3.6.2.1.2.2 Test Configuration

The tests should be performed for all the scenarios mentioned in table 3.6-2 below:

Speed ranges	0-15km/h	15-60 km/h	60-120 km/h	120-500 km/h
TCP	Config 1	Config 3	Config 5	Config 7
UDP	Config 2	Config 4	Config 6	Config 8

Table 3.6-2 :- Handover trial configuration

5G NR can be either collapsed gNB (without CU-DU split) or CU-DU Split.

For Intra-band handover (Cell 1 and Cell 2 are in same band) and Inter-band handover (Cell 1 and Cell 2 are in different bands) cases, below cases should be performed.

- Scenario 1: Intra-gNB handover (without CU-DU split) within 5G NR
Cell 1 and Cell 2 are in same gNB (Figure 3.6.2-3 :- Scenario 1 and 2 for intra/inter-gNB handovers).
- Scenario 2: Inter-gNB handover (without CU-DU split) within 5G NR
Cell 1 and Cell 2 are in different gNB (Figure 3.6.2-3 :- Scenario 1 and 2 for intra/inter-gNB handovers).

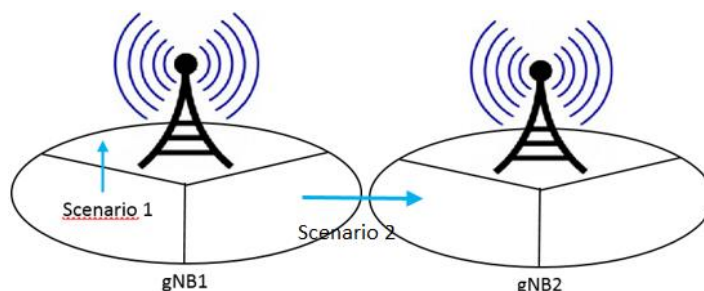

Figure 3.6.2-3 :- Scenario 1 and 2 for intra/inter-gNB handovers

- Scenario 3: Intra Distributed Unit (DU) handover within 5G NR
Cell 1 and Cell 2 are in same DU (Figure 3.6.2-4 :- Scenario 3, 4 and 5 for handovers in CU-DU function split case).
- Scenario 4: Intra Central Unit (CU) inter DU handover within 5G NR
Cell 1 and Cell 2 are under same CU but different DU (Figure 3.6.2-4 :- Scenario 3, 4 and 5 for handovers in CU-DU function split case).
- Scenario 5: Inter CU handover within 5G NR

Cell 1 and Cell 2 are in different CU (Figure 3.6.2-4 :- Scenario 3, 4 and 5 for handovers in CU-DU function split case).

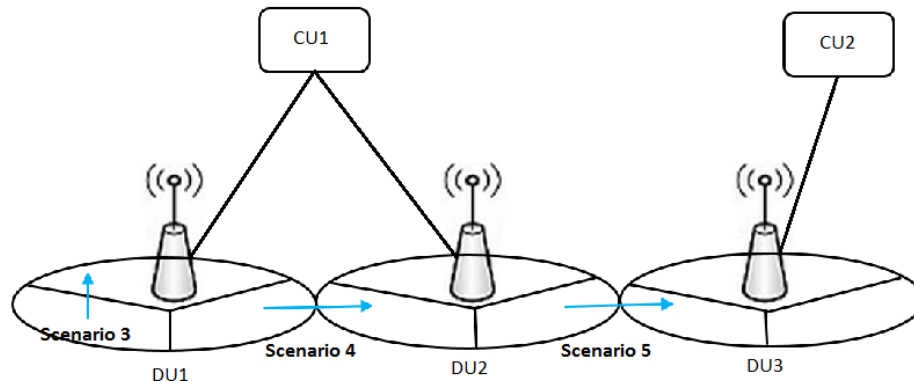

Figure 3.6.2-4 :- Scenario 3, 4 and 5 for handovers in CU-DU function split case

It is recommended to set up a cluster of cells which have all CU/DU possible configurations.

3.6.2.1.2.3 Test Procedure

1. 5G NR Base Stations are powered on and configured with handover related parameters (neighbor cells, thresholds etc...)
2. All the UEs are under Cell1 coverage.
3. UE's are powered on and complete initialization process.
4. UE's are successfully attached to the 5G network and are able to upload/download data.
5. All UE's start uploading/downloading data (e.g. from an FTP server)
6. For all scenarios above (scenario 1 to 5), UE should move from Cell 1 to Cell 2 with velocities given in table 3.6-2.
7. The handover procedure should be successfully performed for all UE's.

3.6.2.1.2.4 Success Criteria

Minimum 20 valid samples are required for result evaluation.

- DL and UL Throughput:
DL/UL Throughput variations and Minimum DL/UL throughputs during handover at different speeds should be continuously monitored.
From NGMN 5G whitepaper, 50 Mbps DL and 25 Mbps UL throughput is expected on minimum for mobile car.

- Packet loss:

It is necessary to report precisely in which layer the packet loss is measured in the trial:

- At network layer (layer 3 in OSI model)
IP Packet Loss Rate (IP PLR)
- At transport layer (layer 4 in OSI model)
TCP PLR or UDP PLR (equal to IP PLR)
- At application layer (layer 5 in OSI model)
Frame erasure rate (FER) to evaluate the information loss

- Interruption time:

User plane handover interruption time should be 0 ms [5].

Note: From [9]; NR mobility scheme aims to define handover with an interruption time as close to zero as possible while only having single Tx/Rx in the UE, and **0 ms interruption** at least for the case that the UE supports simultaneous Tx/Rx with the source cell and the target cell.

3.6.2.2 NSA Inter-Cell Mobility

This section focus on inter-cell mobility for Non-Standalone Configuration

3.6.2.2.1 Definition

For Multi RAT Dual Connectivity case, mobility from master cell group (MCG)/ secondary cell group (SCG) to another MCG/SCG scenarios are considered here.

From RAN #75 meeting:

An **updated REL-15 workplan** for eMBB was endorsed [10] completing stage 3 for Non-Standalone (NSA) 5G-NR eMBB (incl. low latency support) **with architecture option 3** by Dec.17 and an intermediate implementable version with frozen ASN.1 for Non-Standalone 5G NR eMBB by March 18.

As mentioned in [11], for NSA MR-DC with the EPC configuration is as follows.

E-UTRAN supports MR-DC via E-UTRA-NR Dual Connectivity (EN-DC), in which a UE is connected to one eNB that acts as a MN and one gNB that acts as a SN. The eNB is connected to the EPC and the gNB is connected to the eNB via the X2 interface.

As mentioned in [9], it is assumed that CN-RAN connection is like figure 3.6-5 below and LTE eNodeB is the master node. For this scenario, there exists one C-plane connection between CN and RAN. U-plane data is routed to RAN directly through CN on a bearer basis (green line in Figure 3.6-5). Alternatively, U-plane data flow in the same bearer is split at RAN (red line in Figure 3.6-5).

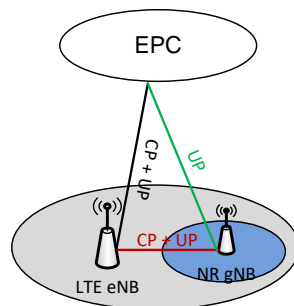

1) Data flow aggregation across LTE eNB and NR gNB via EPC

Figure 3.6.2-5 :- NSA CN-RAN Connection

3.6.2.2.2 Test Environment

3.6.2.2.2.1 Test Setup

Deployment scenario: Rural, Urban, Dense urban

The UE is attached to master LTE cell and secondary 5G NR cell is added during connected mode.

At least 2 Master LTE eNB and 3 Secondary 5G NR gNB is needed in order to setup below scenarios.

It is better to setup a cluster with more LTE/ 5G NR cells.

Below KPI's should be focused on during test.

ngmn e. V.

Großer Hasenpfad 30 • 60598 Frankfurt • Germany

Phone +49 69/9 07 49 98-04 • Fax +49 69/9 07 49 98-41

- Handover interruption time which is defined in the NGMN 5G Whitepaper 6 as a time during which the user is not able to receive any user plane data, including inter-system authentication time, should be evaluated in different scenarios and configurations.
- DL and UL throughput variations and minimum DL/UL Throughput should be measured and verified during the handover.
- Packets loss rate due to handover procedure at different OSI layers should be measured during the trial.

3.6.2.2.2.2 Test Configuration

The tests should be performed with all the velocities/scenarios mentioned in table 3.6-2 above.

For each configuration above, below scenarios shall be considered:

- Scenario 1: MeNB same, SgNB same, SCG different (Figure 3.6.2-6 :- Intra MeNB Mobility Scenarios) [11].
- Scenario 2: MeNB same, SgNB different (Figure 3.6.2-6 :- Intra MeNB Mobility Scenarios) [11].

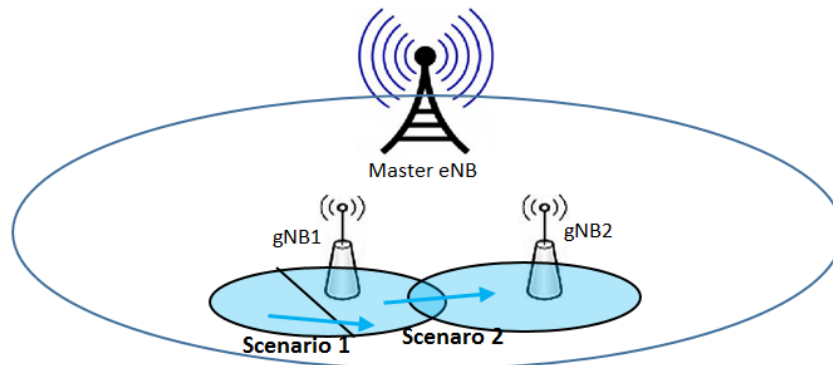

Figure 3.6.2-6 :- Intra MeNB Mobility Scenarios

- Scenario 3: MeNB different, SgNB same (Figure 3.6.2-7 :- Inter MeNB Mobility same SgNB Scenario) [11].

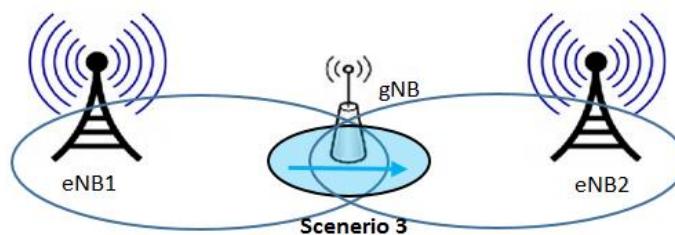

Figure 3.6.2-7 :- Inter MeNB Mobility same SgNB Scenario

- Scenario 4: MeNB different, No SgnB (Figure 3.6.2-8 :- Inter MeNB Mobility no SgNB Scenario) [11].

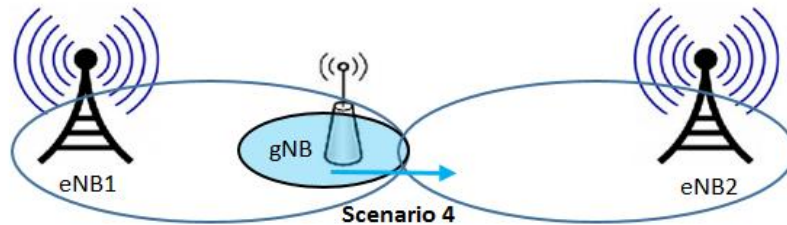

Figure 3.6.2-8 :- Inter MeNB Mobility no SgNB Scenario

- Scenario 5: MeNB different, SgnB different (Figure 3.6.2-8 :- Inter MeNB Mobility no SgNB Scenario) [11].

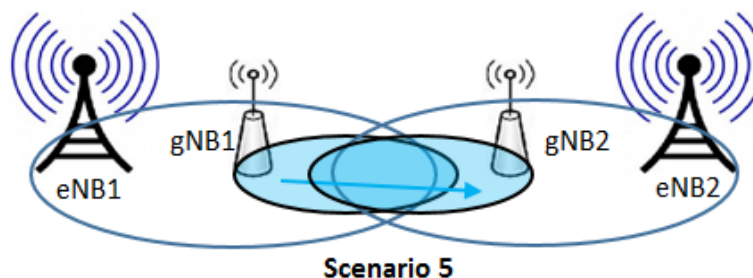

Figure 3.6.2-9 :- Inter MeNB Mobility different SgNB Scenario

3.6.2.2.2.3 Test Procedure

1. LTE and 5G NR Base Stations are powered on and configured with handover related parameters (neighbor cells, thresholds etc...)
2. All the UE's are under Master LTE eNB and Secondary 5G NR gNB coverage.
3. UE's are powered on and complete initialization process.
4. UE's are successfully attached to the LTE/5G network with MR-DC and are able to upload/download data.
5. All UE's start uploading/downloading data (e.g. from an FTP server)
6. For all scenarios above (scenarios 1 to 5), UE should move from according to the test scenario shown in figures 3.6-6, 3.6-7, 3.6-8 and 3.6-9 with velocities given in table 3.6-2.
7. Be sure that handover procedure is successfully performed for all UE's.

3.6.2.2.2.4 Success Criteria

Minimum 20 valid samples are required for result evaluation.

- DL and UL Throughput:
DL/UL Throughput variations and Minimum DL/UL throughputs during handover at different speeds should be continuously monitored.
From NGMN 5G whitepaper, 50 Mbps DL and 25 Mbps UL throughput is expected on minimum for mobile car.

- Packet loss:

it is necessary to report precisely in which layer the packet loss is measured in the trial:

- At network layer (layer 3 in OSI model)
IP Packet Loss Rate (IP PLR)



- At transport layer (layer 4 in OSI model)
TCP PLR or UDP PLR (equal to IP PLR)
- At application layer (layer 5 in OSI model)
Frame erasure rate (FER) to evaluate the information loss

- Interruption time:

For Intra Master eNB handover (scenarios1&2) user plane handover interruption time should be 0 ms. For Inter Master eNB handover (scenarios3,4&5) user plane handover interruption time should be similar to LTE.

3.7 Reliability and Retainability

Reliability is one of the main characterizing features of 5G where 5G NR is expected to add much improved performance in terms of reliability as compared to LTE. We cover reliability in the NSA architecture and some aspects of the SA option as not all aspects of the SA architecture have been defined by 3GPP.

We also cover retainability in this framework in order to understand what gains 5G NR provides in terms of this KPI.

3.7.1 Definition

Reliability can be expressed by the success probability of transmitting a set number of bytes within a certain delay. It is the time it takes to deliver a small data packet from the radio protocol layer 2/3 SDU ingress point to the radio protocol layer 2/3 SDU egress point of the radio interface, at a certain channel quality (e.g., coverage-edge).

Retainability KPIs are used to evaluate the capability of the network to retain a service by a UE for a desired duration once the user is connected to the service. These KPIs can be calculated per cell or per cluster.

Call drop rate (CDR), call setup complete rate are the main retainability KPIs and are defined below:

- **Call drop rate⁸:** The call drops when the eNodeB initiates an active ERAB release process by (E-RAB Release Indicator or UE Context Release Request message with an abnormal reason in the Cause field (anything other than Normal Release Detach, User Inactivity, cs fallback triggered, UE Not Available for PS Service, or Inter-RAT redirection). This KPI can be used to evaluate the call drop rate of all services a cell or a cluster, including VoIP service.

$$\text{CDR} = (\text{ERAB_Abnormal_Release} / \text{ERAB_Release}) * 100 \% \quad (3.7-1)$$

- **Call setup complete rate:** This KPI will evaluate the success rate in totally 4 phases:
 - RRC setup phase
 - S1 Signaling connection establishment phase
 - Service E-RAB setup phase and
 - Service E-RAB release Phase

This KPI can be used to evaluate the call setup complete rate of a service in a cell or cluster, which means the rate of normal termination of a service once it is setup by the UE.

- **Dual connectivity drop rate:** This KPI can be an indication of the availability of NR service through Dual Connectivity and only be applicable in NSA deployment scenarios. In case of SCG radio link failure in E-N dual connectivity, the UE reports SCG failure information to MCG. The number of such failure reports measured over a given time window provides a measure of call drop rate in dual-connectivity with NR configured as SCG.

3.7.2 Test Environment

3.7.2.1 Test setup

Reliability and retainability testing should be done in different settings.

- **Scenario 1:** 1 UE – 1 BS and test the UL and DL reliability as the UE moves from good coverage to worse coverage (until the UE is out of coverage).

⁸ As defined for LTE.

- **Scenario 2:** 1 UE – multiple BSs and test the DL reliability in different interference scenarios (starting with minimum interference to the worst case interference where all interfering BSs are pointing their main beam towards the UE).
- **Scenario 3:** Multiple UEs– multiple BSs and test the UL reliability in different interference scenarios.
- **Scenario 4:** Multiple UEs - 1 BS and test the UL and DL reliability as the test UE moves from good coverage to worse coverage while other UE's are connected to the same BS and have UL or DL traffic.

3.7.2.2 Test configuration

Deployment options: Dense Urban (section 3.2.2) and Urban Macro (section 3.2.3).

- Conf. 0 (eMBB service)
 - NR NSA Deployment with collocated LTE eNBs⁹.
- Conf. 1 (eMBB service):
 - NR SA Deployment
 - System BW:
 - 100 MHz for eMBB < 6 GHz
 - 800 MHz for eMBB > 6GHz
 - DL peak rate test: DL/UL ratio: full DL
 - UL peak rate test: DL/UL ratio: full UL
- Conf. 2 (URLLC service):
 - NR FDD SA Deployment
 - 60kHz sub-carrier spacing
 - 1.2us CP length
 - TTI length: 0.125ms
 - System BW: 100 MHz (< 6 GHz)
 - DL peak rate test: DL/UL ratio: full DL
 - UL peak rate test: DL/UL ratio: full UL

3.7.2.3 Test procedures

The following test procedures are defined for the reliability and retainability tests:

1. Select sector pointing into the trial area and make sure that only one test UE is connected to this sector.
2.
 - a. For scenario 1: make sure that all interfering cells are either not transmitting or are not pointing their main beam to the test UE.
 - b. For scenario 2: Have all interfering BSs transmit towards the coverage area of the serving cell of the test UE.
 - c. For scenario 3: Have all interfering UEs transmit in the UL to generate interference to the test UE.
 - d. For scenario 4: Make sure that all interfering cells are either not transmitting or are not pointing their main beam to the test UE. Make sure all background UE's are connected to the same BS as test UE and have some UL or DL traffic.
3. Start moving the test UE from the cell center towards the cell edge in scenario 1 and from low interference to high interference conditions in scenarios 2 and 3.
4. Perform a download/upload from/to UE using UDP or TCP (using iperf).
5. Log the reliability, CDR and CSCR as defined in the definition section.
6. Repeat steps 3-5 several times with different locations and traffic load.

⁹ For NSA retainability needs to focus on the NR connection only as losing the NR connection does not mean losing the connection completely (the UE might be still connected to the LTE carrier).



7. Repeat test for different UE speeds {3mph, 25 mph, 60mph}

3.7.3 Success criteria

For reliability, the expected output would depend on the use case.

For eMBB, the requirement on reliability for one transmission of a packet of 32 bytes with a user plane latency of 8ms is recommended to be at least 10^{-2} .

A general URLLC reliability requirement for one transmission of a packet is $1-10^{-5}$ for 32 bytes with a user plane latency of 1ms [5].

For mobility use cases, the requirements for communication availability, resilience and user plane latency of delivery of a packet of size 300 bytes are as follows [5]:

- Reliability = $1-10^{-5}$, and user plane latency = 3-10 msec, for direct communication via sidelink and communication range of (e.g., a few meters)
- Reliability = $1-10^{-5}$, and user plane latency = 3-10 msec, when the packet is relayed via BS.

As for retainability, the recommended requirement is to be an order of magnitude better than LTE.

3.8 User experience

The end-to-end performance that finally drives the user experience can be best reflected by evaluating the quality of experience (QoE). While quality of service (QoS) is based on technical and lower layer parameters in RF, signaling, and IP, QoE more often uses events on application layer or above. QoE goes beyond the pure technical measures and considers the end-customer, who interacts with the device, its user-interface, the network, and the service behind it. QoE is providing an end-to-end view and is often based on perceptual feedback given by a user. The applied metrics are more and more considering human perception and cognition. QoE is necessary for benchmarking where technologies and networks are compared under real use cases and end-to-end experience; this enables real user-orientated optimization of networks and offered services.

While in 4G networks the standard QoE tests are commonly related to voice and video quality estimation, 5G is supposedly having an increasing amount of services bearing a wide range of requirements. For this reason, a broader testing of QoE, based on service performance testing, is required for 5G.

In LTE and other existing technologies, these tests are executed using a test SW integrated into commercial smartphones to really reflect the end user perception. Although 5G is introducing UEs that can be very different from traditional mobile phones, the 5G use case initially will be enhanced Mobile Broadband (eMBB) that will most likely be served by smartphone type of UE. For pre-commercial trials in 5G this will rely certainly on early UE implementations coming from chipset suppliers. Therefore, a strong cooperation between the test solution and the early UE implementation is essential to execute these application tests for Quality of Experience in such an early phase.

3.8.1 Definition

Everyone has a different perception of "quality". For meaningful results, you need to ask a statistically significant number of people to judge and to assign quality scores to samples of speech, music, video, game playing etc. These samples are experienced by the human subjects under identical and tightly controlled conditions.

The quality scores, that are derived in this way, are only valid for the specific conditions in which the tests were conducted and for the specific questions that the human subjects were asked. To produce a truly useful measure of "quality", the conditions should reflect real life as closely as possible. Such conditions include also the interaction of the user itself with the system. If we consider for example mobile Apps, these interactions include which buttons the user pushes, or how he/she swipes to change the graphical user interface (GUI) view, rather than how the service is effectively used. There is then the need of properly defining user flows that represent the average interactive behavior of the user for a specific service. The user flows will be then the foundation for the definition of the test cases to be used for the QoE evaluation.

3.8.1.1 Service Classification

The diversification of services expected for 5G requires a concrete categorization to have a sharp picture of what users will be expected to interact with.

This is essential for understanding which type of QoE needs to be addressed in the trial phase. A possible categorization is coming from [12] and encompasses both the services normally accessible via mobile phones UEs and the ones that can be integrated in e.g. gaming consoles, advanced VR gear, car units, or IoT systems.

<i>Identifier</i>	<i>Use Case</i>	<i>Description</i>
<i>VR</i>	Virtual Reality	Based on mobile phone-based or dedicated VR gear
<i>GA</i>	Gaming	Used in mobile phones or connected consoles
<i>AR</i>	Augmented Reality	For mobile phones or AR glasses/head gear
<i>CS</i>	Content Distribution Streaming Services	Typical streaming service in DL. This includes content on demand as well as live streaming.
<i>LS</i>	Live Streaming Services	Modern user-based streaming in UL. Examples in Facebook live, Periscope
<i>SN</i>	Social Networking	Content posting in online platforms
<i>HS</i>	High Speed Internet	Traditional browsing or files up/download
<i>PM</i>	Patient Monitoring	Transmission of life critical and/or low latency medical data
<i>ES</i>	Emergency Services	Emergency services such as «panic button», communication with emergency dispatch center
<i>SM</i>	Smart Metering	Deployed metering sensors, mostly IoT devices.
<i>SG</i>	Smart Grids	Electricity meters and actuators for grid management
<i>CV</i>	Connected Vehicles	Services for V2X interconnection, road safety, road traffic management and steering

Table 3.8-1 :- QoE Service characterization

While not all the listed services are valuable use cases for QoE investigation in a first place, and priorities in a pre-commercial trial, some of them should be considered foundations as a modern use of a wireless network: VR, GA, AR, CS, LS, SN, HS.

Out of these services, highest priority should be given to CS, SN, HS. For each of the services, a reference one should be picked up amongst the most popular and with the highest customer-base. This would ensure that the pre-commercial trial is planned for an immediate use by end customers.

It comes without saying that each of the services needs to have defined different measurements and KPIs for QoE evaluation.

3.8.1.2 Human Perception-based Quality Evaluation

When we talk about voice and video quality, we consider the quality in terms of Mean Opinion Score (MOS).

Video is usually obtained in visual tests with human viewers under controlled experimental conditions. The common MOS scale ranges from 1.0 (bad) to 5.0 (excellent) – see Table 3.8-2 :- Five-Point Quality Scale below. The MOS is the average over all individual scores for a video clip obtained with 24 test persons. Laboratories for voice and video tests have to fulfil a large set of strict requirements with respect to room acoustics, lighting, test devices, and the quality of the presentation equipment.

Examples of visual experimental setups can be found in [13].

The Absolute Category Rating (ACR) tests are used to simulate such situations and do not involve a direct comparison to a reference stimulus. In such a test the person must rate the quality on an absolute scale based on his or her own expectation and experience. The most common rating method for an ACR test is a following five-point scale, which has verbal categories in the native language of the test subjects.

Score	English	German	French	Spanish
5	excellent	ausgezeichnet	excellente	excelente
4	good	gut	bonne	buena
3	fair	ordentlich	assez bonne	regular
2	poor	dürftig	médiocre	mediocre
1	bad	schlecht	mauvaise	mala

Table 3.8-2 :- Five-Point Quality Scale

Each test subject provides a quality score for a stimulus or a test condition, for example, a pre-recorded speech or video sample of a few seconds in length. The experiment yields a collection of individual scores that is independent from the scale that was used. These scores can be a collection of even integer values, if you use 'buttons' in the experiment for scoring, or real numbers, if you use a continuous scale and score with a slider device or a computer mouse.

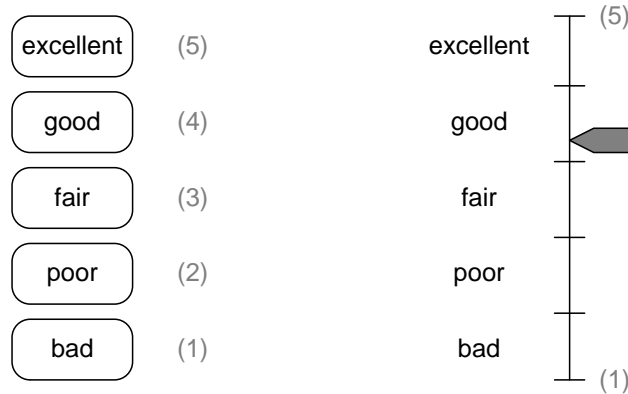

Figure 3.8-1 :- Examples of Five-Point scales as used in ACR experiments

The example ACR scales in **Fehler! Verweisquelle konnte nicht gefunden werden.** are typically used in ITU-T and ETSI activities. To be accepted by ITU or ETSI an algorithm must proof with significant amount of data and lab experiments that it reflects the medium end user perception.

Video quality is defined for the experimental setup as it was tested. Normally, the display size and the viewing distance are fixed in an experiment.

In the past, separate experiments and models were made for individual resolutions and display sizes, e.g. experiments purely for QVGA (240p) or VGA (480p). These experiments and resulting models do not allow the comparison of MOS values across different resolutions.

Recent experiments and models have changed this paradigm. Today, high-resolution screens and displays are used in subjective tests. All videos despite their native resolution are displayed on this screen. It means a 480p video is up-scaled to 1080p and presented on the full-HD display that is state of the art for today's smartphones. This new approach allows the direct comparison of resolutions under identical viewing conditions. In the aforementioned example, a 480p video shown on a 1080p screen looks blurrier than a native 1080p video would look on this screen. This new approach reflects the reality in today's video streaming environment, where resolution of the video is just one dimension used for efficient compression and all those videos are watched on a full-HD smartphone.

For voice and video services as well as VR / AR applications, a Mean Opinion Score (MOS) value should be measured to reflect the medium user perception. With algorithms using MOS models an objective evaluation of the perceived subjective quality is available.

The importance of Video services is increasing (in 2021 78% of the data traffic on mobile networks globally is forecasted to be video vs. 60% today). VR / AR services are also based mainly on video content. Therefore, the next chapter will cover video quality testing approaches.

ngmn e. V.

Großer Hasenpfad 30 • 60598 Frankfurt • Germany

Phone +49 69/9 07 49 98-04 • Fax +49 69/9 07 49 98-41

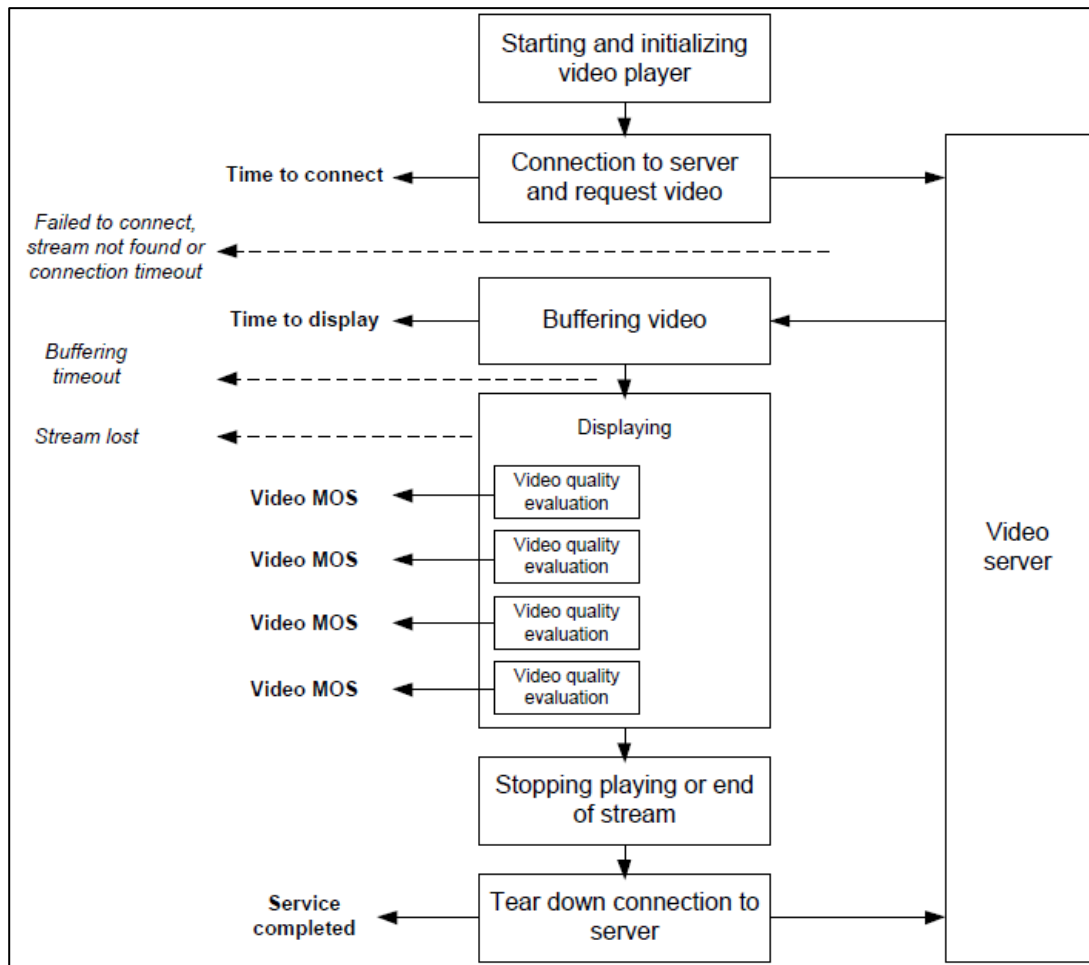

Figure 3.8-2 :- Flow of a typical video service measurement at service level

The quality of video services (user experience) is determined by

- the server accessibility (application accessibility)
- the waiting time (time to first picture) → user defined timeout (emulates the user’s patience) leads to a “fail”
- very importantly the picture quality (MOS for each 10s interval of a video, and certainly as the average MOS for the whole video)
- freezing / stalling of the video in %
- lost streams (constant freezing)
- jerkiness in % (if frame rate is not high enough, e.g. < 20 fps, the video is not perceived as fluent)

All mentioned test results are provided separately whereas the stalling and jerkiness are also affecting the MOS value for the relevant 10s interval of a video.

3.8.2 Test environment

3.8.2.1 Test setup

3.8.2.1.1 Content Distribution Streaming Service QoE



One of the most popular type of service that is currently flooding the 4G networks is the streaming of multimedia content. Thinking about services such as YouTube, Netflix, Spotify, the network carries on demand entertainment or live streaming events and they are a key application to consider in the context of the 5G services.

In particular, for pre-commercial trials of 5G (but also in running networks) the impact of the network on the video quality is of highest importance. Therefore, the type of video service used for testing is essential for the intended results:

- a) Live, real-time video
- b) Video on demand

The evaluation of live, real-time video is a demanding test case and challenges network performance more than other video delivery methods. Real-time videos cannot be buffered or pre-stored by the video client (on the device) otherwise they lose the real-time capability. Simple Video on Demand (VoD) with progressive download, where a large portion of the video can be pre-stored in the buffer on the device before it is displayed, can bridge longer network outages without stopping the display.

In contrast, for live, real-time video, the buffer is much shorter, typically a few seconds. The consequence is that live video buffers cannot bridge network outages longer than this time, after that the buffer runs empty and the video freezes. To avoid freezing, video service providers are actively monitoring the video connection and adapting the compression and resolution frequently to the channel capacity.

Testing with live, real-time video (CS from a live streaming infrastructure) is recommended for pre-commercial 5G trials since it results in a much more sensitive view to the real network performance than testing services using progressive download (video on demand), where most network issues are invisible.

Customers make use of such services everywhere: home, public transportation, cars, trains, etc. These services are downlink centric with extremely high data throughput requirements in the downlink; while the uplink is only used for controlling the stream.

Nowadays streaming services such as Netflix requires 5 Mbit/s for HD video and 25 Mbit/s for ultra-HD. The quality of the video can be downgraded if the user network is not good enough; being 0.5 Mbit/s the absolute minimum that the service requires for minimal operation [14]. Video requirements are to be considered first, since audio-only streams require much less bandwidth.

There are several ways to estimate the quality of such services. The ITU-based way of testing uses image-based quality metric based on fully decoded video output or bitstream-based metrics that evaluate the IP traffic and headers only. Alternative, generalized methods are though including other ways to measure important KPIs such as the service Application Programming Interface (API).

Another important aspect to be considered are the most common actions that a user would perform while interacting with the service.

It is though priority for Pre-Commercial Trials, to use as much standardized methodologies as possible. For this reason, the ITU-based testing method is considered the preferred one. Other methodologies, such as the Generalized Method, are listed for awareness, and in the case the ITU-based is not supported by the provided UEs.

3.8.2.1.1.1 Test setup for ITU-based method

Objective measures predict quality through signal analysis. They predict video quality as perceived in visual experiments by a group of viewers. Such objective models are commonly distinguished by the information they get for analysis.

At the highest level, models can be separated by their use case. The use case is typically split into two types: **image-based models and bitstream-based models**.

ngmn e. V.

Großer Hasenpfad 30 • 60598 Frankfurt • Germany

Phone +49 69/9 07 49 98-04 • Fax +49 69/9 07 49 98-41

Image-based models require access to the decoded video frames for analysis. They are typically end-point measures applied at or connected to the end user’s video client where the video is available “as video”.

Bitstream-based models analyze only the IP stream of the video transport. Of course, the bitstream analysis has limited information to use for quality estimations, particularly if the transport or the content is encrypted. Because bitstream-based models evaluate IP traffic only, they are suited for in-service monitoring in the network, where no decoded video is available.

Image-based video quality measures:

Fundamentally, there are “no-reference” and “full-reference” models. A no-reference model only analyzes the received/recorded video signal with no knowledge of the source video. A full-reference model gets the received signal and the reference signal for comparison. This reference signal is the high-quality input signal in the transmission chain. Full-reference models have very detailed information about the changes in the picture due to the comparison with the reference signal. Full-reference models use pixel- and frame-wise comparison with the reference. However, full-reference measures are very sensitive to changes in image size such as stretching, warping or rescaling. They predict a high MOS value if the decoded video is a perfect replication of the reference.

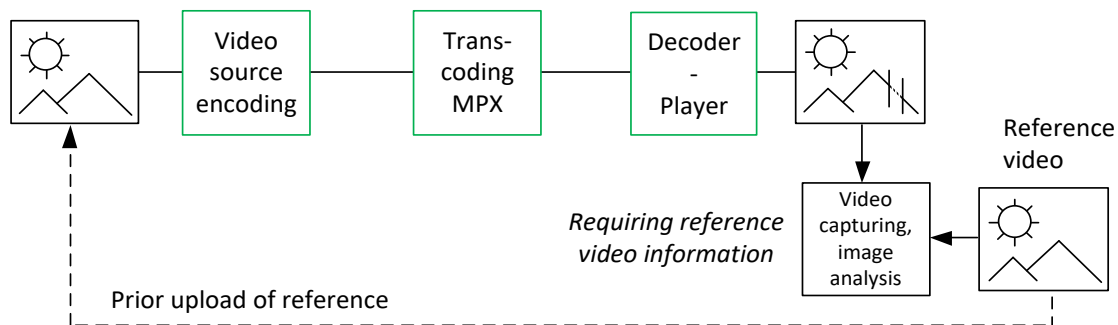

Figure 3.8.2-3 :- Principle of the video flow in streaming quality measurement using a full-reference method

Figure 3.8.2-3 :- Principle of the video flow in streaming quality measurement using a full-reference method shows the basic flow of streaming and a related full-reference measurement approach [15]. At the beginning, there is always a high-quality video source available. For test and measurement purposes, this source video is in uncompressed format.

Compression by video encoding inserts artifacts and information is lost. Afterwards the channel might lose or delay packets, and the player may have different strategies for concealing lost or skipped packets and can even try to smear compression artifacts. The screen outcome of the player is captured (as bitmaps) and transferred to the scoring algorithm.

The main restriction of full-reference measurements is their limited application in real field measurements because they always require a pre-uploaded reference. They cannot be used for live video or for commercial services (Netflix, Hulu, etc.), which do not accept private uploads. In addition, many services such as YouTube re-encode videos, thereby altering the reference video. Full-reference video measures are excellent for strictly defined test setups such as in a lab for optimizing codecs or in controlled streaming environment for contacting a self-hosted video server.

Conversely, a no-reference model (Figure 3.8-4) will merely evaluate the incoming and captured video without the requirement to know the source material.

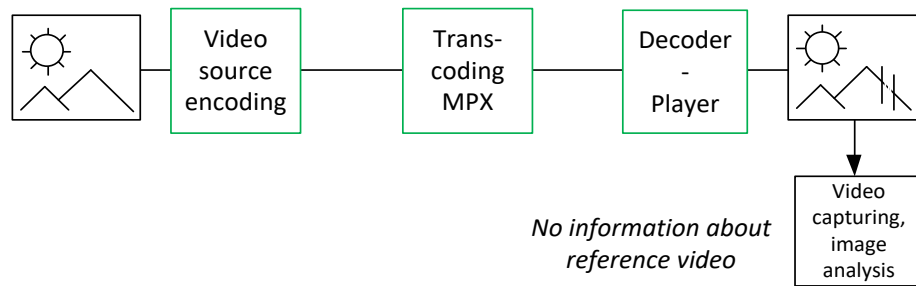

Figure 3.8.2-4 :- Principle of the video flow in streaming quality measurements using a no-reference method [16]

No-reference models simply analyze the images for known, expected distortions such as un-sharpness, blocks, corruptions and stalling. Consequently, they can be applied to any video, and there is no restriction with regard to rescaling or resolution changes or accessing live video. This makes no-reference measures, even though they may be less accurate, more versatile in their usage.

Today, there are also image-based models that take additional information from the bitstream, such as codec type, size of the compressed video frame and correct reception of packets. This information helps to significantly increase the accuracy of no-reference models.

Bitstream-based video quality measures:

Pure bitstream-based models analyze only the IP stream, where the video is transported in an encoded (and mostly encrypted) manner (see Figure 3.8.2-5 :- Principle of the video flow in streaming quality measurements using a bitstream-based model).

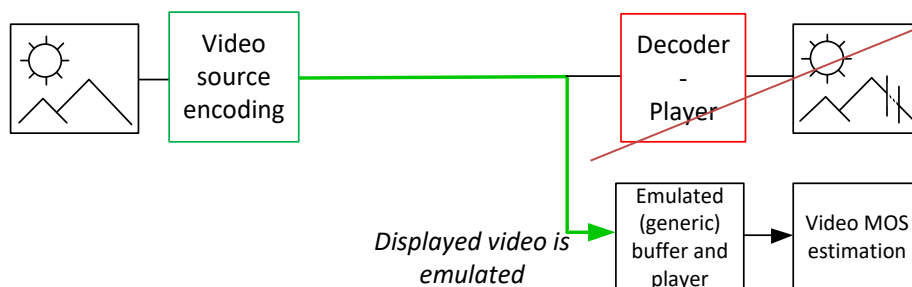

Figure 3.8.2-5 :- Principle of the video flow in streaming quality measurements using a bitstream-based model

Pure bitstream-based models have a limited scope; they cannot consider the currently used video buffer, the video decoder/player or concealment techniques. In the case of non-encrypted transmission, they may derive limited knowledge of content characteristics. In the case of encryption, the video quality estimation is based on META information such as bitrate and packet jitter only. Bitstream-based models are designed for dedicated individual scopes that narrow down the application area. They are made for in-service monitoring in a dedicated IP environment.

There is another restriction: bitstream-based models always consider only the IP link they are connected to. They cannot consider IP connections beyond any transcoding or re packaging. If video content is compressed strongly and a transcoder re-encodes it to e.g. HD by applying a high bitrate, the bitstream-based model will recognize this video as high-quality HD and estimate a high score, even though there are distortions from the first part of the connection.

There are recommendations by ETSI standards for measuring voice quality (e.g. [17] - POLQA) and video quality in mobile networks (e.g. [16]– VMon as an image-based, no-reference hybrid video quality measures).

There are a few ETSI documents coming from the Speech and multimedia Transmission Quality working group that define parameters and guidelines for Quality of Experience tests:

ETSI TS 102 250-2 [18]:

Speech and multimedia Transmission Quality (STQ); QoS aspects for popular services in mobile networks;
Part 2: Definition of Quality of Service parameters and their computation

ETSI TR 102 493 [19]:

Speech and multimedia Transmission Quality (STQ); Guidelines for the use of Video Quality Algorithms for Mobile Applications

These ETSI standard documents recommend to use [16] – VMon (image-based, no-reference hybrid video quality measure) for all kinds of video services in mobile networks.

3.8.2.1.1.2 Test setup for Generalized Method

3.8.2.1.1.2.1 MOS Concept Generalization

The MOS concept can be generalized. In many cases, it is still unclear which are the relevant factors influencing the perceived quality of a service. It is then possible to start from the concept that the MOS computations are based on an interpolation function that takes measured atomic KPIs as input and translates them into a continuous scale between 1 and 5.

A homogenous evaluation of QoE for all the 5G services is needed to have an easy way of comparison between the different services. For this reason, it is possible to apply interpolation functions to all the measured atomic KPIs for both aggregation and comparison. By using the proposed two types of interpolations, the vast majority of KPIs can be translated into a MOS-type of measurement, easy to be averaged in order to provide a simple, unified evaluation.

3.8.2.1.1.2.2 Type I

This function performs a linear interpolation on the original data. Suppose that min_{KPI} and max_{KPI} are the worst and best values of a KPI from a reference case. This function maps a value, v , of a KPI, to v' in the range [1.0, 5.0] by computing

$$v' = \frac{v - min_{KPI}}{max_{KPI} - min_{KPI}} (5.0 - 1.0) + 1.0 \quad (3.8-1)$$

This function is to be used for KPIs which will be scored by a simple linear interpolation from the worst and best expected values from a reference case.

If a future input case falls outside the data range of the KPI, it will be set to the extreme value min_{KPI} (if it is worse) or max_{KPI} (if it is better).

3.8.2.1.1.2.3 Type II

This function performs a logarithmic interpolation and is inspired in the opinion model recommended by the ITU-T in [20] for a simple web search task. This function maps a value, v , of a KPI, to v' in the range [1.0, 5.0] by computing

$$v' = \frac{5.0 - 1.0}{\ln((0.003 min_{KPI} + 0.12) / min_{KPI})} \cdot (\ln(v) - \ln(0.003 min_{KPI} + 0.12)) + 5 \quad (3.8-2)$$

This function is to be used for KPIs which reflect single time events such as search time or time to load first frame. Therefore, for such a single interaction, max_{KPI} (the “best” value for the scoring) equals to 0.12 seconds, corresponding to an instantaneous perception threshold.

If a future input case falls outside the data range of the KPI, it will be set to the extreme value min_{KPI} (if it is worse) or max_{KPI} (if it is better).

3.8.2.1.1.2.4 KPIs Processing and Generalized MOS Use

The process can be described in the Figure here below.

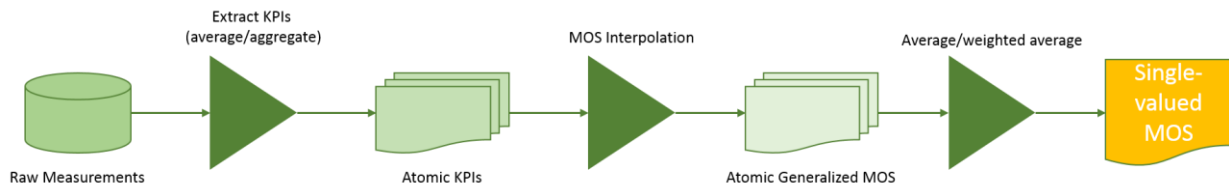

Figure 3.8.2-6 :- KPI Process and Generalized MOS USE

The tests will generate an amount of raw measurement data about several aspects of the system. Specific Atomic KPIs can be then extracted through averaging (or higher order statistical processing) rather than use of more complex formulations, depending on the type of measurement and its value type (e.g. difference between integer or bool types). The Atomic KPIs will be individually interpolated in order to provide a common, homogeneous comparison and aggregation space. The interpolation will create a Generalized MOS-type of values that will be further aggregated together through an averaging/weighted averaging process. This final stage will provide a single-valued MOS type that will describe the performance of the service for a certain Test Campaign.

3.8.2.1.1.2.5 API-based Service Quality Estimation

It is nowadays common for internet services to expose a public API to provide third parties with the possibility of developing their own clients or embed the services in other types of applications. An API is a set of function for controlling the service or used to provide information about the service itself. Some service provider provides direct access to measurements about the service quality through the API, while others simply give access to events happening during the service provision.

A very common example of the latter is in fact YouTube. Google provides, besides to the “intents” for controlling the streaming service (such as play, pause, stop), events related to e.g. buffering or re-buffering, loading or re-loading of a media frame at the beginning or after re-buffering. Through these events it is possible to extract measurements and provide a detailed profile of the service performance. This type of measurements is particularly suited for modern Content Streaming services that are HTTP-based, as pointed out in.

3.8.2.1.1.2.6 Atomic KPIs Summary

The first stage is planning the measurements that should be performed and how they link to the KPIs. For CS use case:

<i>Measurements</i>	Type	Unit	Summarization	KPI
<i>Access Time</i>	Unsigned Integer	n/a	Average, Deviation, CDF	App Access Time
<i>Accessibility</i>	Boolean	n/a	Ratio	App Accessibility
<i>Availability</i>	Boolean	n/a	Ratio	App Availability
<i>Time to load first media frame</i>	Unsigned Integer	s	Average, Deviation, CDF	Content Load Time
<i>Time to load after resuming</i>				
<i>Playback</i>	Boolean	n/a	Ratio	Feature Availability
<i>Pause Operation</i>				
<i>Resume Operation</i>				
<i>Stop Operation</i>				
<i>Rewind Operation</i>				
<i>Fast Forward Operation</i>				
<i>Search Operation</i>				
<i>Seek Operation</i>				
<i>Skip Forward Operation</i>				
<i>Skip Backward Operation</i>				
<i>{Picture, Video, Comment, File} Transfer</i>				
<i>Content Stall</i>	Vector of Unsigned Integer	s	Count, Index (1), CDF	Content Stall
<i>Search Time</i>	Unsigned Integer	s	Average, Deviation, CDF	Content Search Time
<i>Video Resolution</i>	Vector of Nominal	n/a	Mode, CDF	Content Resolution

Table 3.8-3 :- Planned measurements association to KPI for CS

3.8.2.1.2 Social Networking QoE

A good deed of the internet traffic is nowadays composed by Social Media and Social Networks. Such services are very varying in nature, since every provide offers slightly different sets of features. Depending on the type of Social Network, different measurements can be performed.

While some of the measurements resemble closely the ones made for the CS use case, we need to remember that for the SN use case the video streaming is designed in a much different way, providing multiple low quality videos for the user to browse through.

For this reason, a different type of testing and measurements are required. Most of the Social Networks have Available an API for testing that can be automated for performing service testing. In [21], the following Table 3.8-4 :- Proposed Atomic KPIs for the use SN Use Case has been proposed for the defining the Atomic KPIs for the SN use case.

<i>Measurements</i>	Type	Unit	Summarization	KPI
<i>Access Time</i>	Unsigned Integer	n/a	Average, Deviation, CDF	App Access Time
<i>Accessibility</i>	Boolean	n/a	Ratio	App Accessibility
<i>Availability</i>	Boolean	n/a	Ratio	App Availability
<i>Time to load first media frame</i>	Unsigned Integer	s	Average, Deviation, CDF	Content Load Time
<i>Time to load after resuming</i>				
<i>Playback</i>	Boolean	n/a	Ratio	Feature Availability
<i>Pause Operation</i>				
<i>Resume Operation</i>				
<i>Stop Operation</i>				
<i>Search Operation</i>				
<i>{Picture, Video, Comment, File} Transfer</i>				
<i>Content Stall</i>	Vector of Unsigned Integer	s	Count, Index (1), CDF	Content Stall
<i>Search Time</i>	Unsigned Integer	s	Average, Deviation, CDF	Content Search Time
<i>{Picture, Video, File} Download Time</i>	Unsigned Integer	s	Average, Deviation, CDF	Content Download Throughput
<i>{Picture, Video, File} Upload Time</i>	Unsigned Integer	s	Average, Deviation, CDF	Content Upload Throughput
<i>Video Resolution</i>	Vector of Nominal	n/a	Mode, CDF	Content Resolution

Table 3.8-4 :- Proposed Atomic KPIs for the use SN Use Case

3.8.2.1.3 High Speed Internet QoE

One of the most common applications for 5G will still be internet broadband access. While current internet speeds are somehow acceptable for existing services and websites, there is a continuous trend in making websites heavier and fancier.

In order to maintain a good quality of experience for the users and a low loading time it is required that internet access speed increases accordingly. The availability of the service with such speeds can be quite challenging in certain scenarios.

The number of applications and services that make use of high-speed internet is very extensive. However, it is commonly assumed that the "broadband everywhere" will provide a minimum of 20 Mbit/s "everywhere". Thus, this is the minimum throughput that services in this category are expected to cope with.

The typical applications within this category are the traditional browsing, online storage services such as Dropbox or OneDrive, FTP file transfer. Even in this Use Case the API-based automation and deduction of measurements can be used. The KPIs that can be derived for the HS use case are listed in the following table according to [21].

Measurements	Type	Unit	Summarization	KPI
<i>Access Time</i>	Unsigned Integer	n/a	Average, Deviation, CDF	App Access Time
<i>Accessibility</i>	Boolean	n/a	Ratio	App Accessibility
<i>Availability</i>	Boolean	n/a	Ratio	App Availability
<i>{Picture, Video, Comment, File} Transfer</i>	Boolean	n/a	Ratio	Feature Availability
<i>{Picture, Video, File} Download Time</i>	Unsigned Integer	s	Average, Deviation, CDF	Content Download Throughput
<i>{Picture, Video, File} Upload Time</i>	Unsigned Integer	s	Average, Deviation, CDF	Content Upload Throughput

Table 3.8-5 :- High Speed Use Case KPI

3.8.2.2 Test configuration

All deployment scenarios described in section 3.2 apply for the user experience tests.

Where indoor and max. 3km/h speed is specified, the user experience tests should be executed using walk test solutions on the move or stationary.

Where outdoor and speeds of 30km/h or higher are specified, the user experience tests should be executed using drive test equipment.

To be comparable to other tests (and to be as close to real world as possible), it is recommended to execute the "user experience" tests as drive/walk-tests also in the single cell, 7-cell cluster without traffic load and 7-cell cluster with traffic load/interference as indicated in section 3. This allows to measure the user experience during cell change / handover.

In LTE and other existing technologies, these tests are executed using a test SW integrated into commercial smartphones to really reflect the end user perception. For pre-commercial trials in 5G, this will rely certainly on early UE implementations coming from chipset suppliers. Therefore, a strong cooperation between the test solution and the early UE implementation is essential to execute these application tests for Quality of Experience in such an early phase.

The test cases should be pre-defined and scheduled in jobs to avoid mutual impact on the one hand but to allow for sufficient statistics on the other hand.

3.8.2.3 Test procedures

3.8.2.3.1 Test Procedure for Content Streaming

Service User Flows:

These are the most common user actions performed by the users in Content, on-demand, Streaming applications. Such Application User Flows will be the base for creating Test Cases and measuring relevant service KPIs. They make use of Reference Videos (RVx) or of commercially available video services. They make use of reference video channels LCy. or of commercially available video services.

<i>Use Case</i>	Application User Flow
CS	Play three reference videos: Perform login step and wait for 10 seconds. Play sequentially the three reference videos RV1, RV2 and RV3 from a live streaming platform or from an on-demand platform or Play a preselected live video streaming content from a commercial video service. Measure the video quality (time to first picture, freezing/stalling, jerkiness, picture quality in terms of Video MOS)
CS	Play and pause (does not apply to live streaming test) Perform login step and wait for 10 seconds. Start playing RV3 during 10 seconds. Pause the reproduction. Resume the reproduction after 2 minutes
CS	Rewind and Fast Forward (does not apply to live streaming test) Perform login step and wait for 10 seconds. Start playing RV3 for 10 seconds. Perform fast forward during 2 minutes (select X8 speed if supported by the App, else select the highest speed supported). Change to normal play and keep this mode for 10 seconds. Perform rewind for 2 minutes (select X8 speed if supported by the App, else select the highest rewind speed supported), Stop the playback.
CS	Download a media file Perform login step and wait for 10 seconds. Download RV3. Wait until the download is complete.
CS	Set background state. Perform login step and wait for 10 seconds. Set the App in background state. Wait for 20 minutes Set the App in active state
CS	Play and Stop (does not apply to live streaming test) Perform login step and wait for 10 seconds. Start playing RV3. Stop the reproduction after 1 minute. Resume the reproduction after 1 minutes
CS	Search and Seek (does not apply to live streaming test)

	Perform login step and wait for 10 seconds. Search reference file RV3. Start playing RV3. Seek the player at 15 minutes' position.
CS	Search and Change Channel (applies to live streaming test) Perform login step and wait for 10 seconds. Play reference live channel LC1. Search for reference live channel LC2 Change to live channel LC2.
CS	Skip forward and backward (does not apply to live streaming test) Perform login step and wait for 10 seconds. Start playing RV2. After 1 minute, skip backward to the beginning of the media file. After 20 seconds, skip forward to the next media file (RV3). After 5 seconds, skip backward to the previous media file (RV2).

Table 3.8-6 :- Streaming Application User Process flow

3.8.2.3.2 Social Networking QoE

These are the most common user actions performed by the users in Social Networking applications. Such Application User Flows will be the base for creating Test Cases and measuring relevant service KPIs. Obviously not all of the User Flows are applicable to all the Social Networks. A feature applicability table is required. The User Flows make use of reference videos (RVx), reference comments (RCy), and reference pictures (RPz).

<i>Use Case</i>	Application User Flow
SN	Post comments Perform login step and wait for 10 seconds. Post reference comment: RC1. Post reference comment: RC2. Post reference comment: RC3.
SN	Post pictures Perform login step and wait for 10 seconds. Post sequentially the pictures: RP1, RP2 and RP3 and without any delay between the pictures. Wait until the last picture is completely uploaded.
SN	Post videos Perform login step and wait for 10 seconds. Post sequentially the pictures: RV1, RV2 and RV3 and without any delay between videos. Wait until the last video is completely uploaded.
SN	Post live video Perform login step and wait for 10 seconds. Post sequentially the pictures: RV1, RV2 and RV3 and without any delay between videos. Wait until the last video is completely uploaded.
SN	Post location Perform login step and wait for 10 seconds. Post sequentially the reference location: RL1.
SN	Post files Perform login step and wait for 10 seconds. Post sequentially the reference files: RF1, RF2 and RF3. Wait until all the files are completely uploaded.

<i>SN</i>	Get comment Perform login step and wait for 10 seconds. Get the first available comment.
<i>SN</i>	Show picture Perform login step and wait for 10 seconds. Get the first available picture.
<i>SN</i>	Play video Perform login step and wait for 10 seconds. Get the first available video.
<i>SN</i>	Play live video Perform login step and wait for 10 seconds. Get reference live video
<i>SN</i>	Get file Perform login step and wait for 10 seconds. Get the first available file.
<i>SN</i>	Search objects Perform login step and wait for 10 seconds. Search the most relevant item for which the App has been mainly designed (e.g., contacts, flights, hotels, etc.).

Table 3.8-7 :- Social Networking Application User Flow

3.8.2.3.3 High Speed Internet QoE

These are the most common user actions performed by the users in High Speed Internet applications, as evaluated in [21]. Such Application User Flows will be the base for creating Test Cases and measuring relevant service KPIs. Obviously not all the User Flows are applicable to all the possible High Speed Internet applications. A feature applicability table is required. The User Flows make use of reference files (RFx).

<i>Use Case</i>	Application User Flow
<i>HS</i>	Download three files sequentially Perform login step and wait for 10 seconds. Download sequentially the reference files: RF1, RF2 and RF3 and without any delay between them. Wait until the last file is completely downloaded.
<i>HS</i>	Upload three files sequentially Perform login step and wait for 10 seconds. Upload sequentially the reference files: RF1, RF2 and RF3 and without any delay between them. Wait until the last file is completely uploaded.
<i>HS</i>	Download several files simultaneously Perform login step and wait for 10 seconds. Download simultaneously the reference files: RF1, RF2, RF3, RF4, RF5 and RF6. Wait until the last file is completely downloaded.
<i>HS</i>	Upload several files sequentially Perform login step and wait for 10 seconds. Upload simultaneously the reference files: RF1, RF2, RF3, RF4, RF5 and RF6. Wait until the last file is completely uploaded.
<i>HS</i>	Download a huge file Perform login step and wait for 5 seconds. Download the reference file RF7. Wait until the file is completely downloaded.
<i>HS</i>	Upload a huge file

	Perform login step and wait for 5 seconds. Upload the reference file RF7. Wait until the last file is completely uploaded.
HS	Pause and Resume Download Perform login step and wait for 10 seconds. Start downloading the reference file RF7. After 30 seconds, pause the file transfer. Wait for 15 seconds and resume the transfer
HS	Pause and Resume Upload Perform login step and wait for 10 seconds. Start uploading the reference file RF7. After 30 seconds, pause the file transfer. Wait for 15 seconds and resume the file upload.

Table 3.8-8 :- High Speed Application User Flow

3.8.3 Success criteria

The target is to map the test results described in section 3.8.2 geographically and to log the technologies (5G carrier or fallback to LTE in NSA (non stand-alone) mode) and other radio parameters as well. The behavior in case of handovers between cells in the cluster and between technologies is interesting in particular.

Pass/fail criteria for voice/video services and in particular for social media and high speed internet browsing cannot be easily determined. In fact, for these applications the pass/fail also depends on user perception whether a certain waiting time is acceptable or not.

3.8.3.1 CS

Following the flow of a typical video service measurement at service level in the definition chapter the relevant KPIs for Content Streaming for the ITU-based method are the following:

KPI	Target	Function		
			min _{KPI}	max _{KPI}
App/Server Accessibility (%)	Ratio	Type I	50	100
Content Load Time / time to first picture (s)	Average	Type II	10	0.1
Content Stall/Freeze (%)	Index	Type I	10	0
Jerkiness (%)	Index	Type I	20	0
Video Quality MOS for 10s intervals and for whole video / session	Average	MOS according to ITU	n.a.	n.a.

Table 3.8-9 :- Content Streaming for the ITU-based method

In case of the “Generalized method” the second step is how the different KPIs can be interpolated into a Generalized MOS:

KPI	Target	Function		
			min _{KPI}	max _{KPI}
App Access Time (s)	Average	Type II	10	0.1

<i>App Accessibility (%)</i>	Ratio	Type I	50	100
<i>App Availability (%)</i>	Ratio	Type I	50	100
<i>Content Load Time (s)</i>	Average	Type II	10	0.1
<i>Feature Availability (%)</i>	Ratio	Type I	50	100
<i>Content Stall (%)</i>	Index	Type I	5	0
<i>Content Search Time (s)</i>	Average	Type II	10	0.1
<i>Content Resolution</i>	Mode	Type I	Lowest	Highest
<i>Video Quality MOS</i>	Average	n.a.	n.a.	n.a.

Table 3.8-10 :- Content Streaming KPIs interpolation into Generalized MOS

3.8.3.2 SN

In case of the “Generalized method” the second step is how the different KPIs can be interpolated into a Generalized MOS:

KPI	Target	Function		
			\min_{KPI}	\max_{KPI}
<i>App Access Time (s)</i>	Average	Type II	10	0.1
<i>App Accessibility (%)</i>	Ratio	Type I	50	100
<i>App Availability (%)</i>	Ratio	Type I	50	100
<i>Content Load Time (s)</i>	Average	Type II	10	0.1
<i>Feature Availability (%)</i>	Ratio	Type I	50	100
<i>Content Stall (%)</i>	Index	Type I	5	0
<i>Content Search Time (s)</i>	Average	Type II	10	0.1
<i>Content Download Throughput (Mbit/s)</i>	Average	Type I	1	1000
<i>Content Upload Throughput (Mbit/s)</i>	Average	Type I	1	1000
<i>Content Resolution</i>	Mode	Type I	Lowest	Highest

Table 3.8-11 :- Social Network KPI Interpolation into a Generalized MOS

3.8.3.3 HS

In case of the “Generalized method” the second step is how the different KPIs can be interpolated into a Generalized MOS:

KPI	Target	Function		
			min_{KPI}	max_{KPI}
<i>App Access Time (s)</i>	Average	Type II	10	0.1
<i>App Accessibility (%)</i>	Ratio	Type I	50	100
<i>App Availability (%)</i>	Ratio	Type I	50	100
<i>Feature Availability (%)</i>	Ratio	Type I	50	100
<i>Content Download Throughput (Mbit/s)</i>	Average	Type I	1	1000
<i>Content Upload Throughput (Mbit/s)</i>	Average	Type I	1	1000

Table 3.8-12 :- High Speed KPIs Interpolation into Generalized MOS

3.9 Energy efficiency

This section should consider energy efficiency both at the network as well as the device side.

Reminder of Energy Efficiency Requirement as per the NGMN 5G White paper [1]:

- “Energy efficiency is defined as the number of bits that can be transmitted per Joule of energy, where the energy is computed over the whole network, including potentially legacy cellular technologies, Radio access and Core networks, and data centres.
- 5G should support a 1,000 times traffic increase in the next 10 years’ timeframe, with an energy consumption by the whole network of only half that typically consumed by today’s networks. This leads to the requirement of an energy efficiency increase of x2000 in the next 10 years’ timeframe.
- Every effort should be made to obtain the energy efficiency gain without degrading the performance, but the technology should allow native flexibility for the operator to configure trade-off between energy efficiency versus performance where justified.”

3.9.1 UE energy efficiency

3.9.1.1 Definition

UE energy efficiency refers to the capability of a UE to support a typical set of daily use cases for a given energy consumption. The typical daily use cases comprise of a UE in active use (transferring data using mobile broadband data, voice call, etc.) as well as the UE in standby scenarios. It is equally important for the UE to be energy efficient while transferring data as it is for the UE to be efficient while in a standby mode. Energy efficiency directly impacts the UE battery life and has a significant bearing on the user experience by determining the Day of Use (DOU) metric for the User Equipment.

It is a qualitative KPI where the evaluation methodology should be based on inspection. More detailed quantitative assessment can also be performed.

3.9.1.2 Test Environment

3.9.1.2.1 Test setup

Scenario 1: UE configured to operate in NSA mode of operation. UE operates in a dual connectivity mode with LTE.

- 1a: UE is placed in a test location corresponding to good coverage.
- 1b: UE is placed in a test location corresponding to poor coverage.

Scenario 2: UE configured to operate in Stand Alone (SA) mode of operation.

- 2a: UE is placed in a test location corresponding to good coverage.
- 2b: UE is placed in a test location corresponding to poor coverage.

3.9.1.2.2 Test Configuration

All deployment setups in section 2.2 should be considered.

Configuration 1: NR in Sub 6GHz, eMBB service configured

- 100MHz component carrier, 1 component carrier
- 30kHz subcarrier spacing
- Slot duration: 500us

Configuration 2: NR in mmW band. eMBB service configured

- 100MHz component carrier, 8 component carriers
- 120kHz subcarrier spacing
- Slot duration: 125us

Configuration 3: NR in Sub 6GHz. URLLC service configured

- 100MHz component carrier, 1 component carrier
- 30kHz subcarrier spacing
- Slot duration: 500us

3.9.1.2.3 *Test Procedures*

3.9.1.2.3.1 **Data download using eMBB Service**

1. Configure the UE to download a test file of known size (X^{10} MB).
2. After the download is complete, allow the UE to go to inactive mode
3. Repeat step 1 and 2. Repeat the procedure 20 times.
4. Measure the total energy consumed and compute the average per MB of data transfer

3.9.1.2.3.2 **URLLC service**

1. Register the UE to receive a URLLC service from the network.
2. Configure a URLLC data packet to UE from the network every $X1^{11}$ seconds.
3. Perform the test over a total duration of $X2^{12}$ minutes.
4. Measure the total energy consumed by the UE during the total duration of the test.

3.9.1.2.4 *Success criteria*

The energy efficiency improvement from 5G NR at the UE side is recommended to be at least an order of magnitude better than LTE.

3.9.2 **Network energy efficiency**

3.9.2.1 **Definition**

Network energy efficiency shall be considered as a basic principle in the NR design. The target is a design with the ability to:

- efficiently deliver data, and
- provide sufficiently granular network discontinuous transmission when there is no data to transmit and network availability is maintained
- to provide operator flexibility to adapt sleep durations of base stations depending on load, services and area

Network Energy Efficiency KPI (in bits per Joule) defined in [22] shall be used to:

- evaluate the energy consumption at different traffic levels.
- compare different solutions or mechanisms directly related to energy efficiency (ex: energy saving features),
- compare the final NR system design with LTE to evaluate the overall improvement brought in terms of Network EE

Definition:

¹⁰ Several file sizes should be considered.

¹¹ Several packet frequencies should be considered.

¹² This time should be enough to get statistically meaningful results (depends on the packet frequency).

$$EE_{global} = \sum_K EE_K \quad (3.9-1)$$

K : refers to the number of activated base stations

$$EE_{BTS} = \sum_{load\ level\ 1} \frac{V_1}{EC_1} \quad (3.9-2)$$

V_1 = Refers to the traffic volume delivered by the base station during 15min (in bits) for different loads

EC_1 = Refers to the energy consumed by a base station to during 15 min (in Wh or Joules).

3.9.2.2 Test setup

Configuration

For sake of comparison, the following characteristics shall be precisely described for each base station:

- Number of baseband and radio (RF modules, active antennas)
- Number of carriers
- Configured output power (ex: 2x40W, 2x80W, 4x40W, 64x3.125W, ...)
- Number of Tx/Rx per radio module / active antenna (ex: 2T2R, 4T4R, 64T64R, ...)
- Frequency band (ex: 3400-3600MHz, 24.25-27.5GHz, 700MHz, ...)
- Configured bandwidth (ex: 10MHz, 20MHz, 100MHz, 500MHz, 800MHz, ...)

Traffic & energy counters

The system shall be able to measure the traffic data volume and the energy consumption with a 15 min granularity (or 1hour as a back-up)

- Traffic data volume (downlink & uplink): based on RAN OSS counters
- Energy consumption per RAN equipment (BBU, RF module, active antenna)
 - based on OSS counters (if energy probes are embedded in RAN equipment as described in [23])
 - or based on external energy probes

Real traffic generation

Real traffic will be generated by UEs used for tests during trial, which will impact RAN power consumption.

Radio load generation (applicable to RAN)

Radio load can be simulated by RAN internal system: 0%, 10%, 30%, 50% and 100%.

For instance, the following load generation mechanisms can be used for legacy technologies (2G/3G/4G)

- For 3G/4G: the OCNS method can be used (Orthogonal Channel Noise Simulator, a noise generator method).
- For 2G: timeslot usage shall be used according the traffic model provided by ETSI standard [23].
- Measurement duration: 2 minutes per load level

Similar load generation methods shall be used for 5G either by RAN internal system or any other solution compliant to [23])

Energy Savings Features

Measurements shall be performed in a first step without any energy savings features to evaluate basic RAN power consumption (baseline).

In a second step, energy savings features (advanced sleep modes, carrier/MIMO switch off, PA bias adaptation, etc...) can be activated to evaluate additional energy savings compared to baseline.

Technical environment

ngmn e. V.

Großer Hasenpfad 30 • 60598 Frankfurt • Germany

Phone +49 69/9 07 49 98-04 • Fax +49 69/9 07 49 98-41

The measurement shall be performed at BTS equipment level and taking into account only the radio equipment (meaning: digital baseband board & power amplifiers). All other equipment excluded (rectifiers, cooling, PSU, batteries ...)

Temperature

As temperature can impact power consumption, temperature evolution shall be monitored during trial:

- Based on dedicated temperature probes
- Or based on meteorology web sites (ex: accuweather) if probe is not available

3.9.2.3 Success criteria

Expected output with Real traffic generation (applicable to all network equipment)

Energy efficiency based on traffic volume is calculated according to formula described in section 3.9.2.1

$$\text{Power efficiency (traffic volume)} = \text{traffic volume (bits)} / \text{power consumption (W)}$$

As energy efficiency will vary depending on traffic, different timeslots can be defined in output table depending on traffic volume generated by tests on trial area (to be adapted depending on test activities)

Example below is provided for RAN. Same methodology can be applied to all network equipment.

base station reference	BTS / BBU / RU / AAU 1					BTS / BBU / RU / AAU 2				
	Timeslot	2-3am	10-11am	2-3am	10-11am
Data volume (Mbits)	100Mbits	10Gbits	150Mbits	15Gbits
Configured radio output power	80W (2x40W)					200W (64x3.215W)				
Power consumption (W)	140	180	250	320
Energy efficiency (traffic volume)	198bit/J	15432bits/J	166bit/J	13020bits/J

Table 3.9-1 :- RAN Energy Efficiency Measurement results

Expected output with Radio load generation (applicable to RAN)

Energy efficiency based on load is calculated based on the following formula (no traffic volume counters available).

$$\text{Energy efficiency (load)} = (\text{Configured radio output power} \times \text{radio load}) / \text{power consumption.}$$

Example of table output table is provided below:

base station reference	BTS / BBU / RU / AAU 1					BTS / BBU / RU / AAU 2				
	Radio load	0%	10%	30%	50%	100%	0%	10%	30%	50%
Configured radio output power	80W (2x40W)					200W (64x3.215W)				
Power consumption (W)	100	150	180	200	250	200	300	350	400	500
Energy efficiency (load)	0%	5%	13%	20%	32%	0%	7%	17%	25%	40%

Table 3.9-2 :- RAN Output Measurements

Energy efficiency based on load is applicable to RAN equipment (AAU, RU, baseband)

Energy savings features

ngmn e. V.

Großer Hasenpfad 30 • 60598 Frankfurt • Germany

Phone +49 69/9 07 49 98-04 • Fax +49 69/9 07 49 98-41



When applicable, similar tables shall be provided before and after activation of energy savings features to evaluate their impact on energy efficiency.

Comparison with 4G

When applicable (4G & 5G collocated sites), similar tables shall be provided for 4G for sake of comparison between 5G and 4G.

3.10 Inter-RAT procedures

This section presents the inter-RAT mobility trial requirement between 5G NR network and legacy networks especially LTE. Only packet switched data scenarios are considered.

Test scenarios are classified into 2 groups: SA (Standalone) and NSA (Non-Standalone).

3.10.1 NSA Inter-RAT Mobility with PS Service

IRAT mobility is classified into two categories:

1. Terminal device idle mode cell reselection
2. Terminal device active mode IRAT handover

3.10.1.1 NSA Inter-RAT Cell Reselection

From [11], In MR-DC, the SN is not required to broadcast system information other than for radio frame timing and SFN. System information for initial configuration is provided to the UE by dedicated RRC signaling via the MN. In NSA configuration, UE is camped on Master LTE eNB that is why cell reselection is not applicable here.

3.10.1.2 NSA Inter-RAT Mobility

3.10.1.2.1 Definition

This section focuses on testing MR-DC cases with LTE eNB as Master Node and 5G NR gNB as Secondary Node in NSA Configuration.

As mentioned in [11], for NSA MR-DC with the EPC configuration is as follows.

E-UTRAN supports MR-DC via E-UTRA-NR Dual Connectivity (EN-DC), in which a UE is connected to one eNB that acts as a MN and one gNB that acts as a SN. The eNB is connected to the EPC and the gNB is connected to the eNB via the X2 interface.

Therefore, for NSA case, because of MR-DC handover will not take place during mobility. As a consequence, Secondary Node Addition and Release scenarios are considered here.

3.10.1.2.2 Test Environment

3.10.1.2.2.1 Test Setup

Deployment scenario: Rural, Urban, Dense urban

One Master LTE cell and one 5G NR cell in order to trigger secondary cell addition/release during drive test.

3.10.1.2.2.2 Test Configuration

The tests should be performed for all the configurations mentioned in Table 3.10-1 :- Mobility trial configuration below.

Speed ranges	0-15km/h	15-60 km/h	60-120 km/h	120-500 km/h
TCP	Config 1	Config 3	Config 5	Config 7
UDP	Config 2	Config 4	Config 6	Config 8

Table 3.10-1 :- Mobility trial configuration

For each configuration in table 3.10-1, below scenarios shall be considered:

- Scenario 1: MR-DC, Secondary Node Addition (Figure 3.10-1 :- Secondary Node Addition). ([11] sec10.2)

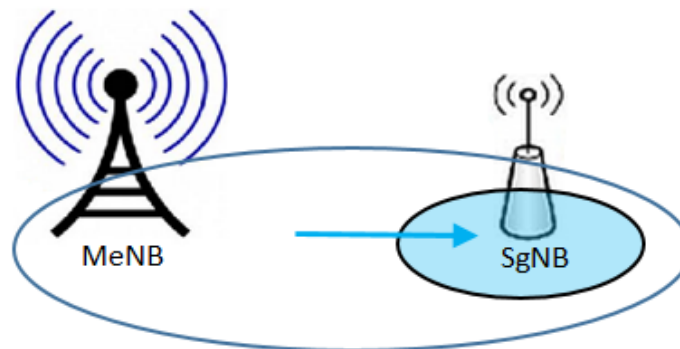

Figure 3.10-1 :- Secondary Node Addition

- Scenario 2: MR-DC, Secondary Node Release (Figure 3.10-2 :- Secondary Node Release) ([11] sec10.4)

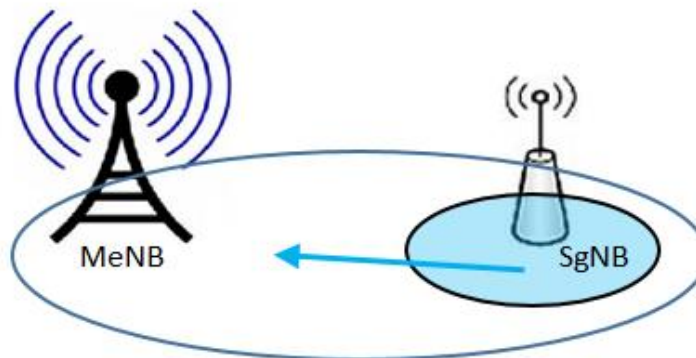

Figure 3.10-2 :- Secondary Node Release

3.10.1.2.2.3 Test Procedure

1. LTE and 5G NR Base Stations are powered on and configured with MR-DC related parameters (thresholds etc...)
2. All the UEs are under MeNB LTE cell coverage, no 5G NR cell coverage.
3. UEs are powered on and complete initialization process.
4. UEs are successfully attached to the LTE and are able to upload/download data.
5. All UEs start uploading/downloading data (e.g. from an FTP server)
6. UEs should move from current position to 5G NR cell coverage area as in figure 3.10-1.
7. Be sure that secondary cell addition procedure is successfully performed for all UEs and UEs are in MR-DC mode and can upload/download data from 5G NR cell.
8. UEs should move from 5G NR cell coverage area to no 5G NR coverage area as in figure 3.10-2.
9. Be sure that secondary cell release procedure is successfully performed for all UEs and UEs are only getting service from LTE and can upload/download data only from LTE cell.

3.10.1.2.3 Success Criteria

Minimum 20 valid samples are required for result evaluation.

ngmn e. V.

Großer Hasenpfad 30 • 60598 Frankfurt • Germany

Phone +49 69/9 07 49 98-04 • Fax +49 69/9 07 49 98-41

- DL and UL Throughput:
DL/UL Throughput variations and Minimum DL/UL throughputs during secondary cell addition/release at different speeds should be continuously monitored.
- Packet loss:
it is necessary to report precisely in which layer the packet loss is measured in the trial:
 - At network layer (layer 3 in OSI model)
IP Packet Loss Rate (IP PLR)
 - At transport layer (layer 4 in OSI model)
TCP PLR or UDP PLR (equal to IP PLR)
 - At application layer (layer 5 in OSI model)
Frame erasure rate (FER) to evaluate the information loss
No additional packet loss is expected during secondary cell addition/release operations.
- Interruption time:
No interruption time is expected during secondary cell addition/release operations.

3.10.2 SA Inter-RAT Mobility with PS Service

IRAT mobility is divided into two categories:

- 1) Terminal device idle mode cell reselection
- 2) Terminal device active mode IRAT handover

3.10.2.1 SA InterRAT Cell Reselection

3.10.2.1.1 Definition

IRAT cell re-selection from 5G NR to LTE or from LTE to 5G NR.

3.10.2.1.2 Test Environment

3.10.2.1.2.1 Test Setup

Deployment scenario: Rural (section 3.2.4), Urban (section 3.2.3), Dense urban (section 3.2.2).
One 5G NR cell and one LTE cell in order to trigger cell reselection during drive test.

3.10.2.1.2.2 Test Configuration

Two configurations should be tested:

Scenario	Terminal camped on 5G NR cell can reselect to a legacy cell	Terminal camped on legacy cell can reselect to a 5G NR cell
Configuration	Configuration 1	Configuration 2

Table 3.10-2 :- Cell reselection trial configuration

In scenario 1, Cell 1 is 5G NR and Cell 2 is LTE while in scenario 2 opposite is the case.

3.10.2.1.2.3 Test Procedure

1. LTE and 5G NR Base Stations are powered on and configured with cell reselection related parameters (priority, thresholds etc...)
2. All the UEs are under Cell 1 coverage.
3. UEs are powered on and complete initialization process.
4. UE's are successfully attached to the LTE or 5G network according to the tested scenario.
5. All UEs are in idle mode.
6. UE should move from Cell 1 to Cell 2.
7. Be sure that cell reselection procedure is successfully performed for all UEs and UEs are attached to other technology without any problem.

3.10.2.1.3 **Success Criteria**

Terminal device is able to reselect a cell that belongs to another RAT.
Cell reselection time between RATs should be measured.

3.10.2.2 **SA Inter-RAT Handover**

This section focuses on testing handover from 5G NR to LTE and handover from LTE to 5G NR with active PS service in SA configuration.

3.10.2.2.1 **Definition**

Handover from 5G NR to LTE and from LTE to 5G NR scenarios are considered here.

3.10.2.2.2 **Test Environment**

3.10.2.2.2.1 **Test Setup**

At least one LTE eNB and one Secondary 5G NR gNB is needed in order to setup below scenarios.
It is better to setup a cluster with more LTE/ 5G NR cells.

Below KPI's should be focused on during the test:

- Handover interruption time which is defined in NGMN 5G Whitepaper 6 as a time during which the user is not able to receive any user plane data, including inter-system authentication time, should be evaluated in different scenarios and configurations.
- DL and UL throughput variations and minimum DL/UL Throughput should be measured and verified during inter-RAT handover
- Number of packets loss due to handover procedure should be measured during trial.

3.10.2.2.2.2 **Test Configuration**

The tests should be performed for all the configurations mentioned in Table 3.10-3 :- Handover trial configuration below.

Speed ranges	0-15km/h	15-60 km/h	60-120 km/h	120-500 km/h
TCP	Config 1	Config 3	Config 5	Config 7
UDP	Config 2	Config 4	Config 6	Config 8

Table 3.10-3 :- Handover trial configuration

For each configuration in table 3.10-3, below scenarios shall be considered:

- From 5G NR cell to LTE Cell
- From LTE cell to 5G NR

Cell 1 is 5G NR and Cell 2 is LTE in scenario 1 and vice versa in scenario 2.

3.10.2.2.2.3 Test Procedure

1. LTE and 5G NR Base Stations are powered on and configured with handover related parameters (neighbor cells, thresholds etc...)
2. All the UEs are under Cell 1 coverage.
3. UEs are powered on and complete initialization process.
4. UEs are successfully attached to the LTE or 5G network according to the tested scenario and are able to upload/download data.
5. All UEs start uploading/downloading data (e.g. from an FTP server)
6. For all scenarios above (scenario 1 to 2), UEs should move from Cell 1 to Cell 2 with velocities given in table 5.6-2.
7. Be sure that handover procedure is successfully performed for all UEs.

3.10.2.2.3 Success Criteria

Minimum 20 valid samples are required for result evaluation.

- DL and UL Throughput:
DL/UL Throughput variations and Minimum DL/UL throughputs during handover at different speeds should be continuously monitored.
- Packet loss:
it is necessary to report precisely in which layer the packet loss is measured in the trial:
 - At network layer (layer 3 in OSI model)
IP Packet Loss Rate (IP PLR)
 - At transport layer (layer 4 in OSI model)
TCP PLR or UDP PLR (equal to IP PLR)
 - At application layer (layer 5 in OSI model)
Frame erasure rate (FER) to evaluate the information loss
- Interruption time:
The recommendation for user plane handover interruption time is to be 10 times better than LTE (200 msec).

3.11 RAN architecture split

5G RAN logical architecture for NR is currently highly debated within 3GPP and its decision will have a major impact on all future mobile communication networks. There are in principle two aspects of RAN architectural split: split between central unit (CU) and distributed unit (DU) and split between control plane (CP) and user plane (UP). 3GPP is expected to study 8 different functional splits between CU/DU. In addition, it is recognized that it may be favorable and beneficial for **ngmn e. V.**

the next generation RAT, to base the architecture on a separation of the CP and UP functions. This separation would imply to allocate specific CP and UP functions between different nodes [25].

3.11.1 CU-DU Separation

Some of the benefits of an architecture with the deployment flexibility to split and move NR functions between central and distributed units are below [25]:

- Flexible HW implementations allows scalable cost effective solutions.
- A split architecture (between central and distributed units) allows for coordination for performance features, load management, real-time performance optimization, and enables NFV/SDN.
- Configurable functional splits enable adaptation to various use cases, such as variable latency on transport.

The choice of how to split NR functions in the architecture depends on some factors related to radio network deployment scenarios, constraints and intended supported services. Some examples of such factors are:

- Need to support specific QoS settings per offered services (e.g. low latency, high throughput)
- Need to support specific user density and load demand per given geographical area (which may influence the level of RAN coordination)
- Need to be able to function with transport networks with different performance levels, from ideal to non-ideal

The NR design should support the flexibility to move RAN functions between the central unit and distributed unit depending on the factors above, and should be studied.

3.11.1.1 Definition

The following functional splits between central and distributed unit are possible, as illustrated in Figure 3.11-1 :- Function Split between central and distributed unit [25].

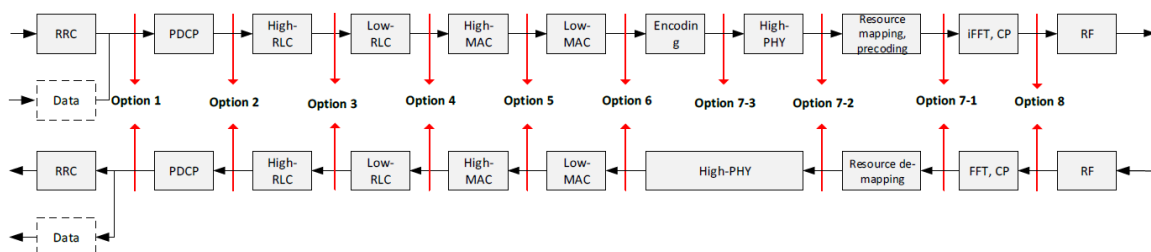

Figure 3.11-1 :- Function Split between central and distributed unit

3.11.1.1.1 Higher layer split

For the specification work, there shall be a single higher layer split option selected. In the meantime, if other decisions cannot be made, 3GPP RAN3 recommends to progress on Option 2 for high layer RAN architecture split. Depending on the final 3GPP decision, NGMN TTI pre-commercial trial work on this subject might need to be adjusted accordingly, to follow the specification effort.

In the Option 2 (3C-like split), the function split in this option is similar as 3C architecture in DC. It assumes that RRC and PDCP are in the central unit (CU). RLC, MAC, physical layer and RF are in the distributed unit (DU).

3.11.1.2 Test setup

High-level test set-up architecture is supposed to reflect currently discussed 3GPP architecture [26], which consists of a CU connected to one or multiple distributed units, as illustrated in Figure 3.11-2. One device per DU could be the baseline unless differently specified.

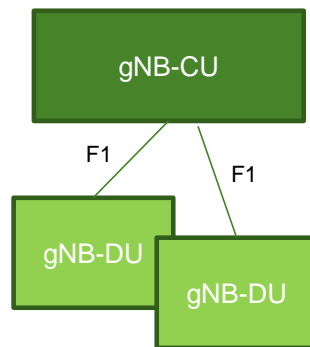

Figure 3.11-2 - gNB overall architecture

3.11.1.3 Configuration and test scenarios for higher layer split

The following test cases are meant to demonstrate the CU-DU separation. Option 2 is considered as the preferred higher layer functional split of 5G RAN architecture (RRC and PDCP are in the CU).

3GPP CU-DU split architecture implementation should be deployed in a multi-vendor fashion (see Figure 3.11-3).

- 1 CU implemented by vendor 1,
- 2 DUs by vendor 2,
- Support of open F1 interface.

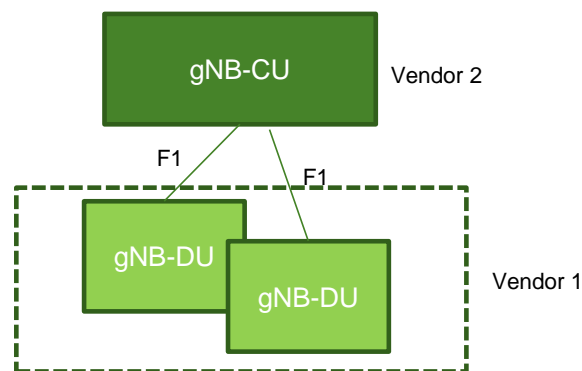

Figure 3.11-3 - CU/DU multi-vendor configuration

3.11.1.3.1 Test cases/scenarios

The following features/capabilities should be implemented and tested (test cases):

- UE handling (attach/detach)
- Connection Mobility (Intra-DU mobility, Intra-CU Inter-DU mobility)
- Implementation of radio features (e.g. DC)
- Data transport over PUSCH/PDSCH (cell peak rate, UE peak rate)
- Latency
- Fronthaul characteristics
- Operation procedures (Cell set-up/delete)

3.11.1.3.2 Success criteria

ngmn e. V.

Großer Hasenpfad 30 • 60598 Frankfurt • Germany

Phone +49 69/9 07 49 98-04 • Fax +49 69/9 07 49 98-41

Performance should be benchmarked against single vendor implementation of CU-DU split.

3.11.1.4 Configuration and test scenarios for low layer split

The following test cases are meant to demonstrate the CU-DU separation. Option 7-x is considered as the preferred higher layer functional split of 5G RAN architecture.

3GPP CU-DU split architecture implementation should be deployed in a multi-vendor fashion (see Figure 3.11-3).

- 1 CU implemented by vendor 1,
- 2 DUs by vendor 2,
- Support of open F1 interface.

3.11.1.4.1 Test cases/scenarios

Following features/capabilities should be implemented and tested (test cases):

- UE handling (attach/detach)
- Connection Mobility (Intra-DU mobility, Intra-CU Inter-DU mobility)
- Implementation of radio features (e.g. DC)
- Data transport over PUSCH/PDSCH (cell peak rate, UE peak rate)
- Latency
- Fronthaul characteristics (focused to test reduced bandwidth requirements on FH)
- Implementation of advanced receivers for UL (e.g. MMSE)
- Implementation of centralized scheduling for DL (e.g. coordinated scheduling)
- Operation procedures (Cell set-up/delete)

3.11.1.4.2 Success criteria

Performance should be benchmarked against single vendor implementation of CU-DU split.

3.11.2 CP-UP Separation

Separation of Control Plane (CP) and User Plane (UP) has gained some traction within the design of 5G Radio access to point that 3GPP start investigating such separation of functionalities [25] along with the architectural split between a centralized unit (CU) and Distributed Units (DUs).

The expected benefits of CP-UP separation, which need to be demonstrated, can be summarized as follows:

- A centralization of CP functions (at the CU) controlling different transmission points (at the DU's), which would achieve better radio performance thanks to a common implementation of multi-connectivity, joint transmission/reception, interference coordination and user mobility handling.
- Flexibility to operate and manage complex networks as simply as possible
- Allowing rapid adaptation to different network topologies, resources and new service requirements.
- Alignment with SDN concept that would result in a functional decomposition of the radio access and its programmability, based on a de-coupled architecture between user and control planes.
- Support for network slicing concepts that also involve functional decomposition of access network functions enabling an adaptation of specific functions depending upon network slice.
- Independent scaling and processor platform selection for control and user plane function operation.
- Support of multi-vendor interoperability where a CU is interoperable with different DU implementations.
- The disaggregated gNB deployment with separate CU-CP and CU-UP provides the possibility of optimizing the location of different RAN functions based on the scenario and desired performance.

Objective of the trials and test initiative would be that demonstrating functional decomposition of control plane and user plane functionalities by way of open interfaces and proving the benefits of centralized RRM functionalities in a CU-DU deployment.

3.11.2.1 Definition

High-level architecture is supposed to reflect currently discussed 3GPP architecture [26], which consists of a CU connected to one or multiple distributed units (e.g. 2-3), as illustrated in Figure 3.11.2-4. The reference CU-DU functional split is the higher layer one (i.e. PDCP split). One device per DU could be the baseline unless differently specified.

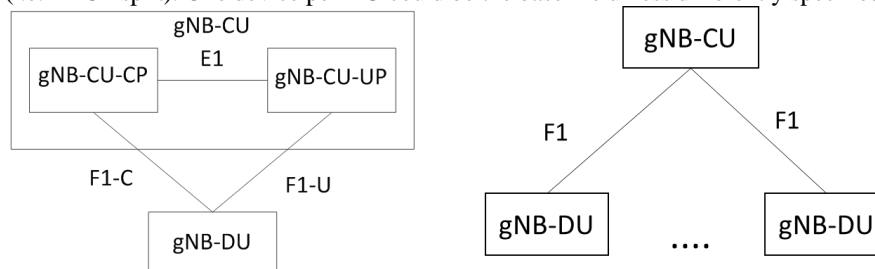

Figure 3.11.2-4 gNB architecture

Additionally, external controllers can be considered as a logical entity being connected via an open interface to the 3GPP reference architecture, for both disaggregated deployment (e.g. CU-DU split) and collapsed monolithic gNB. Interface between the external controller, which orchestrates part of radio CP functionalities, and the 3GPP logical node can be referred to as Southbound Interface. The controller can potentially support a Northbound interface which would allow interaction and e2e optimizations with inter-domain orchestrators in a virtualized environment.

3.11.2.2 Configuration and test scenarios

The following test cases are meant to demonstrate the CP-UP separation. Those are grouped based on reference architecture and its open interface along with the supported CP functionality.

- **Test Case 1: Basic central RRM functionality in CP-UP split**
 - 3GPP CU-DU split architecture and further separation of CU-CP vs. CU-UP within the CU
 - 1 CU-CP implemented by vendor 1,
 - 1 CU-UP and 2 DUs by vendor 2.
 - Support of open interfaces F1 (-C and -U) and E1.
 - Basic “delay-tolerant” centralized CP functionality:
 - Bearer and QoS flows management
 - Radio admission control
 - Connection Mobility Control (e.g. Inter-DU)
 - SON-functionality such as load balancing.
 - Activation and handling of radio features (e.g. CA, DC).
 - **Impact of interface transport layer performance** (delay, bandwidth) on overall performance.
- **Test Case 2: CP support of network slicing**
 - Similar Set up as in Test case 1 (Multi-Vendor) with 3GPP-compliant split architecture
 - Support of different slices carrying different services:
 - 2 slices: e.g. eMBB + URLLC or eMBB + IoT
 - CP-related functionality:
 - Customization of RRC/QoS configuration per slice (e.g. mobility, power saving features, UP functions placement, numerology)

- Resource isolation
 - Optional support of Northbound APIs with inter-domain orchestrators to support e2e orchestration and verticals
- **Test Case 3: Centralized Resource allocation**
 - Test-Bed configuration:
 - Deployment set-up 1: 3GPP-compliant split architecture
 - Deployment set-up 2: External controller + 3GPP-compliant split architecture (via Southbound interface).
 - Multiple DUs and UEs to be used.
 - Inter-RRM functionality interference management
 - Sub bands usage
 - Transmission time pattern
 - Max transmission power control
 - Dynamic Scheduler on TTI basis (with External controller only)
 - Scheduler parametrization and policies.
 - Resource blocks allocation
 - Beam forming handling
 - **Sensitivity to interface transport layer performance**

The following test procedure is defined for the CP-UP separation test cases:

7. Assess performance of baseline (test case 1,2,3)
 - a. Monolithic or proprietary gNB implementation without open interfaces
 - b. Measure UE connection KPIs
8. Assess performance of CP-UP split architecture (test case 1,2,3):
 - a. Introduce usage of open interfaces
 - b. Measure UE connection KPIs
 - c. Run sensitivity on transport performance (e.g. latency).
9. Compare results with baseline and assess success criteria

3.11.2.3 Success criteria

The benchmark should be the success separating the CP functionalities and the ability to program them separately. The test should ensure that the increased programmability does not affect UE radio performance.

4 Service or technology specific requirements

This section includes testing requirements specific to certain services and applications.

4.1 Location/Positioning service

Mobile Positioning in general is the process of determining the geographical location and/or velocity of a device by measuring radio signals, and possibly some other measurements.

Location-based information can be used to locate emergency calls. There are regulatory requirements that make it mandatory for operators to be able to position these types of calls. Apart from locating people calling emergency numbers, in 5G networks positioning will play a tremendous role, enabling a vast amount of different location-based services and applications such as intelligent traffic system, unmanned aerial vehicles, robotics, tracking etc.

Especially in urban environments, 5G networks are expected to consist of densely distributed access nodes. Devices in such a dense network will be within coverage of multiple access nodes, hence enabling highly accurate positioning. High bandwidths and advanced antenna technologies are expected to provide accurate localization as well.

According to [5], 5G NR should enable, and improve if suitable, state-of-art positioning techniques, such as RAN-embedded (Cell-ID, E-Cell ID, OTDOA, UTDOA, etc.) and RAN-external (GNSS, Bluetooth, WLAN, Terrestrial Beacon Systems (TBS), sensors, etc.). Additionally, potential D2D based positioning techniques should be considered.

4.1.1 EPS Scenario (Option 3)

LTE eNB acts as a master node, C-plane connection between CN and RAN through LTE eNB (figure 4.1-1).

In this scenario, the calculation of the geographical position of a UE is according to existing LTE technology procedures.

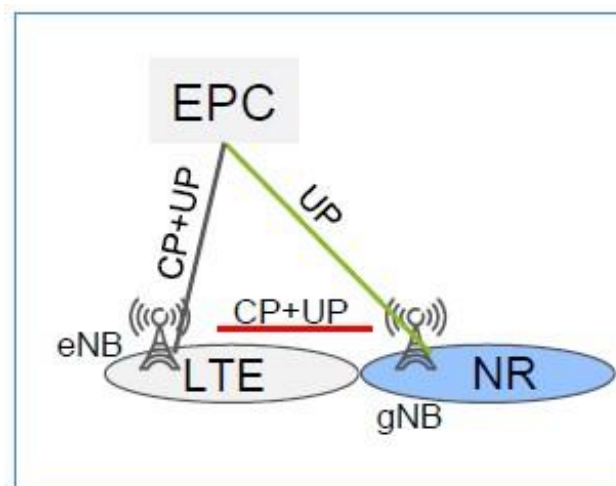

Figure 4.1.1-1 :- Network configuration

4.1.2 5GS Scenario (NG-RAN)

The NG-RAN architecture is illustrated in figure 4.1.2-1 below.

ngmn e. V.

Großer Hasenpfad 30 • 60598 Frankfurt • Germany

Phone +49 69/9 07 49 98-04 • Fax +49 69/9 07 49 98-41

According to [29], an NG-RAN node is either:

- a gNB, providing NR user plane and control plane protocol terminations towards the UE; or
- an ng-eNB, providing E-UTRA user plane and control plane protocol terminations towards the UE.

The gNBs and ng-eNBs are also connected by means of the NG interfaces to the 5GC.

UE positioning architecture applicable to NG-RAN is shown in figure 4.1.2-2.

As seen in the supported versions of UE positioning methods table 4.1.2.3 below in the current version of the specification [28] only Cell-ID method is supported for NR. This document only contains tests related to the Cell-ID method.

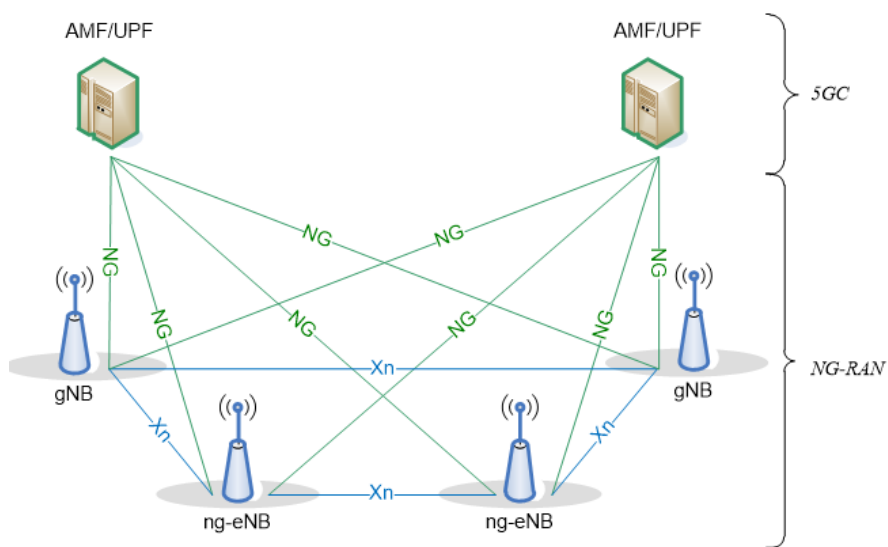

Figure 4.1.2-1: Overall Architecture

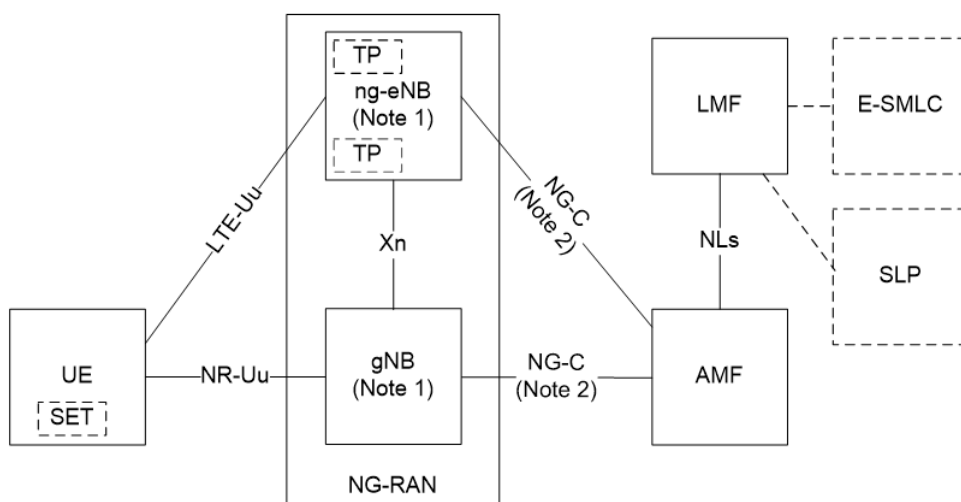

Figure 4.1.2-2: UE Positioning Architecture applicable to NG-RAN

NOTE 1: The gNB and ng-eNB may not always both be present.

NOTE 2: When both the gNB and ng-eNB are present, the NG-C interface is only present for one of them (FFS).

Method	UE-based	UE-assisted, LMF-based	NG-RAN node assisted	SUPL ^{NOTE 6}
A-GNSS	Yes	Yes	No	Yes (UE-based and UE-assisted)
OTDOA ^{Note1, Note 2}	No	Yes	No	Yes (UE-assisted)
E-CID ^{Note 3, Note 4}	No	Yes	Yes	Yes for E-UTRA (UE-assisted)
Barometric	Yes	Yes	No	No
WLAN	Yes	Yes	No	Yes
Bluetooth	No	Yes	No	No
TBS ^{Note 5}	Yes	Yes	No	Yes (MBS)

NOTE 1: This includes TBS positioning based on PRS signals.
 NOTE 2: In this version of the specification only OTDOA based on LTE signals is supported.
 NOTE 3: In this version of the specification only E-CID based on LTE signals is supported.
 NOTE 4: This includes Cell-ID for NR method.
 NOTE 5: In this version of the specification only for TBS positioning based on MBS signals.
 NOTE 6: SUPL 2.0 ([15], [16]) is not defined to support NR.

Table 4.1.2-3: Supported versions of UE positioning methods

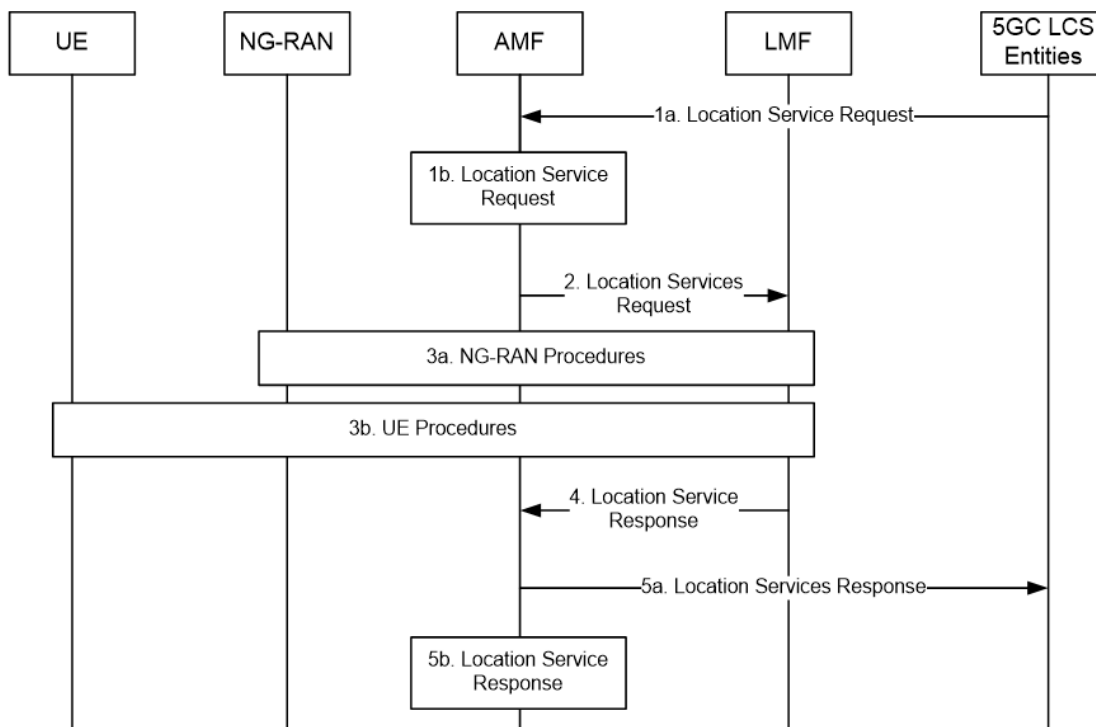

Figure 4.1.2-4: The overall sequence of events applicable to the UE, NG-RAN and LMF for any location service

4.1.2.1 Cell-ID Positioning Technique

4.1.2.1.1 Definition

- Cell ID-based positioning locates a UE based only on the serving cell ID. The UE position is provided with **ngmn e. V.**

accuracy corresponding to the cell size.

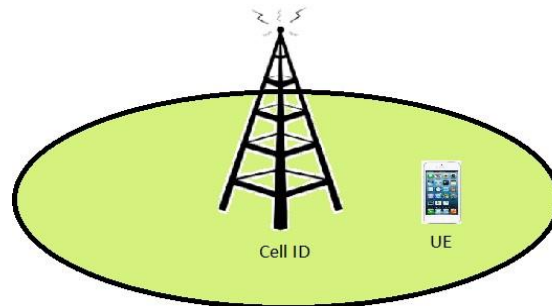

Figure 4.1.2-5 :- Cell ID Method

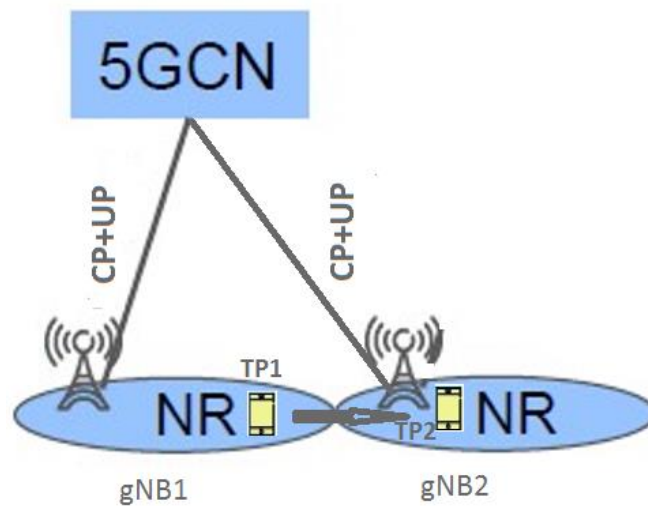

Figure 4.1.2-6 :- Cell Id Test Configuration

4.1.2.1.2 Test Environment

4.1.2.1.2.1 Test Setup

At least two 5G NR nodes and one 5G capable UE should be available. gNB 's are connected to the 5GC to the core and via the Xn interface between them.

Deployment scenario: suitable for indoor hotspot, dense urban, urban macro and rural as defined in section 2.2.

4.1.2.1.2.2 Test Configuration

See Figure 4.1.2-6 :- Cell Id Test Configuration.

4.1.2.1.2.3 Test Procedure

1. Scenario 1: As seen in the figure 4.1.2-6, UE is placed under coverage of NR1 cell at test point 1. At least 20 position queries should be initiated towards UE at TP1 while UE is in idle mode.

ngmn e. V.

Großer Hasenpfad 30 • 60598 Frankfurt • Germany

Phone +49 69/9 07 49 98-04 • Fax +49 69/9 07 49 98-41

2. Scenario 2: UE in idle mode is moved from coverage of NR1 cell to coverage of NR2 cell. At least 20 position queries should be initiated towards UE at TP2 while UE is in idle mode.
3. Scenario 3: UE is connected mode (e.g. ftp). At least 20 position interrogations should be initiated towards UE at TP1. UE will move in connected mode to the TP2 under NR2 cell. At least 20 position interrogations should be initiated towards UE at TP2.

4.1.2.1.3 **Success Criteria**

KPIs such as Positioning Response Time (latency), Positioning Accuracy, Positioning Availability should be measured.

- Latency: The time starts when the AMF obtains the Location Service Request along either 1a or 1b shown in figure 4.1.2-4.
Time stops when the position has been delivered via either 5a or 5b.
- Accuracy: The difference between the measured and the real position.
- Availability: Indication of the ability of the system to provide service.

The test results record

	Location Type	Call Count	Positioning Availability	Accuracy (cell-id)	Latency
Scenario1 TP1	Cell ID	20			
Scenario2 TP2	Cell ID	20			
Scenario3 TP1	Cell ID	20			
Scenario3 TP2	Cell ID	20			

4.1.2.1.1.1 **Table 4.1.2-7 :- Positioning Test Results**

In the Cell ID (CID) positioning method, the UE position is estimated with the knowledge of the geographical coordinates of its serving gNB. It should be verified that correct cell-id has been received. Accuracy corresponds to the cell size. Because the coverage of NR cell in general is smaller than LTE cell, better accuracy should be expected.

Latency shouldn't have significant difference compared to LTE.

Note: More accurate NR based positioning methods and standards are targeted for Release 16.

4.2 Fixed wireless access

One use case for 5G is to provide broadband access for fixed devices in residential and enterprise environments.

NOTE: It is of paramount importance to note that the scenarios defined in this section have to be considered only for a range of frequencies and available bandwidths.

In particular, the scenario of FWA is supported, in a convenient way, in a range between 6 to 30 GHz with an associated bandwidth of several hundreds of GHz.

Nevertheless, the test cases, the set-up procedure and subsequently the expected outputs can be applied for an equivalent scenario in the bands below 6 GHz.

4.2.1 Definition

In some cases, the fixed wireless access service may need to provide a guaranteed throughput and latency (e.g. DL/UL speed-tiers). In addition, the network providing fixed wireless access service may also be providing services to mobile users and utilizing the same spectrum, hardware, and baseband software.

Fixed wireless access deployments may be in urban, suburban, and rural scenarios and the user equipment (UE) / customer premise equipment (CPE) may be located indoors and outdoors (e.g. rooftop mounted).

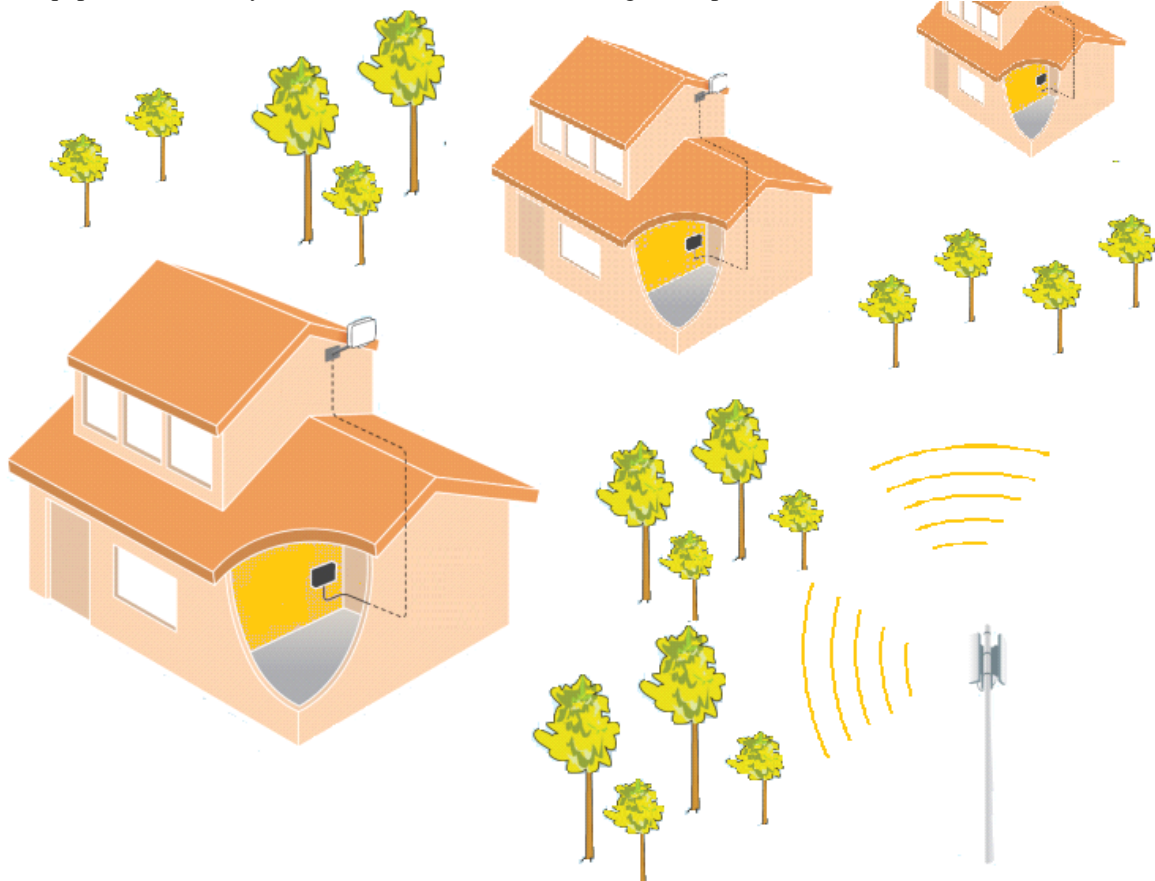

Figure 4.2-1 :- Fixed Wireless Access scenario in suburban/rural environment

Nevertheless, we consider, in this section, only the suburban and rural scenario with LoS propagation only. Actually, each use case is very specific and could require different test set up and expectation. The major difference being that we can benefit from NLOS in very dense area while in the rural one, transmitter and receiver should be in direct Line of Sight (LOS) to guarantee transmission. High frequencies being sensitive to small objects: foliage becomes an obstacle at 20 GHz.

4.2.2 Test environment

4.2.2.1 Test setup

Pre-installation

We assume an installed pre-commercial network in a specific geographical area, i.e. a number of installed base stations. A baseline coverage is measured using fixed premise test scanners identifying areas that satisfy the following criteria:

$$\text{Power}_{\text{PSS,SSS}} \geq \text{xx dBm}$$
$$[\text{Power}_{\text{BCH}} \geq \text{xx dBm}]$$

Depending on the service, additionally the coverage is determined by a service criterion. In this case the achieved throughput in DL and/or UL direction is measured assessing the end user device used in the communication link. In case of enhanced mobile broadband the following criteria is defined:

$$\text{Throughput}_{\text{DL/UL}} \geq \text{xx Mbps for at least Y\% of test time duration.}$$

Typically, the deployment scenario (number of sites, location), could be performed for two achievable throughput values being given the density of the area (density of traffic (XXGbps/km²)). Typically, we work with **30 Mbps and 100 Mbps** (European target respectively for 2020 and 2025) in the rural/suburban area. This throughput should be experienced by at least 95% of the users.

It could be considered during the test that a non-negligible percentage (for example 50%) of the tested users are watching a 4K TV show.

Configuration/deployment

Considering the rural scenario, the importance of the positioning for the LoS link CPE / trx is very important and we propose 2 different options for these tests:

- macro cells: three-sectorized antennas, height 25 m
- small cells: sectorized antennas, height 10m

3 different positioning of terminal (CPE) antennas at the customer premises

- outside, on the roof (roof-top)
- outside, on the wall close to the window (wall-mounted)
- Indoor, close to the window

Note: UE/CPE with external antenna/radio units and integrated antenna/radio units may be tested.

In addition, tests should be performed in a variety of environments:

- Indoor/outdoor commercial enterprise
- Indoor/outdoor residential environment
 - Examples include single family dwellings and multi-tenant buildings

UE/CPE with external antenna/radio units and integrated antenna/radio units may be tested.

ngmn e. V.

Großer Hasenpfad 30 • 60598 Frankfurt • Germany

Phone +49 69/9 07 49 98-04 • Fax +49 69/9 07 49 98-41

For mmWave analog beamforming and tracking should be tested in LOS/NLOS environments. This includes beam selection performance based on L1 RSRP and beam recovery/tracking during blockage events or in NLOS scenarios. Tests needs to be conducted in different environmental/weather conditions (e.g. foliage, rain) for mmWave. It would be convenient to perform the test at different period of the day to complement the results (diversity of weather condition)

Material penetration loss tests (windows, wall, roof, standard windows and coated windows)

The following test configuration options are considered:

- Conf. 1 (mmWave):
 - Carrier frequency: 28GHz or 37-40GHz band
 - Sub-carrier spacing:
 - 120kHz sub-carrier spacing for > 6GHz deployment
 - Slot length:
 - 125us (14 symbols at 120kHz)
 - System BW:
 - 100, 200, 400, or 800 MHz (50 or 100MHz CCs)
 - DL/UL ratio: 90/10, 80/20, 50/50, 20/80

4.2.2.2 Test procedure

Test configuration 1: Residential environment with single base station and outdoor CPE antenna

1. Install one pole mounted (6-10m) base station radio unit
2. Install CPE in residence with outdoor antenna mounted on rooftop and baseband unit installed indoors
3. Upon system installation determine optimal CPE antenna orientation (manual and/or analog beam-steering) based on synchronization signal RSRP.
4. Perform DL/UL throughput and latency tests using different DL/UL traffic ratios with UDP/TCP e.g. iPERF traffic generation at the CPE
5. Additionally, verify end user DL/UL throughput using client devices (e.g. WiFi router, smartphone, laptop) etc.

Test configuration 2: Residential environment with single base station indoor CPE antenna

1. Install one pole mounted (6-10m) base station radio unit
2. Install CPE in residence with integrated antenna and baseband unit installed indoors (e.g. oriented towards window)
3. If not window oriented, upon system installation determine optimal CPE antenna orientation (manual and/or analog beam-steering) based on synchronization signal RSRP
4. Perform DL/UL throughput and latency tests using different DL/UL traffic ratios with UDP/TCP e.g. iPERF traffic generation at the CPE
5. Additionally, verify end user DL/UL throughput using client devices (e.g. WiFi router, smartphone, laptop) etc.

4.2.3 Success criteria

KPIs:

- Average and peak throughput
- Meeting throughput speed tier guarantees
- End-to-end latency performance
- Beam tracking range (horizontal/azimuthal) for base station and CPE/UE antennas
- Quality of Service differentiation scenarios for Voice/video application
- Number of (active) users served per base station
- Geographic coverage area
- Robustness to environmental blockage (mmWave)

Throughput:

ngmn e. V.

Großer Hasenpfad 30 • 60598 Frankfurt • Germany

Phone +49 69/9 07 49 98-04 • Fax +49 69/9 07 49 98-41



Test with one CPE outdoor in different location including poor coverage
Test with one indoor CPE in different location including poor coverage
Test with 10 outdoors CPEs in different location including poor coverage
Test with 10 indoors CPEs in different location including poor coverage
Test with different mix of CPEs outdoor and indoor (60/40: 40/60)

All the tests need to be addressed both in uplink and downlink

QoS test with guaranteed services (Voices or Video services) in loaded and averaged traffic conditions.

Mobility of indoor devices should be considered.

4.3 Voice Services

There are different solutions for voice services over 5G NR. In this document, only EPS Fallback scenario is considered. The others will be added when standards become clearer.

4.3.1 EPS Fall-back

In 5G Standalone (SA) architecture (Option 2), Voice Services may be ensured over 5G NR, or over LTE when features for native 5G voice services are not yet implemented either in User Equipment, RAN, 5G Core or IMS.

This later case is named EPS Fall-back mechanism.

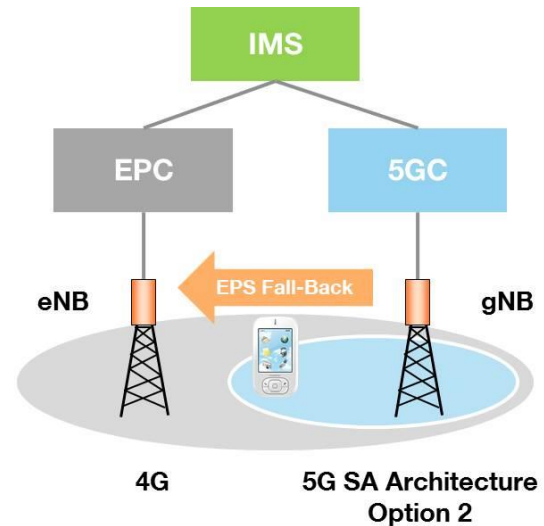

4.3.1.1 Definitions

Evaluate the delay that is needed in to establish a VoIP call using the EPS Fall-Back mechanism. According to [30], Figure 4.3.-1 describes the EPS Fall-back procedure for IMS voice.

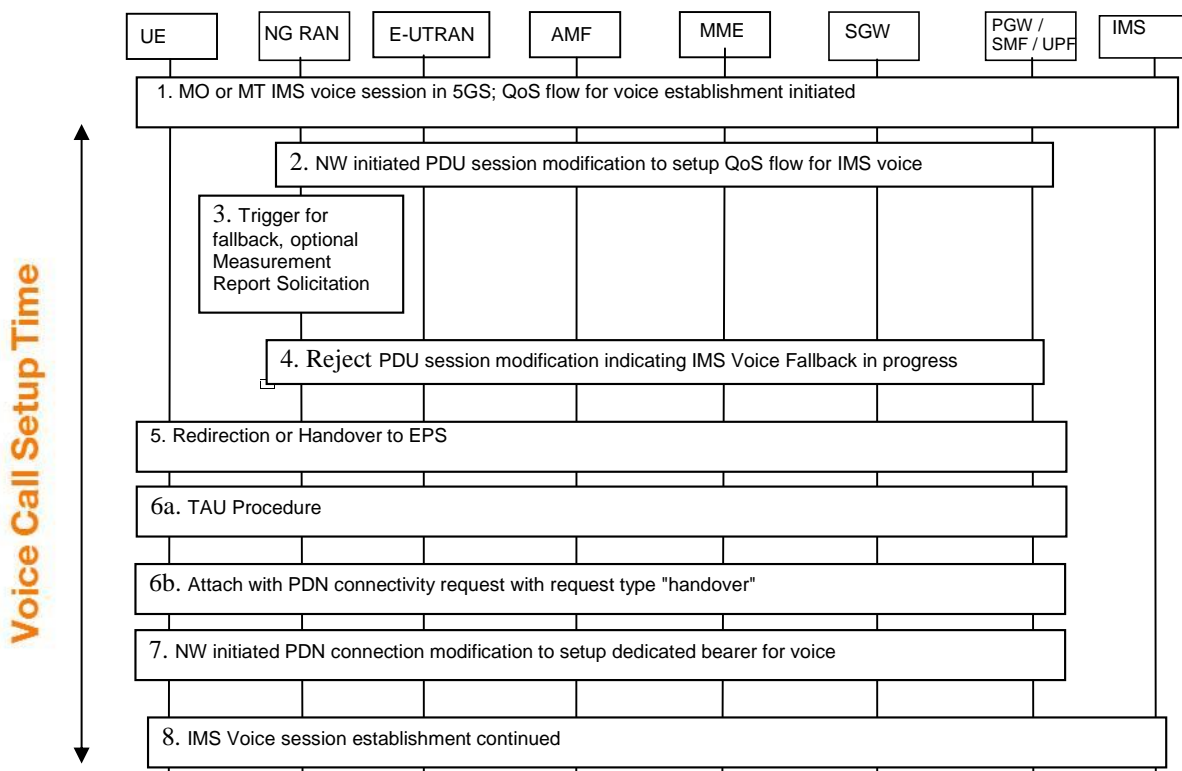

Figure 4.3-1: EPS Fallback for IMS voice



The Voice Call Setup Time may be influenced with the implementation of the N26 interface. The N26 has been introduced to be an inter-CN interface between the Mobility Management Entity (MME) in the LTE core network and 5GS Access and Mobility Management function (AMF) in order to enable interworking between EPC and the NG core.

Call Set-up Time (CST) : According to [31] - Telecommunication management; Performance Management (PM); Performance measurements; IP Multimedia Subsystem (IMS).

$$CST = (t_{Ack} - t_{INV}) - (t_{200\ OK} - t_{180\ RING})$$

Total time ($t_{Ack} - t_{INV}$) is the interval between sending INVITE message (with Session Description Protocol) and ACK message by the originating side.

Callee response time ($t_{200\ OK} - t_{180\ RING}$) is the interval between receiving 200 OK and 180 RINGING messages from the terminating side.

For a mobile to PSTN call, CST is the interval between t_{INV} and $t_{180\ RING}$.

4.3.1.2 Test environment

4.3.1.2.1 Test setup

A 5G system in a Standalone (SA) architecture is available (Option2) together with a legacy LTE system overlaying the 5G-NR coverage.

Specific means: two UEs with two PCs equipped with KPI collector software and a suitable time stamping solution (e.g. : Iperf / NTP clients).

Test conditions:

- UE in stationary condition and/or mobility conditions.
- Call Set-up Times could be measured in both bad and good radio conditions.

So please report on these conditions when delivering your tests results.

4.3.1.2.2 Test configuration

Tests are performed in an eMBB configuration either in Dense Urban or Urban Macro scenario (refer to section 2.2).

4.3.1.2.3 Logging at gNB side and UE side

On the UE side, the following metrics should be available for performance assessment:

- E2E (End to End) Latency
- Call Set-up Success Rate

4.3.1.2.4 Test Procedure

Two procedures for mobile to mobile and mobile to PSTN call scenarios shall be performed.

Mobile to Mobile Call

1. UE camps on NG-RAN and is registered in the 5GS.
2. Initiate a Mobile IMS voice session
3. Terminating UE is picked up and originating UE has sent the SIP ACK message
4. Get Latency measurement as described in the Definitions Section, through the Indicators collector software.
5. Repeat the procedure 1-3 20 times and report minimum, maximum and average Set-up times.

50 times or more is recommended when assessing the Call Set-up Success Rate.

Optionally: the number of Call Set-up and their duration may be undertaken as follow: initiate a call, call duration 5sec, end the call, after 10 sec initiate another call, (RRC release timer <10sec), ensure every time calls are initiated at idle state, total testing time no less than 1 hour, calculate the success rate and latency statistically.

Mobile to PSTN Call

ngmn e. V.

Großer Hasenpfad 30 • 60598 Frankfurt • Germany

Phone +49 69/9 07 49 98-04 • Fax +49 69/9 07 49 98-41

1. UE camps on NG-RAN and is registered in the 5GS.
2. Initiate a Mobile IMS voice session
3. Terminating PSTN terminal is picked up and originating UE has sent the SIP ACK message
4. Get Latency measurement as described in the Definitions Section, through the Indicators collector software.
5. Repeat the procedure 1-4 20 times and report minimum, maximum and average Set-up times.

50 times or more is recommended when assessing the Call Set-up Success Rate.

Optionally: the number of Call Set-up and their duration may be undertaken as follow: initiate a call, call duration 5sec, end the call, after 10 sec initiate another call, (RRC release timer <10sec), ensure every time calls are initiated at idle state, total testing time no less than 1 hour, calculate the success rate and latency statistically.

4.3.1.3 Success criteria

For eMBB use case, expected performances of the Voice Call Setup Times are indicated here:

- End to End Voice Call Setup Time with Redirection (no N26 interface) $\leq 4.5s$ (i.e.: $\sim 3s$ (VoLTE) + 1.5s)
- End to End Voice Call Setup Time with Handover and N26 interface $\leq 3.7s$ (i.e.: $\sim 3s$ (VoLTE) + 0.7s)

4.3.1.4 Reporting and analysing results

For the eMBB scenarios and for considered:

- Frequency bands (<6GHz, >6GHz),
- Duplexing modes (FDD, TDD) and TDD ratios

shall be reported.

Depending on whether or not the N26 interface is implemented, Voice Call Setup Times could drastically differ. Thus it is recommended to report times on the appropriate row of the following template.

Indicator	RF conditions (Good/Bad)	Stationary or Mobility	Scenario (to Mobile or to PSTN)	Call Setup Time	End to End Voice Call Setup Success Rate
End to End Voice Call Setup Time with no N26 interface (Blind Redirection without measurement)				ms (min, max, average)	%
End to End Voice Call Setup Time with no N26 interface (Measurement based Redirection)				ms	%
End to End Voice Call Setup Time with Handover and N26 interface				ms	%

Table 4.3-1: Voice Services Results Summary

4.3.2 Voice Over NR

4.3.2.1 Definitions

In 5G Stand Alone (SA) architecture the voice services may be directly handled by the gNB and 5GC without EPS fall back or RAT fallback. For this, the 5GC as well as the gNB and UE must support IMS voice services over 5G.

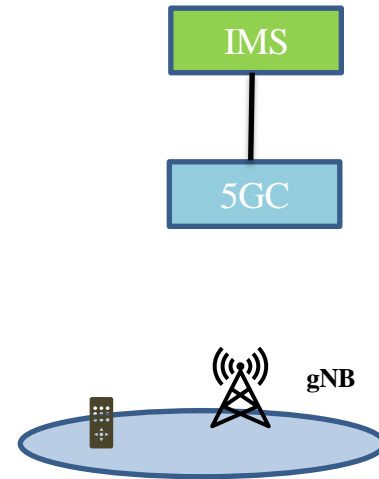

5G SA option 2 with IMS support

In particular,

- The 5GC must support IMS QoS handling requirements and IMS signaling as indicated in Annex Y.2 of the 3GPP TS 23.228.
- The gNB must support establishment a 5QI QoS flow for IMS signaling as noted in Section 5.7 of the 3GPP TS 23.501.
- The gNB must support establishment of a 5QI QoS flow for IMS Media as indicated in Section 5.7 of 3GPP TS 23.501.
- The UE must support IMS signaling and Media bearer QoS flows.

With the above capabilities the NW initiated PDU session modification request (Step 2 in Figure 4.3-1) will be accepted by the gNB and IMS voice session establishment (Step 8 Figure 4.3-1) will continue without the need for a fallback or Handover.

4.3.2.1.1 UE Attach and IMS Registration

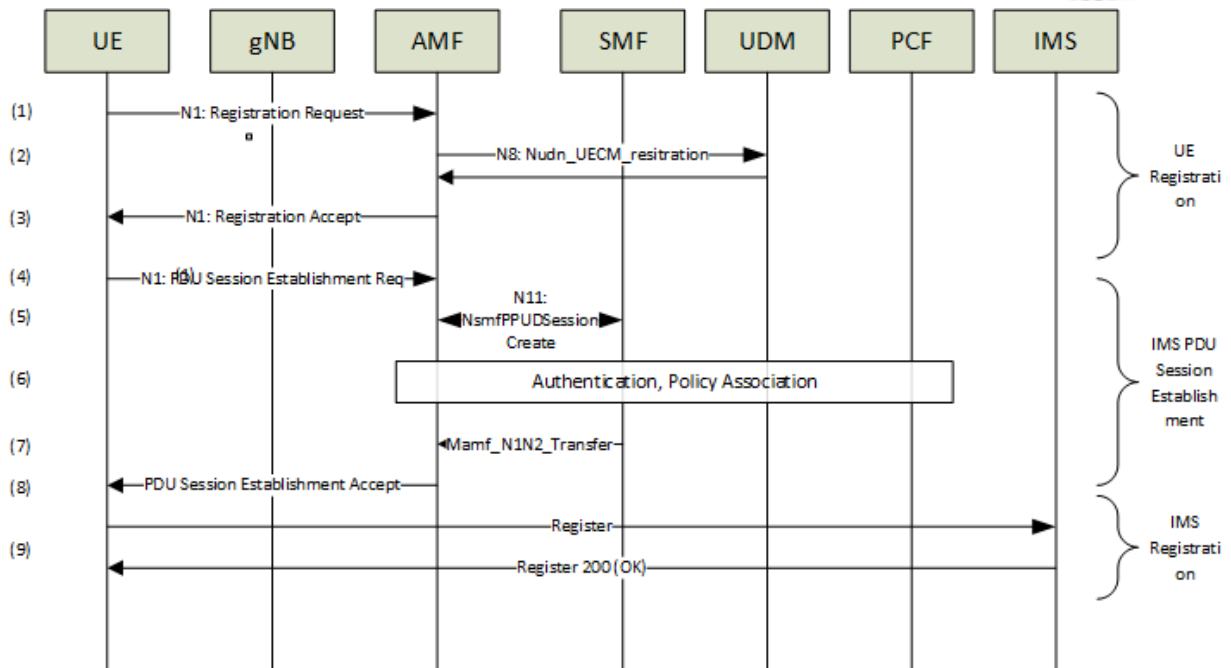

Figure 4.3-2: UE Attach and IMS Registration

1. Upon the UE power up and after establishing RRC connection with the gNB the UE attempts to attach to the 5G network by issuing a NAS message Registration Request. The UE indicates itself as being “voice centric” in the Usage Setting IE. For details refer to Section 4.2.2 of the 3GPP TS 23.502 [30].
2. The UE registration request is conveyed to UDM while the “Homogeneous Support of IMS Voice over PS Sessions” is indicated.
3. AMF stores the UE context and informs the UE of its registration accept
4. The UE sends a request for a PDU session establishment to be able to register with the IMS
5. (and 6): Following authentication and policy association with the PCF a PDU session is established for the UE. For details refer to Section 4.3.2 of the 3GPP TS 23.502 [30].
7. (and 8). The acceptance of the PDU session is conveyed to the UE along with the address list of P-CSCF that the UE can access.
9. The UE reaches the IMS P-CSCF and sends SIP register message to register for IMS services

4.3.2.1.2 MO/MT Voice Call

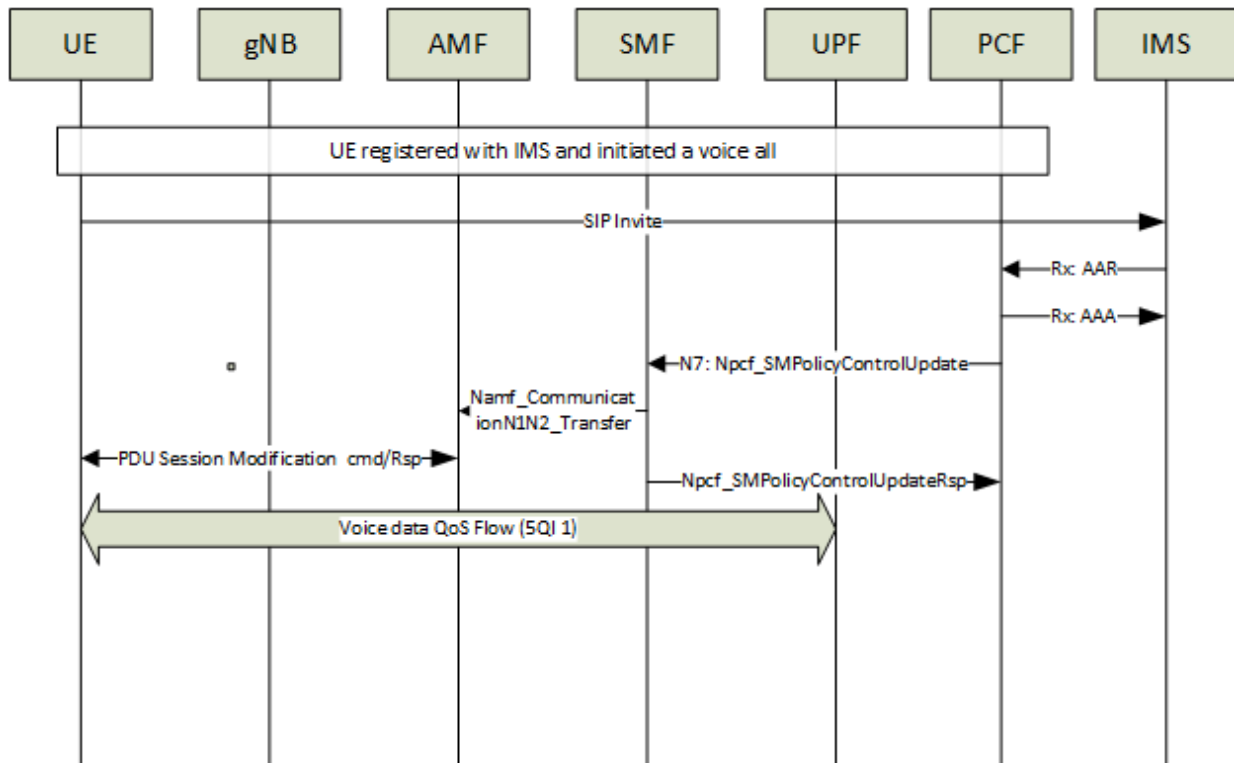

Figure 4.3-3: VoNR call.

1. A registered UE attempts a voice call or receives a page for a voice call. As part of voice service establishment of a voice centric UE a QoS bearer 5QI 5 is also established for SIP signalling.
2. The UE sends a SIP invite to the IMS
3. The IMS exchanges the notification of a new service with the PCF via AA Request (AAR) command and AA Answer (AAA).
4. The PCF informs the SMF to updates the policy information about its PDU sessions by issuing a Npcf_SMPolicyControlUpdate Request message.
5. (and 6)The SMF conveys the updates to the PDU sessions by having the AMF sending a NAS PDU Session Modification command to the UE.
7. QoS flow bearer 5QI 1 is established between the UE and UPF to exchange the Voice RTP data.

4.3.2.2 Test environment

4.3.2.2.1 Test setup

A 5G system in a Standalone (SA) architecture is available (Option2).

A 4G LTE system. The 4G system is needed for verifying 4G Originated and 4G Terminated calls.

Specific means: two UEs with two PCs equipped with KPI collector software and a suitable time stamping solution (e.g. : Iperf / NTP clients). MOS measuring tool

Test conditions:

- UE in stationary condition and/or mobility conditions.
- Call Set-up Times could be measured in both bad and good radio conditions.

So please report on these conditions when delivering your tests results.

ngmn e. V.

Großer Hasenpfad 30 • 60598 Frankfurt • Germany

Phone +49 69/9 07 49 98-04 • Fax +49 69/9 07 49 98-41

4.3.2.2.2 **Test configuration**

Tests are performed in an eMBB configuration either in Dense Urban or Urban Macro scenario (refer to section 2.2).

4.3.2.2.3 **Logging at gNB side and UE side**

On the UE side, the following metrics should be available for performance assessment:

- E2E (End to End) Latency
- Call Set-up Success Rate
- MOS scores should be measured for VoNR calls and compared with scores of VOLTE calls in similar conditions.

4.3.2.2.4 **Test Procedures**

4.3.2.2.4.1 **IMS Registration in 5G (Functional Test)**

- Power up a VoNR capable UE and let it to Register with the 5GC and then perform IMS registration
 - Refer to the call flow of Figure 4.3-2
1. On the NAS interface:
 - a. verify that UE sends Registration Request with UE Usage set as Voice Centric
 - b. Verify the AMF responds with Registration Accept
 - c. Verify the UE sends PDU Session Establishment Request to establish a IMS session (IMSubSysFg = 1)
 - d. Verify the UE receives the P-CSCF address list via the PDU Session Establishment Accept message
 2. On the N8 (AMF-UDM) interface
 - a. Verify Nudm_UECM_Registration Request/Response messages
 - b. Verify “homogeneous support for IMS Voice over PS Session” is indicated
 3. On the N11 (AMF-SMF) interface
 - a. Verify Namf_Communication_N1N2Message is initiated to convey PDU Session establishment to the UE.
 4. Verify the UE issues a SIP Register message to the P_CSCF address of the IMS.
 5. Verify the UE receives a 200 (OK) from the IMS

4.3.2.2.4.2 **5G VoNR to 5G VoNR**

- Power up two VoNR capable UEs
- Establish a voice call between the two

Functional Verification

- MO Side
 - Rx interface: Verify AAR message/AAA message carries the information such as Service Information;
 - N7 (PCF-SMF) interface:
 - Verify Npcf_SMPolicyControl_UpdateNotify Request/Response
 - N11 (AMF-SMF) Interface :
 - Verify Namf_Communication_N1N2Transfer
 - SMF initiates voice dedicated QoS flow establishing corresponding PDU Session modification procedure;
 -
- MT side:
 - N7 Interface:
 - Npcf_SMPolicyControl_UpdateNotify Request/Response, PCF notifies SMF;
 - N11 Interface :
 - Verify Namf_Communication_N1N2Transfer

- SMF initiates voice dedicated QoS flow establishing corresponding PDU Session modification procedure;;

Performance Verification

- Repeat the test in at least two locations one in good RF condition and another in poor RF condition.
- In each location repeat the test at least 10 times
- Measure the call success rate as the ratio between successful calls to call attempts
- Measure the call setup time as noted in Section 4.3.1.1.
- Measure the MOS score of the call

4.3.2.2.4.3 5G VoNR to 4G VoLTE

- Power up a VoNR capable UE under the 5G system and a VoLTE capable UE under the 4G system.
- Perform MO calls from 5G UE to the 4G UE

Functional Verification

- MO Side (5G):
 - Rx interface: Verify AAR message/AAA message carries the information such as Service Information;
 - N7 (PCF-SMF) interface:
 - Verify Npcf_SMPolicyControl_UpdateNotify Request/Response
 - N11 (AMF-SMF) Interface :
 - Verify Namf_Communication_N1N2Transfer
 - SMF initiates voice dedicated QoS flow establishing corresponding PDU Session modification procedure;
- MT Side (LTE):
 - Sh Interface:
 - Verify UDR message
 - When AS-SCC of IMS domain receives the UE's MT voice call, it sends UDR message to UDM querying the UE's T-ADS message;
 - Gx Interface
 - RAR/RAA
 - PCRF notifies PGW about creating voice dedicated bearer;
 - S5/S11:
 - Create Bearer Request/Response, PGW initiates dedicated bearer creation;

Performance Verification

- Repeat the test in at least two locations one in good RF condition and another in poor RF condition.
- In each location repeat the test at least 10 times
- Measure the call success rate as the ratio between successful calls to call attempts
- Measure the call setup time as noted in Section 4.3.1.1.
- Measure the MOS score of the call

4.3.2.2.4.4 4G VoLTE to 5G VoNR

- Power up a VoNR capable UE under the 5G system and a VoLTE capable UE under the 4G system.
- Perform MO calls from the LTE UE to the 5G UE

Functional Verification

- MO side (LTE):
 - Rx: Interface
 - AAR/AAA, carries the information such as Service Information;
 - Gx Interface:
 - RAR/RAA, PCRF notifies PGW about creating voice dedicated bearer;
 - S5/S11:

- Create Bearer Request/Response, PGW initiates dedicated bearer creation;
- MT side (5G):
 - Sh Interface :
 - UDR message, When AS-SCC of IMS domain receives the UE's MT voice call, it sends UDR message to HSS querying the UE's T-ADS message;
 - N7:
 - Npcf_SMPolicyControl_UpdateNotify Request/Response
 - PCF notifies SMF about creating voice dedicated bearer;
 - N11:
 - Namf_Communication_N1N2Transfer
 - SMF initiates voice dedicated QoS flow establishing corresponding PDU Session modification procedure;

Performance Verification

- Repeat the test in at least two locations one in good RF condition and another in poor RF condition.
- In each location repeat the test at least 10 times
- Measure the call success rate as the ratio between successful calls to call attempts
- Measure the call setup time as noted in Section 4.3.1.1.
- Measure the MOS score of the call

4.3.2.2.4.5 5G VoNR to 3G

- Power up a VoNR capable UE under the 5G system and another UE under the 3G system.
- Perform MO calls from 5G UE to the 3G UE

Performance Verification

- Repeat the test in at least two locations one in good RF condition and another in poor RF condition.
- In each location repeat the test at least 10 times
- Measure the call success rate as the ratio between successful calls to call attempts
- Measure the call setup time as noted in Section 4.3.1.1.
- Measure the MOS score of the call

4.3.2.2.4.6 3G to 5G VoNR

- Power up a VoNR capable UE under the 5G system and another UE under the 3G system.
- Perform MO calls from the 3G UE to the 5G UE

Performance Verification

- Repeat the test in at least two locations one in good RF condition and another in poor RF condition.
- In each location repeat the test at least 10 times
- Measure the call success rate as the ratio between successful calls to call attempts
- Measure the call setup time as noted in Section 4.3.1.1.
- Measure the MOS score of the call

4.3.2.3 Success criteria

For eMBB use case, expected performances of the Voice Call Setup Times are indicated here:

Call Success Rate:

- Call Success Rate under good RF condition: 100%
- Call Success Rate under poor RF condition: 90%

Call setup times:

- End to End call setup time for 5G to 5G calls: <4s
- End to End call setup time between 5G and 4G calls: <4s

ngmn e. V.

Großer Hasenpfad 30 • 60598 Frankfurt • Germany

Phone +49 69/9 07 49 98-04 • Fax +49 69/9 07 49 98-41

- End to End call setup time between 5G and 3G calls: <4s
In all cases, expected to be lower than EPS Fall-back ones

MOS Scores

- The MOS score of 5G to 5G calls must be comparable to the MOS score of LTE to LTE calls under similar RF condition.

4.3.2.4 Reporting and analysing results

For the eMBB scenarios and for considered:

- Frequency bands <6GHz
- Duplexing modes (FDD, TDD) and TDD ratios

shall be reported.

4.3.2.4.1 Call setup time, call success rate

Call setup times and Call success rates to be reported in a summary table as below.

Indicator	RF conditions (Good/Bad)	Stationary or Mobility	Scenario (5G MO or 5G MT)	Call Setup Time	End to End Voice Call Setup Success Rate
End to End Voice Call Setup time 5G – 5G				ms (min, max, average)	%
End to End Voice Call Setup Time 5G – 4G				ms	%
End to End Voice Call Setup Time 5G – 3G				ms	%

Table 4.3-2: VoNR Call setup time and success rate

4.3.2.4.2 MOS scores

To eliminate dependencies to equipment inaccuracies, MOS scores of 5G to 5G calls will be compared to 4G to 4G calls in similar RF conditions.

Indicator	RF conditions (Good/Bad)	Stationary or Mobility	MOS Score
End to End 4G – 4G MOS score			
End to End 5G – 5G MOS score			

5 Abbreviations

3GPP	Third Generation Partnership Project
ACR	Absolute category rating
AoA	Angle of arrival
API	Application programming interface
AR	Augmented reality
AS	Access stratum
BLER	Block error rate
BS	Base station
CDF	Cumulative distribution function
CN	Core network
CP	Carrier prefix
CPE	Customer premises equipment
CQI	Channel quality indicator
CSI-RS	Channel state information reference signal
DC	Dual connectivity
DMRS	Demodulation reference signal
eMBB	enhanced mobile broadband
EPC	Evolved packet core
E-SMLC	Enhanced serving mobile location centre
E-UTRAN	Evolved UMTS Terrestrial Radio Access
eV2X	enhanced vehicle to everything
FDD	Frequency division duplex
FER	Frame erasure rate
FPS	Frame per second
FTP	File transfer protocol
gNB	5G NodeB
GPS	Global positioning system
GTP	GPRS tunnelling protocol
GUI	Graphical user interface
HARQ	Hybrid automatic repeat request
IoT	Interference over thermal
IP	Internet protocol
KPI	Key performance indicator
LOS	Line of sight
LTE	Long term evolution
MCG	Master cell group
MCS	Modulation and coding scheme
MEC	Multi-access edge computing
MIMO	Multiple input multiple output
mMTC	massive machine type communication
MOS	Mean opinion score
MTU	Max transfer unit
NAS	Non-access stratum
NGC	next generation core network
NGMN	Next generation mobile networks
NLOS	Non-line of sight
NR	New radio
NSA	Non-standalone
OSI	Open Systems Interconnection
OTDOA	Observed time difference of arrival
PBCH	Physical broadcast channel
PDCCH	Physical downlink control channel

ngmn e. V.

Großer Hasenpfad 30 • 60598 Frankfurt • Germany

Phone +49 69/9 07 49 98-04 • Fax +49 69/9 07 49 98-41



PDCP	Packet Data Convergence Protocol
PDN	Packet data network
PDSCH	Physical downlink shared channel
PING	Packet internet groper
PLR	Packet loss rate
PoC	Proof of concept
PRB	Physical resource block
PSS	Primary synchronization signal
PUCCH	Physical uplink control channel
PUSCH	Physical uplink shared channel
QoE	Quality of experience
QoS	Quality of service
RAN	Radio access network
RAT	Radio access technology
RLC	Radio link control
RRC	Radio resource control
RSRP	Reference Signal Received Power
RSRQ	Reference Signal Received Quality
RTT	Round trip time
RWin	TCP receive window
SA	Standalone
SCG	Secondary cell group
SDU	Service data unit
SINR	Signal to interference and noise ratio
SNR	Signal to noise ratio
SRS	Sounding reference signal
SSS	Secondary synchronization signal
TCP	Transmission control protocol
TDD	Time division duplex
ToA	Time of arrival
TTI	Trial & Testing Initiative
UDP	User datagram protocol
UE	User equipment
uRLLC	ultra-reliable low latency communications
vBBU	Virtualized baseband unit
VR	Virtual reality

6 References

- [1] NGMN white paper: "5G white paper. Next generation mobile networks", white paper, Feb. 2015.
- [2] 3GPP TR 38.913, V14.4.0, "Study on Scenarios and Requirements for Next Generation Access Technologies (Release 14)", Oct. 2017.

ngmn e. V.

Großer Hasenpfad 30 • 60598 Frankfurt • Germany
Phone +49 69/9 07 49 98-04 • Fax +49 69/9 07 49 98-41



- [3] EU H2020 TRIANGLE project, “Deliverable D4.2 – Report on the networking capabilities provided by the testbed”, Feb. 2018.
- [4] EU H2020 TRIANGLE project, “Deliverable D2.2 – Appendix 8: Network Scenarios”, Jun. 2017.
- [5] 3GPP– TR 38.913, V14.0.0, “Study on new radio access technology Radio interface protocol aspects”, Mar. 2017.
- [6] 3GPP TS 32.407, V14.0.0, “Telecommunication management; Performance Management (PM); Performance measurements; Core Network (CN) Circuit Switched (CS) domain; UMTS and combined UMTS/GSM”, Apr. 2017.
- [7] 3GPP TS 37.340, V2.0.0, “NR; Multi-connectivity; Overall description; Stage-2”, Dec. 2017.
- [8] ITU-R M [IMT-2020.TECH PERF REQ], “Minimum requirements related to technical performance for IMT-2020 radio interface(s)” Feb. 2017.
- [9] 3GPP TR 38.804, V14.0.0, “Study on new radio access technology Radio interface protocol aspects”, Mar. 2017.
- [10] 3GPP RAN #75, RP-170741, “Way Forward on the overall 5G NR workplan”, Mar.2017.
- [11] 3GPP TS 37.340, V2.0.0, “NR; Multi-connectivity; Overall description; Stage-2”, Dec. 2017.
- [12] EU H2020 TRIANGLE project, “Deliverable D2.1 - Initial report on the testing scenarios, requirements and use cases”, Sep. 2016.
- [13] ITU T Rec. P.910, “Subjective video quality assessment methods for multimedia applications“, Apr. 2008.
- [14] Netflix, «Internet Connection Speed Recommendations», available online: <https://help.netflix.com/en/node/306>
- [15] ITU-T J.341, “Objective perceptual multimedia video quality measurement of HDTV for digital cable television in the presence of a full reference“, Mar. 2016.
- [16] ITU-T J.343.1, “Hybrid-NRe objective perceptual video quality measurement for HDTV and multimedia IP-based video services in the presence of encrypted bitstream data“, Nov. 2014.
- [17] ITU-T P.863, “Perceptual objective listening quality assessment“, Sep. 2014.
- [18] ETSI TS 102 250-2, V2.2.1, “Speech and multimedia Transmission Quality (STQ); QoS aspects for popular services in mobile networks; Part 2: Definition of Quality of Service parameters and their computation“, Apr. 2011.
- [19] ETSI TR 102 493, V1.2.1, “Speech and multimedia Transmission Quality (STQ); Guidelines for the use of Video Quality Algorithms for Mobile Applications“, Jun. 2009.
- [20] ITU-T G.1030, “Estimating end-to-end performance in IP networks for data applications“, Feb. 2014.
- [21] EU H2020 TRIANGLE project, “Deliverable D2.2 – Appendix 6: Test Specification – Mobile Devices User Experience with Reference Apps Test Specification (DRA)“, Jun. 2017.
- [22] ETSI ES 203 228, V1.2.1, “Environmental Engineering (EE); Assessment of mobile network energy efficiency“, Apr. 2017.
- [23] ETSI ES 202 706-1, V1.5.0,“ Environmental Engineering (EE); Metrics and measurement method for energy efficiency of wireless access network equipment“, Oct. 2016.
- [24] ETSI ES 202 336-12, V1.1.1, “Environmental Engineering (EE); Monitoring and control interface for infrastructure equipment (power, cooling and building environment systems used in telecommunication networks)“, Jun. 2015.
- [25] 3GPP TR 38.801, V14.0.0, “Study on new radio access technology: Radio access architecture and interfaces“, Apr. 2017.
- [26] 3GPP TS 38.401, V1.0.0, “NG-RAN; Architecture description“, Dec. 2017.
- [27] 3GPP 22.862, V14.1.0, “Feasibility study on new services and markets technology enablers for critical communications; Stage 1“, Oct. 2016.
- [28] 3GPP TS 38.305, V15.1.0, “User Equipment (UE) positioning in NG-RAN; Stage 2“, Sep. 2018.
- [29] 3GPP TS 38.300, V15.3.0, “NR and NG-RAN Overall Description; Stage 2“, Sep. 2018.
- [30] 3GPP TS 23.502, V15.3.0, “Procedures for the 5G System; Stage 2 (Release 15)“, Sep. 2018.
- [31] 3GPP TS 32.409, V15.0.0, “Telecommunication Management; Performance Management (PM); Performance Measurements; IP Multimedia Subsystem (IMS)“, Jun. 2018.



ngmn e. V.

Großer Hasenpfad 30 • 60598 Frankfurt • Germany

Phone +49 69/9 07 49 98-04 • Fax +49 69/9 07 49 98-41