



Recommendation on Base Station Antenna Standards

by NGMN Alliance

© 2017 Next Generation Mobile Networks Ltd. This document contains information that is confidential and proprietary to NGMN Ltd. The information may not be used, disclosed or reproduced without the prior written authorization of NGMN Ltd., and those so authorized may only use this information for the purpose consistent with the authorization.

The information contained in this document represents the current view held by NGMN Ltd. on the issues discussed as of the date of publication. This document is provided "as is" with no warranties whatsoever including any warranty of merchantability, non-infringement, or fitness for any particular purpose. All liability (including liability for infringement of any property rights) relating to the use of information in this document is disclaimed. No license, express or implied, to any intellectual property rights are granted herein. This document is distributed for informational purposes only and is subject to change without notice. Readers should not design products based on this document.

Commercial Address:

ngmn Ltd.,

Großer Hasenpfad 30 • 60598 Frankfurt • Germany

Phone +49 69/9 07 49 98-04 • Fax +49 69/9 07 49 98-41

Registered Office:

ngmn Ltd.,

Reading Bridge House • George Street • Reading •
Berkshire RG1 8LS • UK

Company registered in England and Wales n. 5932387,
VAT Number: GB 918713901

Version:	10.0
Date:	17-February-2017
Document Type:	Final Deliverable (Approved)
Confidentiality Class:	P - Public

Project:	N-P-BASTA
Editor / Submitter:	Andrea D'Aquino (Kathrein)
Contributors:	<p>In addition to the contributors for the previous published version the following companies have contributed to this version:</p> <p>Amphenol Commscope Deutsche Telekom Huawei Kathrein RFS Rosenberger Telecom Italia</p>
Approved by / Date:	NGMN Board, 17th February 2017

Abstract

This whitepaper addresses the performance criteria of base station antennas, by making recommendations on standards for electrical and mechanical parameters, by providing guidance on measurement and calculation practices in performance validation and production, and by recommending methods for electronic data exchange. It also addresses recommendations on applying existing environmental and reliability standards to BSAs.

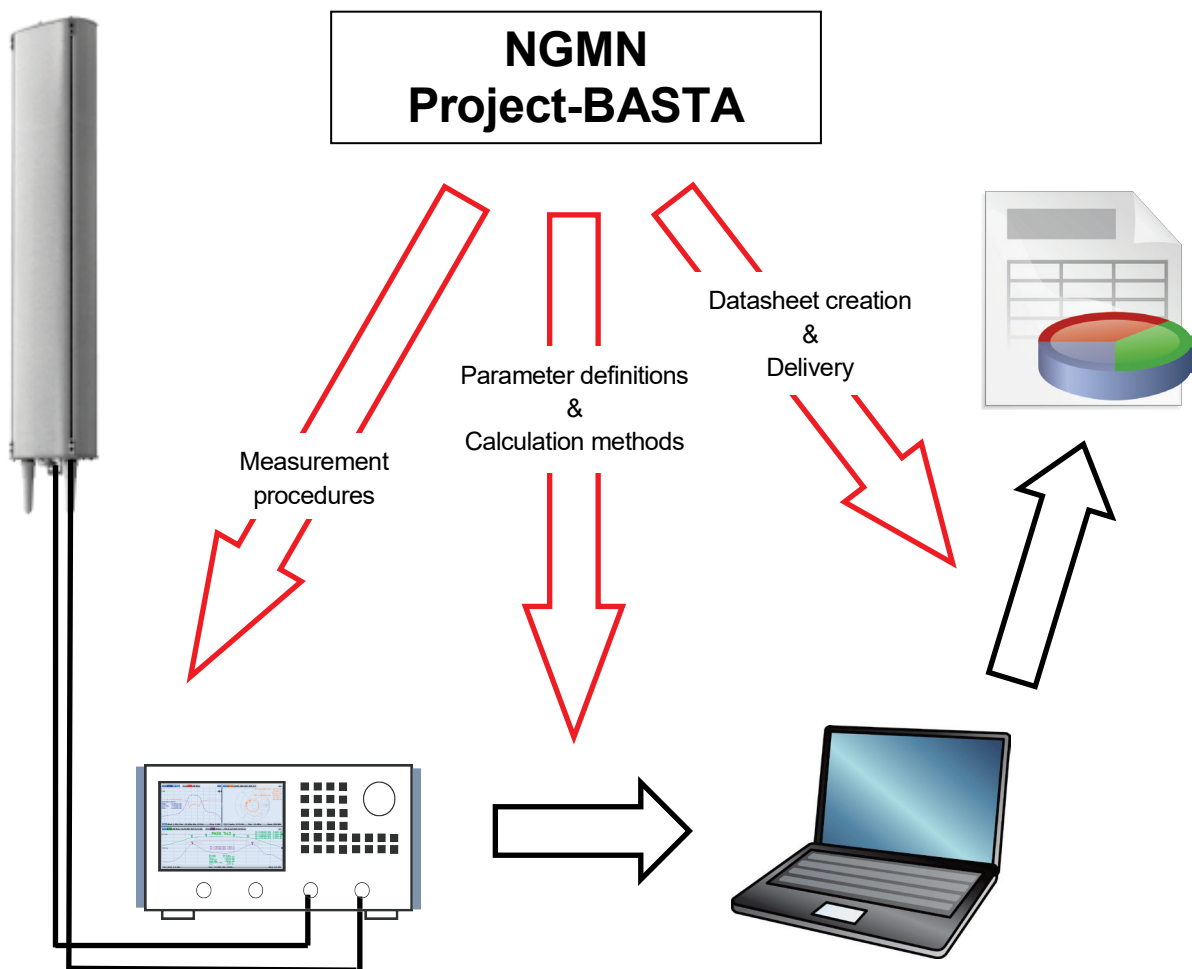

Changes from version 9.6

- Figures updated and improved, new figures added.
- History table replaced with changelog.
- Terms definition corrected.
- Whitepaper now supports omnidirectional and multi-beam antennas.
- XML tag examples in each parameter's paragraph updated.
- Parameter definitions and their specification definitions corrected.
- Notes added in the whole document to better specify definitions, scopes, etc.
- Typos and grammar corrected.
- Now the whitepaper does not contain any "must".
- Some electrical parameters added, others removed.
- Some mechanical parameters removed, others included in the electrical ones.
- Format of the whole whitepaper corrected.
- Added thorough explanation on the calculation of all the parameters concerning sidelobes.
- Added specifications on mechanical and environmental parameters.
- Windload parameter deleted. Complete review will follow in next version.
- Frequency points/samples recommendation completely changed.
- RET specifications added.
- XML chapter completely revised.
- Appendices completely revised.
- Overall wording generally improved.

Table of Contents

Recommendation on Base Station Antenna Standards	1
Changes from version 9.6.....	3
1 Introduction and Purpose of Document	10
2 Antenna Terms Definition	10
2.1 Array and Cluster	10
2.2 Radiation Intensity.....	11
2.3 Radiation Sphere	11
2.4 Far-Field Radiation Pattern	11
2.5 Far-Field Radiation Pattern Cut	11
2.6 Total Power Radiation Pattern Cut	12
2.7 Beams and Antenna Classes.....	12
2.8 Half-Power Beamwidth.....	14
2.9 Electrical Downtilt Angle	14
3 Parameter and Specifications.....	15
3.1 Format.....	15
3.2 Required RF Parameters	16
3.2.1 Frequency Range and Frequency Sub-Range	16
3.2.2 Polarization	17
3.2.3 Gain	18
3.2.4 Gain Ripple	19
3.2.5 Azimuth Beamwidth.....	19
3.2.6 Elevation Beamwidth.....	21
3.2.7 Electrical Downtilt Range	21
3.2.8 Elevation Downtilt Deviation	22
3.2.9 Impedance	23
3.2.10 Voltage Standing Wave Ratio	23
3.2.11 Return Loss	24
3.2.12 Cross-Polar Isolation	25
3.2.13 Passive Intermodulation	27
3.2.14 Front-to-Back Ratio, Total Power, $\pm 30^\circ$	28
3.2.15 First Upper Sidelobe Suppression	29
3.2.16 Upper Sidelobe Suppression, Peak to 20°	31
3.2.17 Cross-Polar Discrimination over Sector	32
3.2.18 Maximum Effective Power per Port	33
3.2.19 Maximum Effective Power Whole Antenna.....	34
3.2.20 Interband Isolation	34
3.3 Optional RF Parameters.....	36
3.3.1 Front-to-Back Ratio over 30° Angular Region - Total Power Azimuth & Elevation	36
3.3.2 Azimuth Beam Squint.....	37
3.3.3 Null Fill.....	39
3.3.4 Cross-Polar Discrimination at Mechanical boresight	40
3.3.5 Cross-Polar Discrimination over 3 dB Azimuth Beamwidth.....	41
3.3.6 Cross-Polar Discrimination over 10 dB Azimuth Beamwidth	43
3.3.7 Cross Polar Discrimination over 3 dB Elevation Beamwidth	44
3.3.8 Cross Polar Discrimination over 10 dB Elevation Beamwidth.....	44
3.3.9 Azimuth Beam Port-to-Port Tracking	45
3.3.10 Azimuth Beam H/V Tracking.....	46
3.3.11 Azimuth Beam Roll-Off.....	48
3.3.12 Upper Sidelobe Suppression, Horizon to 20°	49
3.3.13 Maximum Upper Sidelobe Level.....	50



3.3.14	Azimuth Interference Ratio	51
3.3.15	Azimuth Nominal Beam Directions	52
3.3.16	Azimuth Beam Pan Angles	53
3.3.17	Azimuth Beamwidth Fan	54
3.3.18	Maximum Effective Power of Cluster.....	56
4	Validation and Specification of RF Parameters	57
4.1	Industry Practice for Base Station Antennas.....	57
4.2	General Guidance	57
4.3	Absolute RF Parameters	58
4.4	Statistical RF Parameters.....	58
4.4.1	General methodology.....	59
4.4.2	Double-Sided Specifications	60
4.4.3	Double-Sided Specification Example–Azimuth HPBW Validation	61
4.4.4	Single-sided Specifications	64
4.4.5	Single-sided Specification Example – Azimuth Beam Port-to-Port Tracking Validation.....	65
4.4.6	Single-sided Specification Example – Upper Sidelobe Suppression, Peak to 20° Validation	68
4.5	Sidelobe Suppression Calculation and Validation	71
4.5.1	First Sidelobe Suppression	71
4.5.2	Null fill	72
4.5.3	Upper Sidelobe Suppression, Peak to 20° / Horizon to 20°	72
4.6	Gain Validation	73
4.6.1	Gain Validation for a Single Tilt Value	74
4.6.2	Gain Over All Tilts Validation	76
4.7	Validation of Elevation Downtilt Deviation	80
4.8	Guidance on Specifications Provided in Radio Planning Files	82
5	Mechanical Parameters and Specifications.....	82
5.1	Antenna Dimensions.....	82
5.2	Packing Size.....	83
5.3	Net Weight.....	84
5.4	Shipping Weight.....	84
5.5	Connector Type.....	85
5.6	Connector Quantity	85
5.7	Connector Position.....	86
5.8	Survival Wind Speed	87
5.9	Radome Material.....	87
5.10	Radome Color	88
5.11	Product Environmental Compliance	88
5.12	Mechanical Distance between Antenna Mounting Points	89
5.13	Mechanical Distance between Pole Mounting Points.....	90
5.14	Lightning Protection	91
6	Remote Electrical Tilt System.....	91
6.1	Actuator Size	92
6.2	Working Temperature Range.....	94
6.3	Power Consumption	94
6.4	Loss of Position on Power Failure	95
6.5	Compatible Standards	95
6.6	Compatible Proprietary Protocols	96
6.7	Configuration Management.....	96
6.8	Antenna Configuration File Availability	97
6.9	Antenna Configuration File Upgradability.....	97
6.10	Software Upgradability.....	98
6.11	Replaceability in Field	99



6.12	Visual Indicator Available on Tilt Change	99
6.13	Daisy Chain Available	100
7	Environmental Standards.....	100
7.1	Base Station Antenna Environmental Criteria.....	100
7.2	Environmental Test Approach.....	101
7.3	Environmental Test Methods	102
7.3.1	Packaged Storage.....	102
7.3.2	Cold Temperature Survival	102
7.3.3	Hot Temperature Survival	103
7.3.4	Temperature Cycling.....	103
7.3.5	Vibration – Sinusoidal.....	103
7.3.6	Humidity Exposure	103
7.3.7	Rain	103
7.3.8	Water Ingress.....	104
7.3.9	Dust and Sand Ingress.....	104
7.3.10	Survival Wind Speed	104
7.3.11	UV/Weather Exposure.....	104
7.3.12	Corrosion Resistance	105
7.3.13	Shock & Bump	106
7.3.14	Free Fall (Packaged Product).....	106
7.3.15	Broadband Random Vibration	107
7.3.16	Steady State Humidity	107
8	Reliability Standards.....	107
9	Additional Topics	107
9.1	Recommended Sub-bands and Associated Frequency List.....	107
9.1.1	Frequency Ranges Choice Method	109
9.1.2	Frequency Samples Choice Method.....	116
9.1.3	Compatibility with old whitepaper versions and use of non-BASTA frequencies.....	121
9.2	Guidance on Pattern and Gain Measurements	121
9.2.1	Mechanical Alignment of Test System.....	121
9.2.2	Phase Center Check.....	121
9.2.3	Antenna Pattern Testing	122
9.2.4	Pattern Accuracy Estimation.....	122
9.3	Gain Measurement	122
9.3.1	Gain by Substitution Method.....	122
9.3.2	Gain by Directivity/Loss Method	123
9.4	On the Accuracy of Gain Measurements	125
9.4.1	Antenna Mismatch between Reference Antenna and AUT	125
9.4.2	Size Difference between Reference Antenna and AUT	125
9.4.3	Temperature and Humidity Drift in Instruments.....	126
9.4.4	Polarization	126
9.4.5	Direct Gain Comparison Between Two Antennas	126
9.4.6	Reference Antennas	126
9.5	Guidance on Production Electrical Testing	126
9.6	Recommend Vendor's Reference Polarization Labelling Convention	127
10	Format for the Electronic Transfer of Specification Data	128
10.1	XML use for BSA specifications.....	129
10.1.1	Filename	132
10.1.2	Preamble	133
10.1.3	Antenna	133
10.1.4	Electrical Specifications	134
10.1.5	Cluster.....	134

10.1.6	Sub-Band.....	135
10.1.7	Mechanical and Environmental Specifications	137
10.1.8	Miscellaneous data	137
10.2	XML use for RET specifications.....	138
APPENDIX A – EXAMPLE OF ANTENNA DATASHEET		139
APPENDIX B – EXAMPLE OF RET DATASHEET		139
APPENDIX C – LOGICAL BLOCK STRUCTURE (ANTENNA+RET).....		141
APPENDIX D – EXAMPLE OF ANTENNA XML FILE		142
APPENDIX E – EXAMPLE OF RET XML FILE.....		148
APPENDIX F – GLOSSARY		149

List of Figures

Figure 1—Possible difference between array and clusters.....	11
Figure 2—Conical and great circle cuts over the radiation sphere.....	12
Figure 3—Example of a dual-beam antenna.....	13
Figure 4—Azimuth pattern of a multi-beam antenna type II.....	14
Figure 5—Electrical downtilt angle.....	15
Figure 6—Calculation of azimuth beamwidth.....	20
Figure 7—Example of VSWR measurement of an antenna port.....	24
Figure 8—Example of a return loss measurement on a single antenna port.....	25
Figure 9—Cross-polar isolation example: single cluster antenna.....	26
Figure 10—Cross-polar isolation example: dual cluster antenna.....	26
Figure 11—Example of a cross-polar isolation measurement between two antenna ports.....	27
Figure 12—Angular region for front-to-back, total power $\pm 30^\circ$ of a 0° mechanical boresight antenna.....	28
Figure 13—First upper sidelobe suppression.....	30
Figure 14—Upper sidelobe suppression, peak to 20°	31
Figure 15—Cross-polar discrimination over sector of a 0° mechanical boresight, 60° nominal horizontal HPBW antenna.....	32
Figure 16—Interband isolation examples. In this example, the interband isolation is the worst case of S41, S31, S42 and S32.....	35
Figure 17—Interband isolation vs. frequency on a single pair of ports.....	35
Figure 18—F/B angular regions, azimuth and elevation.....	36
Figure 19—Illustration of beam squint calculation for a given frequency, tilt and port.....	37
Figure 20—Identification of the lower first null.....	39
Figure 21—Cross-polar discrimination at mechanical boresight.....	40
Figure 22—Cross pol discrimination over 3 dB azimuth beamwidth.....	41
Figure 23—Cross pol discrimination over 10 dB azimuth beamwidth.....	43
Figure 24—Azimuth beam port-to-port tracking.....	45
Figure 25—Azimuth beam H/V tracking.....	47
Figure 26—Azimuth beam roll-off.....	48
Figure 27—Upper sidelobe suppression, horizon to 20°	49
Figure 28—Maximum Upper Sidelobe Level.....	50
Figure 29—Some patterns of an azimuth beam steering antenna (pan angles: -30° ; 0° ; $+30^\circ$).....	53
Figure 30—Patterns of a variable azimuth beamwidth BSA ($35^\circ/65^\circ/105^\circ$ pattern overlays).....	55
Figure 31—Double-sided specification for a normal distribution.....	60
Figure 32—Algorithm to find "mean - tolerance" and "mean + tolerance".....	61
Figure 33—Azimuth beam-peak patterns plots - 1710-1880 MHz, all ports, and all tilts.....	61
Figure 34—Azimuth HPBW for each tilt and port as a function of the frequency.....	63
Figure 35—Histogram of azimuth HPBW values.....	64
Figure 36—Single-sided specification (maximum).....	64
Figure 37—Single-sided specification (minimum).....	65

Figure 38—Algorithm to find "maximum" and "minimum".	65
Figure 39—Polarizations pattern level difference of a 90° sector antenna for one frequency and a single downtilt degree.	66
Figure 40—Azimuth beam port-to-port tracking for each tilt and port as a function of the frequency.	67
Figure 41—Histogram azimuth beam port-to-port tracking.	68
Figure 42—Worst sidelobe peak 20° above the main beam peak for one frequency, a single port and a single downtilt degree.	69
Figure 43—Histogram Upper sidelobe suppression, peak to 20°.	70
Figure 44—First upper sidelobe merged into main beam.	71
Figure 45—Gain plot for 0° tilt, both ports.	75
Figure 46—Gain histogram.	75
Figure 47—Gain plot with repeatability margin.	76
Figure 48—Gain for each tilt and port as a function of the frequency.	78
Figure 49—Gain histogram.	78
Figure 50—Gain plot with repeatability margin.	79
Figure 51—Elevation pattern plots – 1710-1880 MHz, all ports, and all tilts.	80
Figure 52—Antenna dimensions example.	83
Figure 53—Potential differences between “distance between antenna mounting points” and “distance between pole mounting points”.	90
Figure 54—Example of an external RET.	92
Figure 55—Example of the height dimension of an installed partially external RET. Its protrusion out of the antenna lies along the antenna height plane (H).	92
Figure 56—Examples of frequency samples redundancy optimization.	118
Figure 57—Spherical near-field system.	123
Figure 58—Block diagram of loss measurement.	124
Figure 59—Example of polarization conventional label.	127
Figure 60—Polarization conventional label affixed on the antenna back.	128
Figure 61—Ports identified by polarization.	128
Figure 62—Block-scheme of an antenna.	130

List of Tables

Table 1—Parameter dataset – single sub-band, all tilts, all ports.	59
Table 2—Complete dataset of azimuth HPBWs.	62
Table 3—Summary of azimuth HPBW statistics.	62
Table 4—Complete dataset azimuth beam port-to-port tracking.	66
Table 5—Summary of azimuth beam port-to-port tracking statistics.	66
Table 6—Complete dataset for gain (1710-1880 MHz, 0° tilt).	74
Table 7—Summary of gain statistics (1710 – 1880 MHz, 0° tilt).	74
Table 8—Complete dataset of gain.	76
Table 9—Summary of gain statistics, over all tilts, 1850-1990 MHz.	77
Table 10—Complete dataset elevation downtilt deviation.	81
Table 11—ETSI 300 019-1-4 stationary, non-weather protected environmental classes.	101
Table 12—Free fall test heights.	106
Table 13—E-UTRA operating bands (ETSI TS 136 521-1, v13.1.0, 2016-05).	109
Table 14—Sorted frequency table.	111
Table 15—Frequency table after sub-bands unifications.	112
Table 16—Frequency table after sub-bands divisions.	114
Table 17—Frequency table at the end of the merging/splitting/sorting processes.	115
Table 18—Frequency sampling.	116
Table 19—Samples associated to sub-bands’ portions.	117
Table 20—Final frequency table. Samples undergoing optimization are highlighted.	120

1 Introduction and Purpose of Document

The performance of a BSA is a key factor in the overall performance and quality of the cellular communication link between a handset and the radio and, by extension, of the performance of a single cell, or of an entire cellular network. The BSA's influence on coverage, capacity, and QoS is extensive, and yet there exists no comprehensive, global, standard focusing on the base station antenna. The purpose of this whitepaper is to address this gap. In particular, the following topics will be covered in various degrees of detail:

- Definitions of common BSA electrical and mechanical parameters and specifications.
- Relevance of individual BSA parameters to network performance.
- Issues surrounding various parameters.
- Guidance on antenna measurement practices in design and production.
- Recommendations on:
 - Applying statistical methods to the calculation and validation of specifications.
 - Applying existing environmental and reliability standards to BSA systems.
 - A format for the electronic transfer of BSA specifications from vendor to operator.

The scope of this paper is limited **to passive base station antennas**. Even though antennas will not be categorized in performance-classes, this paper will address antennas built for different purposes. **The operating range of the addressed antennas shall be limited within the 400 MHz - 6000 MHz spectrum.**

2 Antenna Terms Definition

This section reports the definition of commonly used antenna terms. Most definitions are based on the IEEE Standard (*IEEE Standard definitions of Terms for Antennas, IEEE Std. 145-1993 or following versions*), tailored to the class of antennas under test by means of notes.

2.1 Array and Cluster

An array is a logical group of single or dual polarized radiators inside the antenna radome supporting a common frequency band and a common beam shape and tilt. A cluster is a logical group of single or dual polarized radiators inside the antenna radome, which are connected to a single (for single-polarized radiators) port or to a pair (for dual-polarized radiators) of ports. More than one cluster can belong to a single array, but typically, array and cluster coincide. In this paper it is recommended the clusters shall follow the same naming rules as for the arrays in the latest AISG Standard for port color coding.

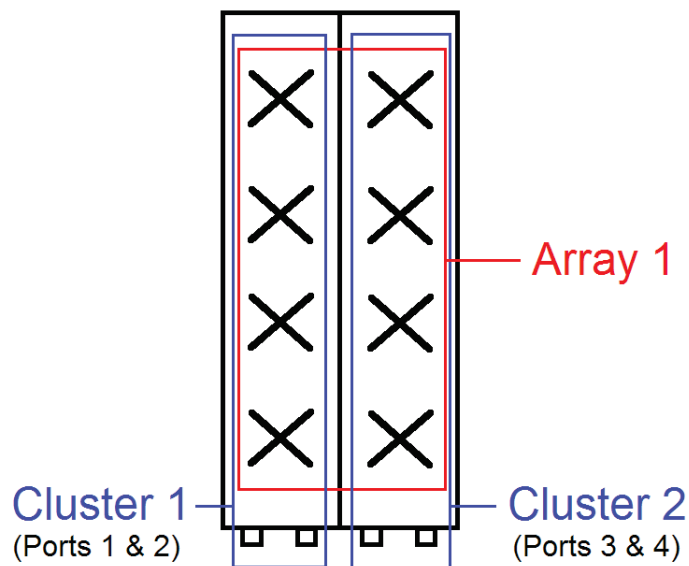

Figure 1—Possible difference between array and clusters.

Note: More information about radiator polarization can be found in Section 3.2.2.

2.2 Radiation Intensity

Radiation intensity is the power radiated from an antenna per unit solid angle in a given direction.

2.3 Radiation Sphere

Radiation sphere is a large sphere surrounding the antenna, over which quantities characterizing the radiation are determined. The sphere center is located in the antenna volume and the surface is in the antenna far-field.

2.4 Far-Field Radiation Pattern

The far-field radiation pattern (or antenna pattern) is the spatial distribution of the electric field generated by an antenna in the Fraunhofer zone.

2.5 Far-Field Radiation Pattern Cut

The far-field radiation pattern cut is any path on the radiation sphere over which a radiation pattern is obtained.

The path formed by the locus of points for which ϑ is a specified constant and ϕ is a variable is called a conical cut. The conical cut containing the main beam peak is called azimuth cut, while the cut with ϑ equal to 90° is called horizontal cut. In this document the azimuth cut will also be referred to as **azimuth pattern**.

The path formed by the locus of points for which ϕ is a specified constant and ϑ is a variable is called a great circle cut. The great circle cut containing the main beam peak is called elevation cut or vertical cut. In this document the elevation cut will also be referred to as **elevation pattern**.

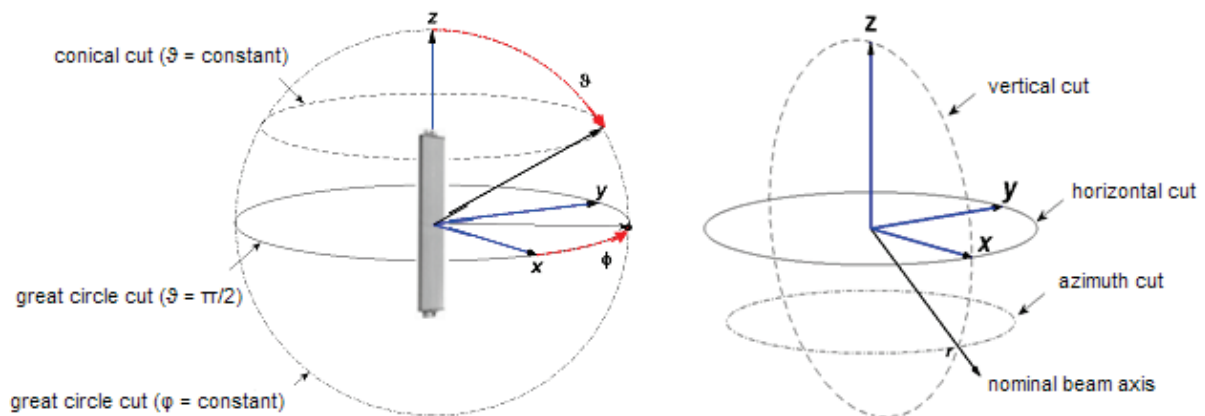

Figure 2—Conical and great circle cuts over the radiation sphere.

2.6 Total Power Radiation Pattern Cut

The total power radiation pattern cut is obtained by measuring in far-field two orthogonal polarization components of the electric field radiated by the antenna on a specific pattern cut. Let L_V and L_H the values in dB of those components. The total power radiation pattern cut is computed in dB by adding the two as follows:

$$L_{total} [dB] = 10 \cdot \log_{10} (10^{L_V/10} + 10^{L_H/10})$$

and by normalizing it with respect to the maximum.

2.7 Beams and Antenna Classes

The main beam is defined as the major lobe of the radiation pattern of an antenna. The main beam peak axis is the direction, within the main beam, along which the radiation intensity is maximum. All the other lobes are called sidelobes or grating lobes.

In this document several classes of antennas will be addressed:

- Omnidirectional antennas (also known as omni-antennas) are those able to irradiate, at all their supported frequencies, a “donut-shaped” main beam, which exhibits for the whole turn (360°) in the azimuth plane low fluctuations of radiation intensity in comparison to the main beam peak.
- Directional single-beam antennas are those able to irradiate, at all their supported frequencies, only one main beam, which has also the peculiarity to be the only beam containing all the points in the antenna’s patterns that lie between the main beam peak and its half-power boundaries.
- Directional multi-beam antennas are those able to radiate more than one main beam at the same frequency and at the same time on the azimuth plane; each of these beam is typically associated with a Pair of ports (one for each polarization). There are two kinds of multi-beam antennas:
 - Those whose main beams are each physically due to a single cluster; in this case the specifications of each beam coincide with the ones of the cluster. These antennas will be from now on indicated as multi-beam type I.
 - Those whose set of beams can be formed by properly feeding each port and combining each contribution (e.g.: planar phased-array antennas). In this case there is no physical correspondence between beam and cluster, and generally each beam is conceptually paired with a pair of ports. Since it is useful to have specifications for each beam, only as a device those

shall be indicated by associating a cluster to each pair of ports, therefore to each relevant beam. These antennas will be from now on indicated as multi-beam type II.

In this document the axis perpendicular to the antenna aperture will be called **mechanical boresight**.

Note: omnidirectional and directional single-beam antennas are basically defined by their properties, while multi-beam antennas are defined by their use.

Note: multi-beam antennas can have only a single mounting orientation, but more mechanical boresights, which may be distinct for each aperture, may not point to the mounting orientation and may also point to different directions. Those mechanical boresights should always be visually recognizable.

Note: For the purpose of this whitepaper, omni-directional antennas shall have no mechanical boresight. Parameters normally referring to the mechanical boresight will, instead, have the horizon (great circle cut $\vartheta = \pi/2$) as reference.

Note: each beam of multi-beam antennas type II has a nominal direction which can differ from that beam's peak axis, its mounting orientation and/or its mechanical boresight. Those nominal directions are defined by a specific parameter (see Section 3.3.15).

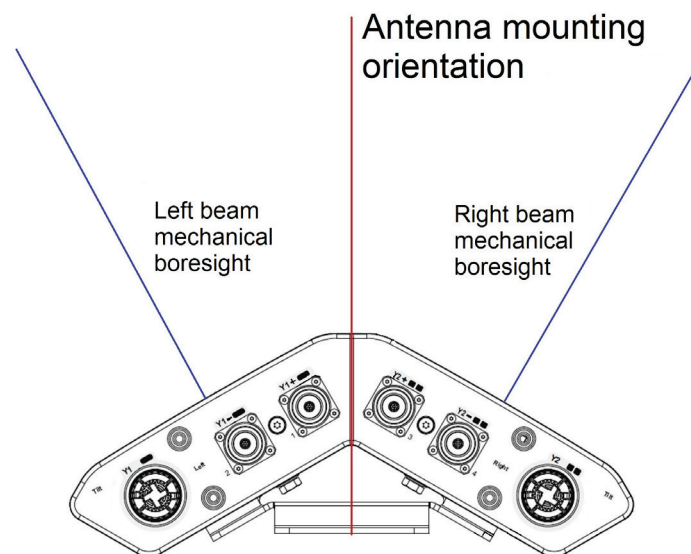

Figure 3—Example of a dual-beam antenna.
Its mounting orientation is aligned along 0° . Left and right mechanical boresights are respectively pointed to -30° and $+30^\circ$.

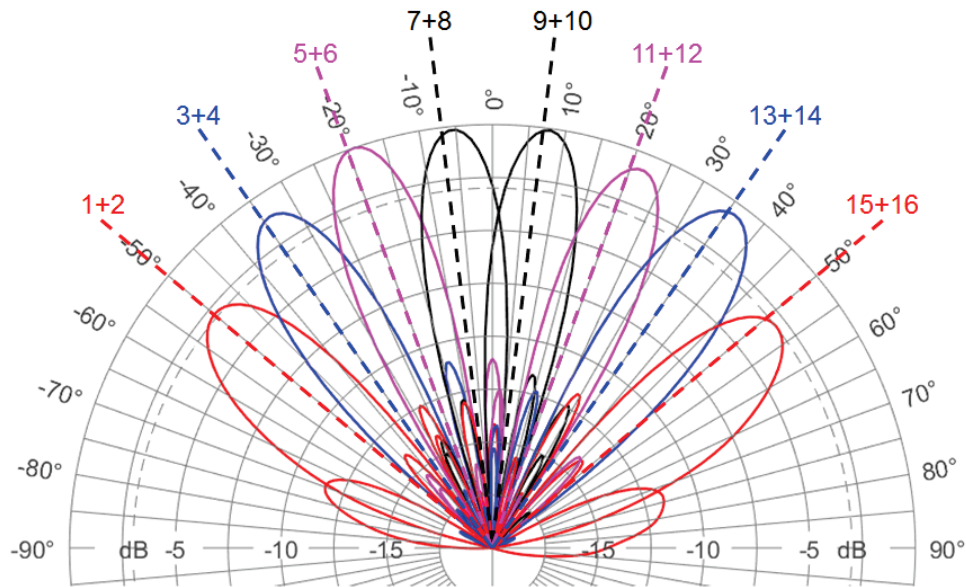

Figure 4—Azimuth pattern of a multi-beam antenna type II.
Mounting orientation and mechanical boresight are aligned along 0°. Nominal directions are noted with dotted lines. Each beam is associated to a pair of ports only as a device. All the 16 ports collaborate to produce the pattern shown.

2.8 Half-Power Beamwidth

The HPBW is, in a radiation pattern cut containing the beam peak axis, the angle between the two closest directions in which the radiation intensity is one-half the maximum value; its bisect will be here called half-power beam axis. Principal half-power beamwidths (of the antenna beam) are, for a pattern whose beam has a half-power contour that is essentially elliptical, the half-power beamwidths in the two pattern cuts that contain the major and minor axes of the ellipse.

In this paper the principal half-power beamwidths are the half-power beamwidth in the azimuth cut and elevation cut.

The nominal horizontal HPBW (HPBW of the azimuth cut), is a coarse approximation of half the area covered by the BSA and is normally used to classify different types of antennas. The angular region equal to two times the nominal horizontal HPBW, which extends symmetrically in respect to the mechanical boresight, is in this paper named as antenna sector (or sector).

Example: A 60° nominal horizontal HPBW BSA is expected to have more or less a coverage up to 60° clockwise and up to 60° counterclockwise in respect to the mechanical boresight. The angle included in those boundaries (120° in this case) is the antenna sector.

Note: For omnidirectional antennas, the H HPBW shall not be given.

2.9 Electrical Downtilt Angle

The electrical downtilt angle is, in the elevation cut, the angle between the antenna mechanical boresight and the half-power beam axis (Figure 5). An electrical downtilt is achieved by tuning the feeding-phase of the radiating elements of an antenna, and not by mechanically tilting the antenna itself.

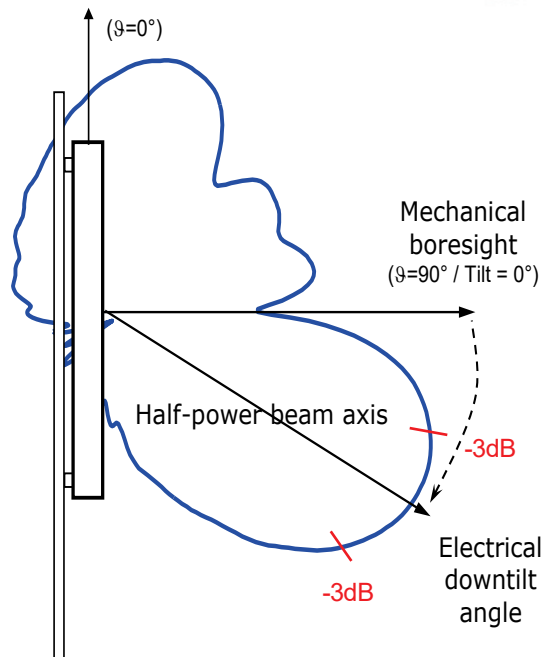

Figure 5—Electrical downtilt angle.

Since omnidirectional antennas have (as specified in Section 2.7) no boresight, their electrical downtilt angle shall be calculated in the appropriate elevation cut with the whole horizontal cut ($\vartheta = 90^\circ$) as a zero reference. In this case the half-power beam axis might lie along an angle enclosed by $\vartheta = 180^\circ$ and $\vartheta = 360^\circ$. Should this happen, in order to have consistent data, the electrical downtilt angle to consider shall be one mirrored around the $\vartheta = 0^\circ$ (or $\vartheta = \pm 180^\circ$) axis instead.

3 Parameter and Specifications

3.1 Format

In this paper the parameters will be classified as required or optional.

The following format will be used for specifications:

Parameter Name

Parameter Definition

- A description of the parameter in terms of the antenna properties using standard antenna and cellular communications terminology.

Note: If for any reason it is not possible to describe a particular case with a parameter, due to the impossibility to fully identify the case within the parameter's definition, that very parameter is said to be not applicable.

Specification Definition

- A definition for each element of the specification and associated unit of measure.

- The specification, if not absolute, will be identified as a nominal or statistical (see Sections 4.3 and 4.4).
- A description of the specification's area of validity.
- The specification's measurement unit.

Note: For the purpose of this document, the numeric values associated to each parameter shall be always positive when not otherwise specified.

Specification Example

- An example of the full specification.

XML - Tag Example

- Provides an example for the XML tag, in order to show its uniqueness.
- If a certain value is only valid in a certain range of the antenna (e.g. frequency range) this is specified in the cluster section of the XML file.
- May provide additional information for the application of the tag.
- A tag can contain the optional attribute `applicable="false"` if the parameter is not applicable.

Note: See also Chapter 10.

Note: For the purpose of this document, the precision of the values associated to each parameter shall mostly be limited to a single decimal number, even though in some cases an integer number will suffice. The "XML – Tag Example" paragraphs will always contain an example written with the correct precision to use in each case.

Relevance

- A short description of the impact of the parameter to the antenna performance and/or communication network performance. Supplementary information may be provided in the additional topics section of the whitepaper.
- If needed, an elaboration on issues surrounding the parameter and its specification will be addressed here or in the additional topics section of the whitepaper.

Note: A figure illustrating the parameter and specification will be provided where applicable.

3.2 Required RF Parameters

Mechanical boresight (already defined in Section 2.7) and nominal horizontal HPBW (already defined in Section 2.8) shall also be included in the required parameters list.

3.2.1 Frequency Range and Frequency Sub-Range

Parameter Definition

- The frequency range is the main operating bandwidth of the antenna that is defined by a continuous range between two limiting frequencies f_{START} and f_{STOP} .
- The frequency sub-range (or sub-band) is a specific operating bandwidth included in a frequency range and defined by a continuous range between two limiting frequencies f'_{START} and f'_{STOP} .

Specification Definition

- Ranges are specified in MHz.

Specification Example

- *Type: Absolute*
 - Frequency Range 1710-2170 MHz
 - Frequency Sub-Range 1710-1880 MHz

XML - Tag Example

```
<frequency_range start="1710" stop="2170"/>
<frequency_sub_range start="1710" stop="1880">
```

Relevance

- On a datasheet, all specifications valid for the stated frequency range are also valid for its included frequency sub-bands. Vice versa all specifications valid for the stated frequency sub-range are not valid outside that very range.
- Most BSAs are broadband and they cover one or more frequency sub-range.
- See Section 9.1 for an example of cellular frequency sub-bands.

3.2.2 Polarization

Parameter Definition

- The nominal polarization associated to the antenna port whose related radiators generate a wave polarized (nominally) along the same plane.

Specification Definition

- The nominal value as a type and direction for the reference polarization of the antenna.
- Horizontal and vertical linear polarizations are typically defined as H and V.
- Slant linear polarizations are typically defined as +45 and -45.
- Circular polarizations are typically defined as RHCP and LHCP.

Specification Example

<i>Type: Nominal</i>	1710-2170 MHz	
Polarization	Port 1	Port 2
	+45	-45

XML - Tag Example

```
<port name="1" polarization="+45" location="bottom" connector_type="7-16f"/>
<port name="2" polarization="+45" location="bottom" connector_type="7-16f"/>
```

The polarization is provided as a value for a single port and associated to a port's name.

Relevance

- Two orthogonal polarizations are often radiated from an antenna to provide diversity. This is typically used in uplink and MIMO applications.
- Antennas that radiate two orthogonal polarizations are typically called “dual-pol”.
- A recommended vendor reference to the polarization labeling convention is described in Section 9.5.

3.2.3 Gain

Parameter Definition

- According to IEEE-145 (1993) definition, the antenna gain is the ratio of the radiation intensity (the power radiated per unit solid angle), in a given direction, to the radiation intensity that would be obtained if the accepted power at the antenna port were radiated isotropically.

Specification Definition

- Gain is a typical (mean) value in dBi.
- It is specified for the specific lowest (minimum), middle, and highest (maximum) downtilt angles of the whole tilt range for each frequency sub-band.
- In addition, the “over all tilts” gain is specified by a mean value and a tolerance, both over the whole tilt range and for each frequency sub-band. This is a double-sided statistical parameter. Tolerance is in dB.
- Gain validation is determined by the statistical methodology described in Section 4.6 .
- This parameter is to be defined for each frequency sub-band in a broadband antenna. It will be assumed that the specification is valid for all the ports associated with each frequency sub-band of the antenna.
- The repeatability margin associated with a specified mean gain is defined in Section 4.6 .
- A discussion of guidelines for a gain measurement is presented in Section 9.2 and a discussion of the measurement accuracy that can be expected when measuring gain on a far-field range is discussed in Section 9.4 .

Specification Example

<i>Type: Statistical</i>	1710-1880 MHz	1850-1990 MHz	1920-2170 MHz
Gain at 0° Tilt	17.1	17.4	17.7
Gain at 5° Tilt	17.3	17.5	17.7
Gain at 10° Tilt	17.0	17.0	17.2
Over all tilts (0°-10°)	17.2 ± 0.2	17.4 ± 0.3	17.5 ± 0.3

XML - Tag Example

```
<gain_at_tilt min="17.4" mid="17.5" max="17.0"/>
<gain_over_all_tilts value="17.4" tolerance="0.3"/>
```

Relevance

- Primary specification used in the calculation of a link budget.

- The gain specified in radiation pattern data files is used by radio planning software to predict coverage and capacity performance of a cell.

3.2.4 Gain Ripple

Parameter Definition

- For an omnidirectional antenna, gain ripple is the ratio between the lowest level of the azimuth pattern and its peak.

Note: If the antenna is a single-beam or multi-beam, this parameter shall not be given. Vice versa, it shall be treated as required for omnidirectional antennas.

Specification Definition

- Gain ripple is a maximum value in dB.
- It is the difference between the highest and lowest azimuth pattern level, if both are considered in dB.
- Pattern levels for this parameter shall be taken with a 1° angular resolution.
- It is subject to a statistical validation for a single-sided parameter.
- This parameter is to be defined for the nominal sub-bands in a broadband antenna. It will be assumed that the specification is valid for the full electrical downtilt range, and for all the ports associated with each frequency sub-band of the antenna.

Specification Example

<i>Type: Statistical</i>	1710-1880 MHz	1850-1990 MHz	1920-2170 MHz
Gain Ripple	< 3.0	< 4.1	< 3.9

XML - Tag Example

```
<gain_ripple value="3.2"/>
```

Relevance

- This parameter gives an estimation of the “roundness” of the azimuth pattern.
- It is the most characterizing parameter for omni antennas’ radiation in the azimuth plane.
- An ideal antenna, which radiates perfectly in every direction in the azimuth plane, would have a gain ripple of 0.0 dB.

3.2.5 Azimuth Beamwidth

Parameter Definition

- The 3 dB (or half-power) azimuth beamwidth of the antenna is defined in the azimuth radiation pattern as the angular width including the main beam peak, which extends between the only two points at a beam level 3 dB lower than the maximum of radiation, which are also the nearest to the main beam peak.

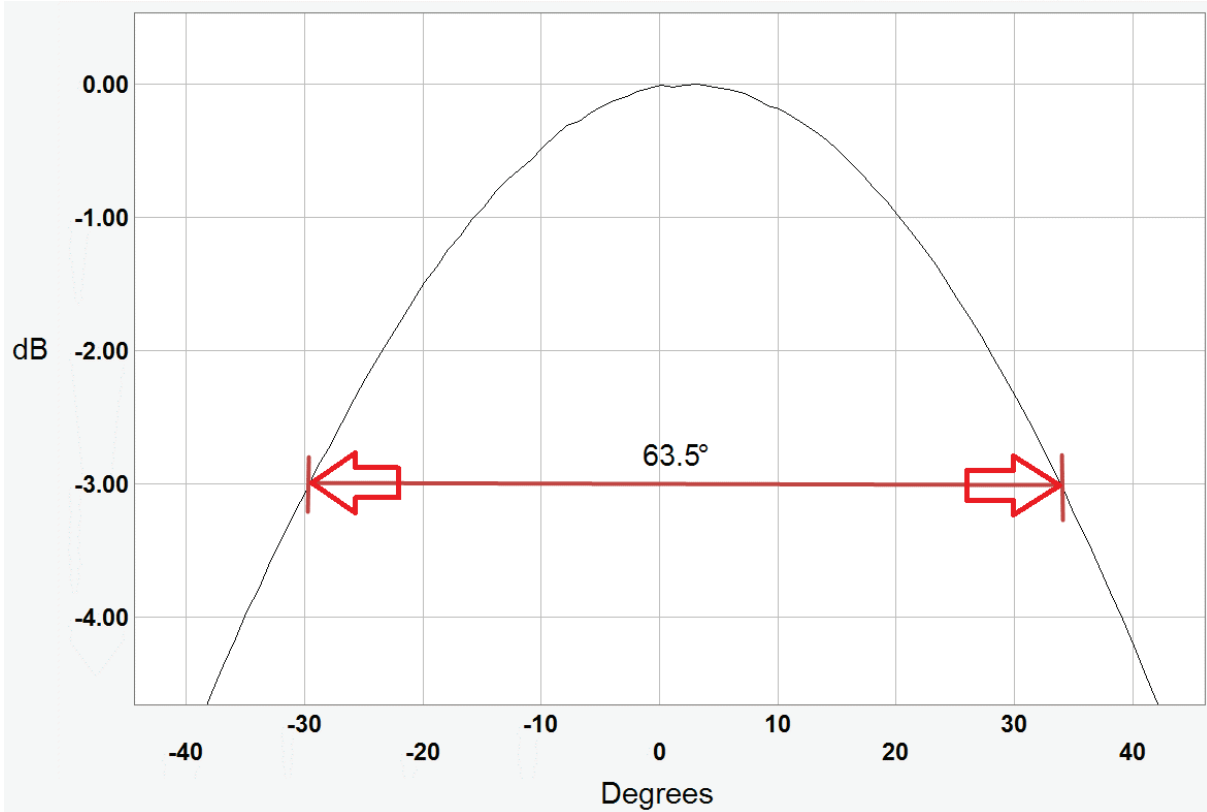

Figure 6—Calculation of azimuth beamwidth.

Specification Definition

- Typical (mean) value in degrees.
- Tolerance in degrees.
- This is a double-sided statistical parameter.
- The beamwidth is calculated from the co-polar pattern.
- This parameter is to be defined for the nominal sub-bands in a broadband antenna. It will be assumed that the specification is valid for the full electrical downtilt range, and for all the ports associated with each frequency sub-band of the antenna.
- For omnidirectional antennas, this parameter shall not be given.

Specification Example

<i>Type: Statistical</i>	1710-1880 MHz	1850-1990 MHz	1920-2170 MHz
Azimuth Beamwidth	67.9 ± 1.9	65.0 ± 1.6	63.5 ± 2.3

XML - Tag Example

```
<azimuth_beamwidth value="67.9" tolerance="1.9"/>
```

Relevance

- This beam parameter indicates the sector coverage provided by a BSA.

- BSAs are typically referred to by their nominal azimuth beamwidth, for example, a 65° BSA.
- Nominal requirements are usually but not limited to, 90° or 65° for 3 sector cell sites, and 45° or 33° for 6 sector sites.

3.2.6 Elevation Beamwidth

Parameter Definition

- The 3 dB (or half-power) elevation beamwidth of the antenna is defined in the elevation radiation pattern as the angular width including the main beam peak, which extends between the only two points at a beam level 3 dB lower than the maximum of radiation, which are also the nearest to the main beam peak.

Specification Definition

- Typical (mean) value in degrees.
- Tolerance in degrees.
- This is a double-sided statistical parameter.
- The beamwidth is calculated from the co-polar pattern.
- This parameter is to be defined for the nominal sub-bands in a broadband antenna. It will be assumed that the specification is valid for the full electrical downtilt range, and for all the ports associated with each frequency sub-band of the antenna.

Specification Example

<i>Type: Statistical</i>	1710-1880 MHz	1850-1990 MHz	1920-2170 MHz
Elevation Beamwidth	7.6 ± 0.4	7.0 ± 0.3	6.6 ± 0.5

XML - Tag Example

```
<elevation_beamwidth value="6.6" tolerance="0.5"/>
```

Relevance

- One of the parameters contributing to the characteristics and extent of the cell sector coverage.

3.2.7 Electrical Downtilt Range

Parameter Definition

- For an antenna capable of variable electrical tilt, the nominal range of angles defined by the minimum and maximum electrical tilt settings. For a fixed electrical tilt antenna, the only possible nominal angle.

Specification Definition

- For a fixed electrical tilt antenna, the nominal value in degrees.
- For a variable electrical tilt antenna, the nominal range of values in degrees.
- For omnidirectional antennas, this parameter shall be referenced to the nominal angle between the horizontal cut and the beam peak axis.

Specification Example

- For a variable tilt antenna:

<i>Type: Nominal</i>	1710-2170 MHz
Electrical downtilt	0-10

- For a fixed tilt antenna:

<i>Type: Nominal</i>	1710-2170 MHz
Electrical downtilt	4

XML - Tag Example

```
<electrical_downtilt start="0" stop="10"/>
<electrical_downtilt start="4" stop="4"/>
```

Relevance

- One of the parameters contributing to the characteristics and extent of the cell sector coverage.
- The setting of electrical tilt is commonly adjusted for RF coverage and interference optimization.
- A parameter that can be adjusted for cell load balancing.

3.2.8 Elevation Downtilt Deviation

Parameter Definition

- Maximum deviation of the actual elevation downtilt from the nominal elevation downtilt value.

Specification Definition

- Specified as a maximum value in degrees referenced to nominal tilt value.
- This is a single-sided statistical parameter – its validation is a special case.
- It is measured from the Co-Pol pattern.
- The reference for the elevation beam peak is the mechanical boresight.
- The reference for the nominal tilt setting the elevation downtilt indicator.
- Section 4.7 addresses the statistical validation of the electrical downtilt deviation.
- This parameter is to be defined for the nominal sub-bands in a broadband antenna. It will be assumed that the specification is valid for the full electrical downtilt range, and for all the ports associated with each frequency sub-band of the antenna.
- For omnidirectional antennas, this parameter shall be referenced to the difference between nominal and actual angle between the horizontal cut and the beam peak axis.

Specification Example

<i>Type: Statistical</i>	1710-1880 MHz	1850-1990 MHz	1920-2170 MHz
Elevation Downtilt Deviation	< 0.5	< 0.4	< 0.4

XML - Tag Example

```
<elevation_downtilt_deviation value="0.5"/>
```

Relevance

- A measure of the accuracy of electrical tilt settings.

3.2.9 Impedance

Parameter Definition

- The characteristic impedance is the ratio between voltage and current flowing into an infinite length transmission line. Validity of this definition is limited to TEM modes (i.e., fundamental modes of coaxial cable). For an antenna the impedance is defined at its inputs (typically its ports).

Specification Definition

- The characteristic impedance nominal value in Ohms.

Specification Example

<i>Type: Nominal</i>	1710-2170 MHz
Impedance	50

XML - Tag Example

```
<impedance value="50"/>
```

Relevance

- Base station antennas are typically specified to have a characteristic impedance of 50 Ohm.
- The VSWR (see below) specification parameter measures the antenna mismatch with respect to characteristic impedance.

3.2.10 Voltage Standing Wave Ratio

Parameter Definition

- The VSWR is defined as the highest ratio between the cluster ports of the maximum and minimum amplitudes of the voltage standing wave measured at the input ports of an antenna.

Specification Definition

- VSWR is an absolute parameter.
- Specified as a maximum in-band value without measurement unit. All the possible values lie is between 1 (no reflection) and infinite (total reflection). The reference wave impedance is 50 Ohms.
- Specification shall reference the full frequency range, full electrical downtilt range, and associated ports of the antenna.

Specification Example

Type: Absolute	1710-2170 MHz
Voltage Standing Wave Ratio	< 1.5

XML - Tag Example

<vswr value="1.5"/>

Relevance

- The VSWR is a measure of the matching of the antenna’s radiators to its source and feeder cables. A low VSWR will minimize reflections from the antenna.

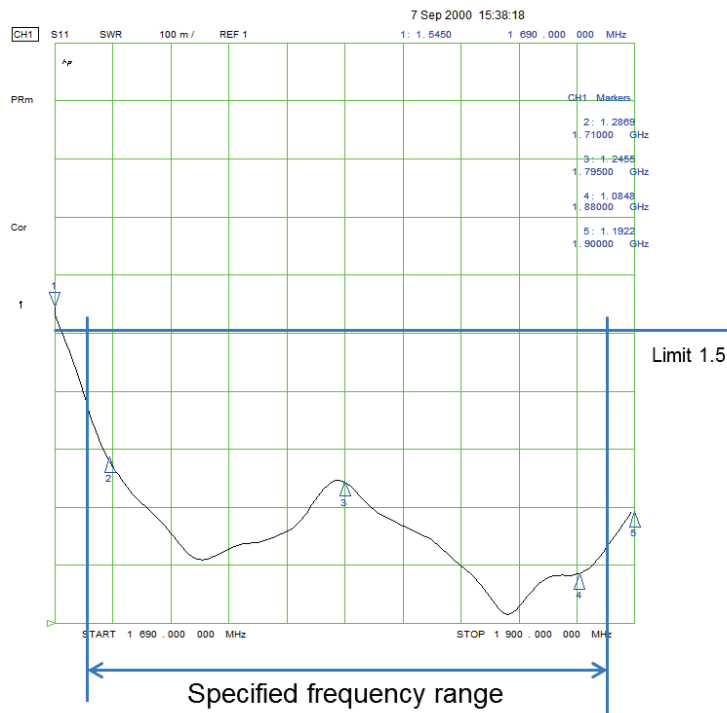

Figure 7—Example of VSWR measurement of an antenna port.

3.2.11 Return Loss

Parameter Definition

- The RL is the measure of the difference between forward and reflected power measured at the antenna port over the stated operating band.

Specification Definition

- Return loss is an absolute parameter.
- Specified as a maximum in-band value in dB.

- Specification shall reference the full frequency range, full electrical downtilt range, and associated ports of the antenna.

Specification Example

Type: Absolute	1710-2170 MHz
Return Loss	> 14

XML - Tag Example

<return_loss value="14.0"/>

Relevance

- One of the indicators of the effectiveness of the power delivery from an antenna’s input to an antenna’s radiated output (a higher RL value represents less reflections from the antenna).
- Return loss and VSWR both characterize the mismatch between the transmission line and the antenna’s radiators and are mathematically related though the following formula:

$$RL[dB] = 20 * \log_{10} \left(\frac{VSWR + 1}{VSWR - 1} \right)$$

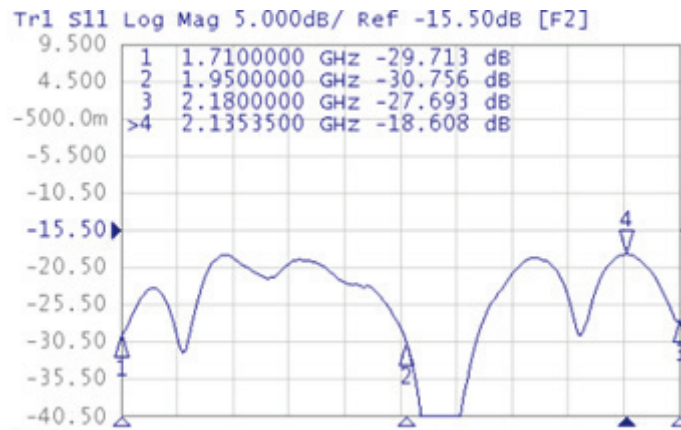

Figure 8—Example of a return loss measurement on a single antenna port.

3.2.12 Cross-Polar Isolation

Parameter Definition

- It is within a cluster the ratio of the power injected in one of the ports associated to a specific polarization, and the power detected from the other port associated to the polarization orthogonal to the first one.

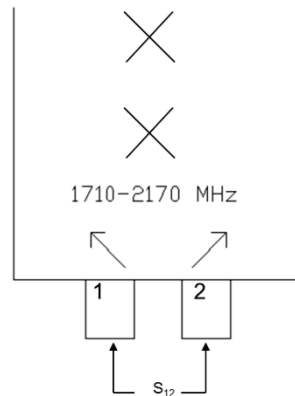
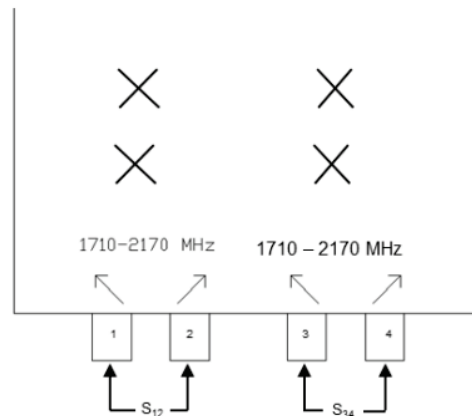

Figure 9—Cross-polar isolation example: single cluster antenna.



In this dual cluster example, the cross-polar isolation is the S_{12} for the first cluster and S_{34} for the second cluster.

Figure 10—Cross-polar isolation example: dual cluster antenna.

Specification Definition

- Cross-Polar Isolation is a minimum absolute parameter.
- Specified in dB.
- This parameter is to be defined for all the sub-bands in a broadband antenna. It will be assumed the specification is for the full electrical downtilt range, and for all the ports associated with each frequency sub-band of the antenna.
- For antennas with multiple dual-pol clusters, the specification applies to each cluster individually and does not address coupling between them.
- Coupling between individual ports is best described in terms of “S parameters”. For example, the magnitude in dB of the coupling from port 1 to port 2 is signified by S_{12} .
- For passive BSAs coupling is reciprocal, i.e., $S_{12} = S_{21}$.

Specification Example

Type: Absolute	1710-1880 MHz	1850-1990 MHz	1920-2170 MHz
Cross-Polar Isolation	> 30	> 28	> 26

XML - Tag Example

```
<isolation_cross_polar value="26"/>
```

Relevance

- Coupling between antenna ports can influence the level of filtering required for a given site configuration.

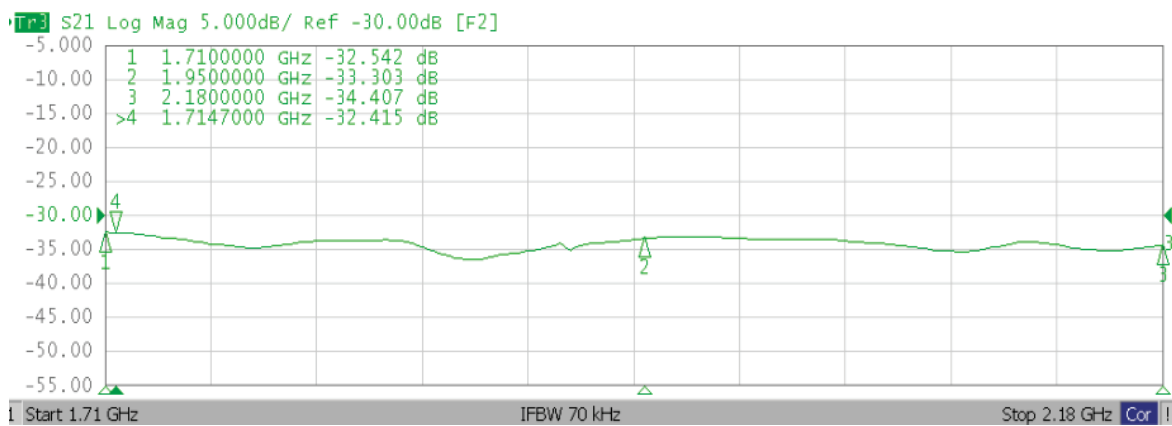

Figure 11—Example of a cross-polar isolation measurement between two antenna ports.

3.2.13 Passive Intermodulation

Parameter Definition

- The PIM is the low level signal created as the result of multiple high power transmit signals in an antenna. This relatively low power signal is generated at distinct frequencies and has the potential to inject interference in the receive band thereby degrading the uplink reception.

Specification Definition

- PIM is an absolute parameter.
- It is specified as a maximum in-band negative value in dBc.
- 3rd order passive intermodulation products measured using 2 x 20W (2 x 43 dBm) carriers (F1 and F2).
- 3rd order products are defined at frequencies of (F1 ± 2*F2) and (F2 ± 2*F1) falling within the receive band when transmit frequencies F1 and F2 are used as the input carriers.
- Specification shall reference the full frequency range, full electrical downtilt range, and associated ports of the antenna.
- PIM measurement practices are discussed in Section 9.5 .

- PIM measurement values shall refer to measurement at the connector in accordance with IEC 62037-6, Passive RF and microwave devices, intermodulation level measurement – Part 6: Measurement of passive intermodulation in antennas.

Specification Example

Type: Absolute	1710-2170 MHz
Passive Intermodulation	< -150

XML - Tag Example

```
<passive_intermodulation value="-150"/>
```

Relevance

- The specification defines a limit to the PIM generated in the antenna, which under the right conditions, causes receive band interference that degrades uplink system sensitivity.

3.2.14 Front-to-Back Ratio, Total Power, ± 30°

Parameter Definition

- The F/B, total power, ± 30°, is defined as the ratio of power gain between the beam peak and the lowest ratio of total power in the rear ±30° angular region of the azimuth cut in respect to the projection of the mechanical boresight backward direction (±180°) onto the azimuth cut as reference.

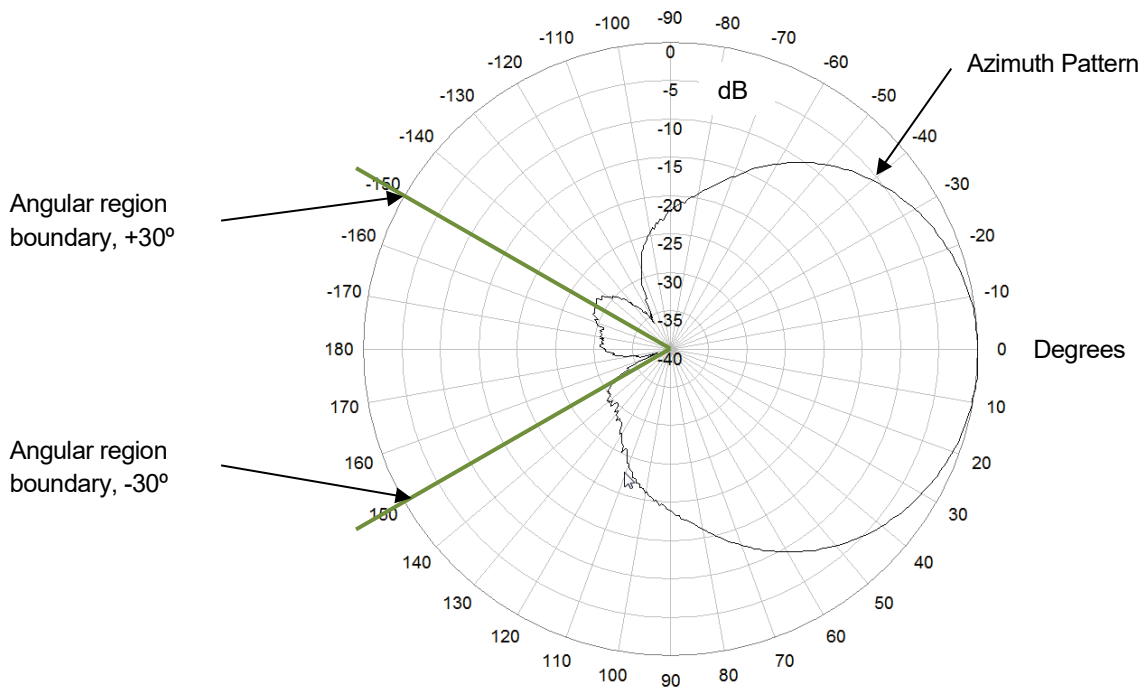

Figure 12—Angular region for front-to-back, total power ± 30° of a 0° mechanical boresight antenna.

Specification Definition

- F/B is specified as a minimum value in dB.
- It is subject to a statistical validation for a single-sided parameter.
- This parameter is to be defined for the nominal sub-bands in a broadband antenna. It will be assumed that the specification is valid for the full electrical downtilt range, and for all the ports associated with each frequency sub-band of the antenna.
- Section 2.6 addresses the total power calculation.
- For omnidirectional antennas, this parameter shall not be given.

Specification Example

<i>Type: Statistical</i>	1710-1880 MHz	1850-1990 MHz	1920-2170 MHz
Front-to-Back Ratio, Total Power, ± 30°	> 25.0	> 26.4	> 25.8

XML - Tag Example

```
<front_to_back_ratio_total_power_pm30 value="26.4"/>
```

Relevance

- A measure of the interference radiated backwards by the antenna into neighboring cells.
- Total power is the root square sum of the linear values of the co-polarized and cross-polarized radiation from an antenna port.

3.2.15 First Upper Sidelobe Suppression

Parameter Definition

- The first upper sidelobe suppression is the gain difference between the main beam peak and the peak of the closest sidelobe above it.

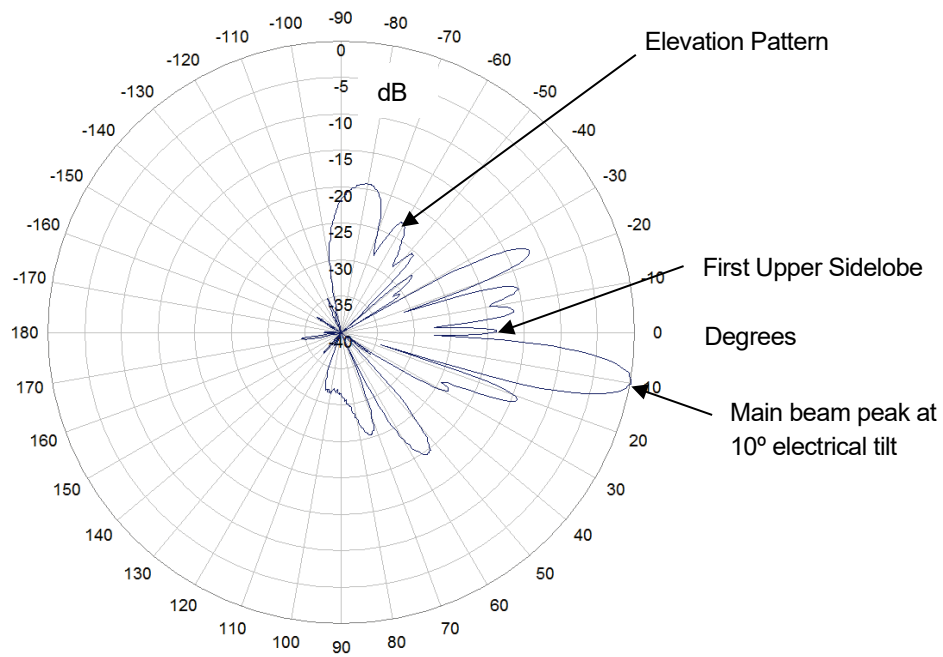

Figure 13—First upper sidelobe suppression.

Specification Definition

- First upper SLS is a maximum value in dB.
- It is subject to a statistical validation for a single-sided parameter.
- This parameter is to be defined for the nominal sub-bands in a broadband antenna. It will be assumed that the specification is valid for the full electrical downtilt range, and for all the ports associated with each frequency sub-band of the antenna.
- Sidelobe detection routines are discussed in Section 9.5 .
- For omnidirectional antennas, this parameter shall be referenced to the cut by the beam peak axis.

Specification Example

<i>Type: Statistical</i>	1710-1880 MHz	1850-1990 MHz	1920-2170 MHz
First Upper Sidelobe Suppression	> 18.6	> 17.8	> 16.2

XML - Tag Example

```
<upper_sidelobe_suppression_first value="18.6"/>
```

Relevance

- Parameter indicating the amount of neighboring cell interference generated by the first sidelobe.
- Positioning of the suppressed upper sidelobe using variable electrical tilt can minimize adjacent cell interference.

3.2.16 Upper Sidelobe Suppression, Peak to 20°

Parameter Definition

- The USLS, peak to 20° is the gain difference between the main beam peak and the maximum of the sidelobes levels in the angular region delimited by the main beam peak and 20 degrees above it.

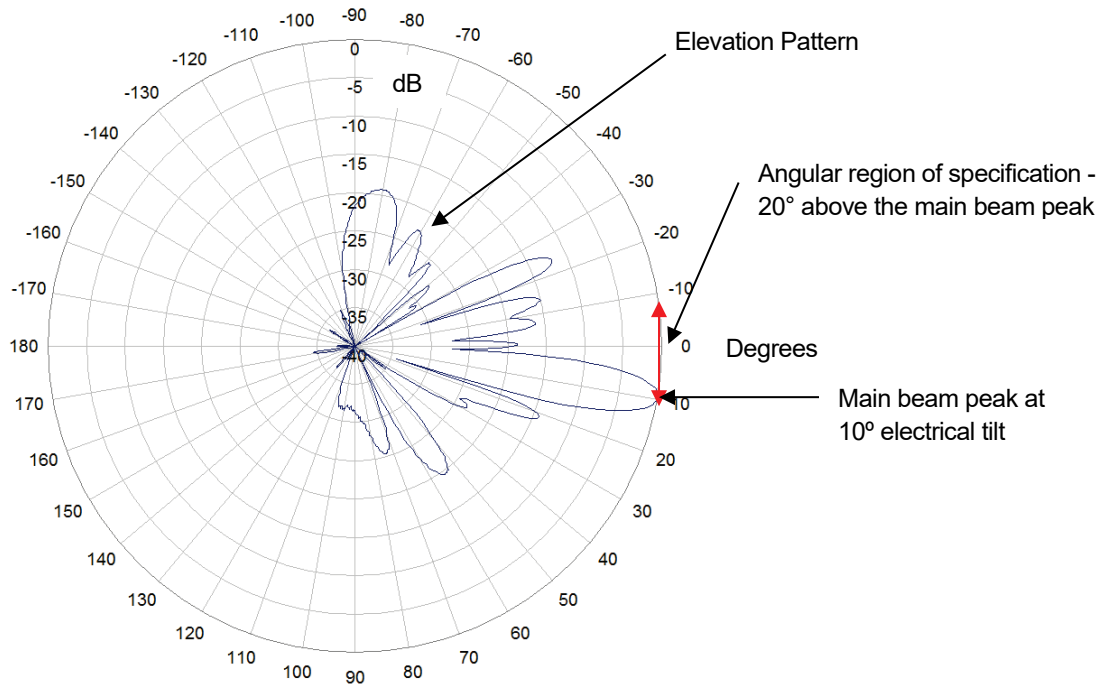

Figure 14—Upper sidelobe suppression, peak to 20°.

Specification Definition

- Upper SLS, peak to 20° is a maximum value in dB.
- It is subject to a statistical validation for a single-sided parameter.
- This parameter is to be defined for the nominal sub-bands in a broadband antenna. It will be assumed that the specification is valid for the full electrical downtilt range, and for all the ports associated with each frequency sub-band of the antenna.
- Sidelobe detection routines are discussed in Section 9.5 .
- For omnidirectional antennas, this parameter shall be referenced to the cut by the beam peak axis.

Specification Example

Type: Statistical	1710-1880 MHz	1850-1990 MHz	1920-2170 MHz
Upper Sidelobe Suppression, Peak to 20°	> 18.6	> 17.8	> 16.2

XML - Tag Example

```
<upper_sidelobe_suppression_peak_to_20 value="16.2"/>
```

Relevance

- Parameter indicating the amount of neighboring cell interference generated by the upper sidelobes.
- Positioning of the suppressed upper sidelobes using variable electrical tilt can minimize adjacent-cell interference.

3.2.17 Cross-Polar Discrimination over Sector

Parameter Definition

- The CPD over sector is defined as the lowest ratio between the co-polar component of a specific polarization and the orthogonal cross-polar component (typically +45° to -45° or vice versa) within the left and right sector boundaries in respect to the projection of the mechanical boresight onto the azimuth cut.

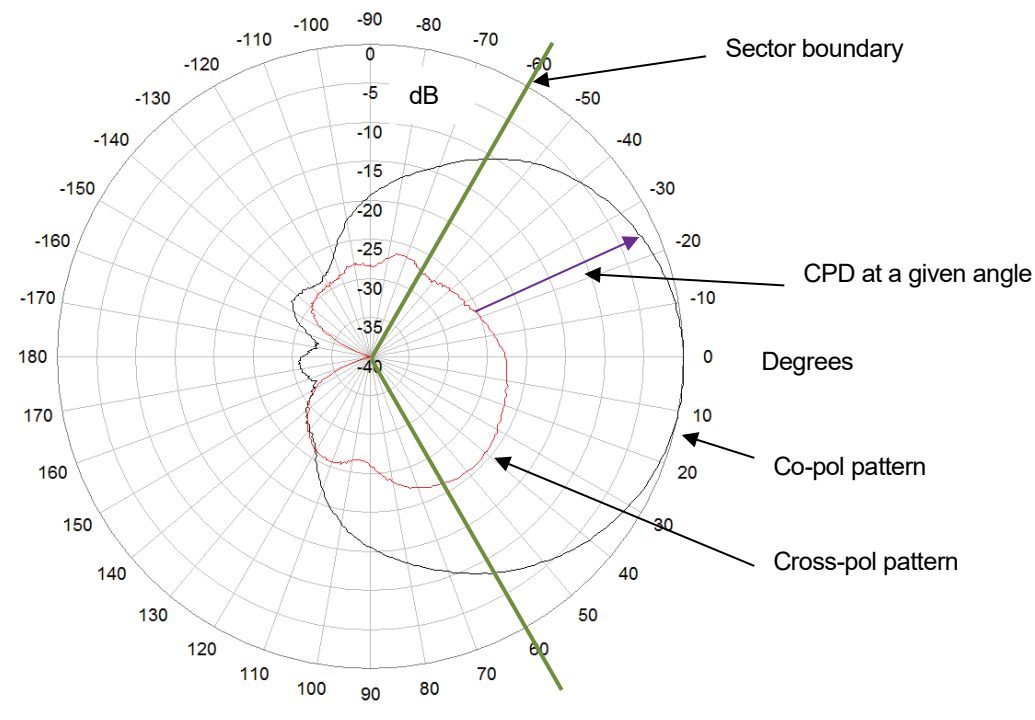

Figure 15—Cross-polar discrimination over sector of a 0° mechanical boresight, 60° nominal horizontal HPBW antenna.

Specification Definition

- CPD is the magnitude of the relative power of the Co-Pol pattern with respect to the Cr-Pol pattern at a given angle.
- The CPD over the sector is the worst case measured in a defined angular deviation from the main beam direction. It will be assumed that the parameter is referenced to the nominal sector associated with the antenna.
- It is subject to a statistical validation for a single-sided parameter.
- For a three sector application the nominal sector is normally defined as 120°. For a six sector application the nominal sector is normally defined 60°.

- This parameter is to be defined for the nominal sub-bands in a broadband antenna. It will be assumed that the specification is valid for the full electrical downtilt range, and for all the ports associated with each frequency sub-band of the antenna.
- For multi-beam antennas type II, this parameter shall be instead defined for each beam as the CPR over the nominal beamwidth of the analyzed beam around the projection of its nominal direction onto the azimuth cut.
- For omnidirectional antennas, this parameter shall be referenced to the whole turn. It shall then be the worst possible case.

Specification Example

<i>Type: Statistical</i>	1710-1880 MHz	1850-1990 MHz	1920-2170 MHz
Cross Polar Discrimination Over Sector	> 10.8	> 9.4	> 8.5

XML - Tag Example

```
<cross_polar_discrimination_over_sector value="10.8"/>
```

Relevance

- CPD is important for a low level of correlation between the orthogonally polarized propagation channels. Correlation generated by the antenna can negatively affect receive diversity and MIMO performance of the system. A minimum level of 8 to 10 dB within the relevant sector is recommended for minimum degradation to receive diversity and MIMO performance.

3.2.18 Maximum Effective Power per Port

Parameter Definition

- The maximum power, which can be transmitted into one antenna port, and which shall be withstood by the antenna without it suffering permanent damage or being mechanically or electrically affected (hence subject to parameters' alteration).

Specification Definition

- Power is defined as effective CW power.
- This is an absolute, maximum parameter specified in Watts.
- It is valid for the operational environmental conditions specified for the antenna.
- Specification shall reference the full frequency range, full electrical downtilt range, and associated ports of the antenna.

Specification Example

<i>Type: Absolute</i>	1710-2170 MHz
Maximum Effective Power per Port	250

XML - Tag Example

```
<maximum_effective_power_per_port value="250"/>
```

Relevance

- Exceeding the specified power rating can damage the antenna.

3.2.19 Maximum Effective Power Whole Antenna

Parameter Definition

- The maximum total power, which can be transmitted into the antenna, and which shall be withstood by the antenna itself without it suffering permanent damage or being mechanically or electrically affected (hence subject to parameters' alteration).

Specification Definition

- Power is defined as effective CW power.
- This is an absolute, maximum parameter specified in Watts.
- It is valid for the operational environmental conditions specified for the antenna.
- Specification shall reference all the frequency ranges, the full electrical downtilt range, and all the ports of the antenna.

Specification Example

<i>Type: Absolute</i>	
Maximum Effective Power Whole Antenna	1200

XML - Tag Example

```
<maximum_effective_power_antenna value="1200"/>
```

Relevance

- Exceeding the specified power rating can damage the antenna.

3.2.20 Interband Isolation

Parameter Definition

- The worst coupling case between a port of a specific cluster and any other port of another cluster in a multiple band, or broad band antenna.

Specification Definition

- Interband isolation is an absolute minimum parameter specified in dB.
- Coupling between individual ports is best described in terms of "S parameters". For example, the magnitude in dB of the coupling from port 1 to port 3 is signified by S_{13} .
- For passive devices, coupling is reciprocal, that is, $S_{13} = S_{31}$.
- Specification shall reference the full frequency range, full electrical downtilt range, and associated ports of the antenna.

Specification Example

Type: Absolute	1710-2170 MHz
Interband Isolation	> 20

XML - Tag Example

<isolation_interband value="20"/>

Relevance

- Coupling between antenna ports can influence the level of filtering required for a given site configuration.

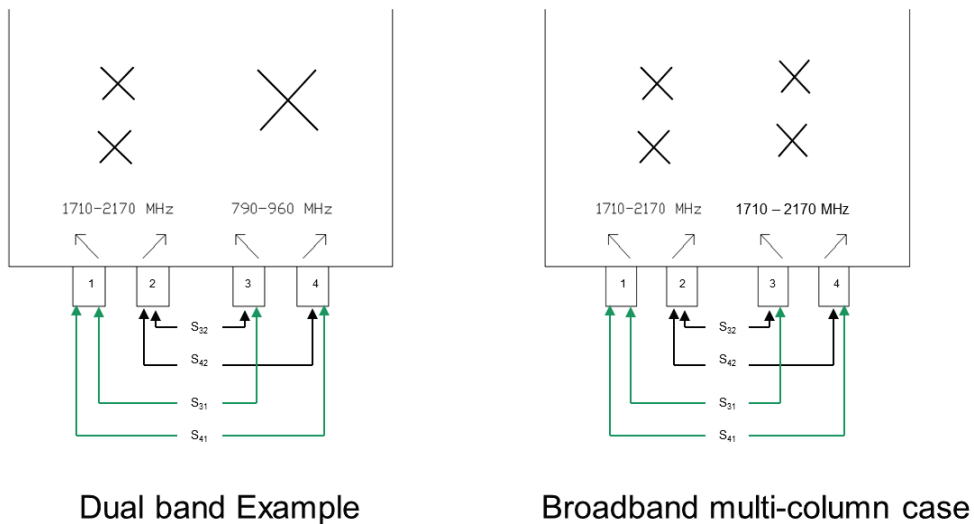

Dual band Example

Broadband multi-column case

Figure 16—Interband isolation examples. In this example, the interband isolation is the worst case of S41, S31, S42 and S32.

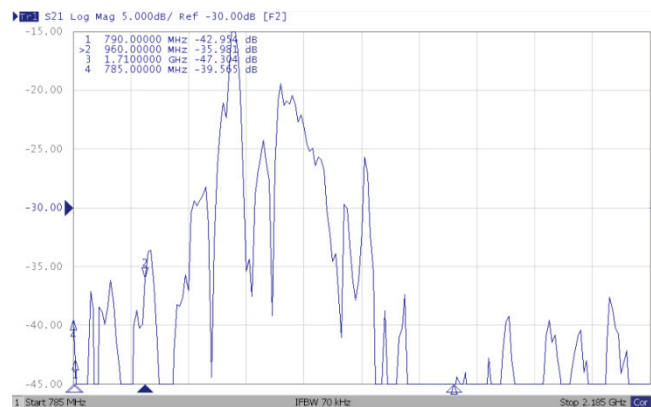

Figure 17—Interband isolation vs. frequency on a single pair of ports.

3.3 Optional RF Parameters

3.3.1 Front-to-Back Ratio over 30° Angular Region - Total Power Azimuth & Elevation

Parameter Definition

- The F/B over 30° angular region - total power AZ & EL is defined as the ratio of power gain between the beam peak and the lowest ratio of total power in the rear $\pm 30^\circ$ angular region of the azimuth and elevation, in respect to the projection of the mechanical boresight backward direction ($\pm 180^\circ$) onto the azimuth cut and the horizon as reference.

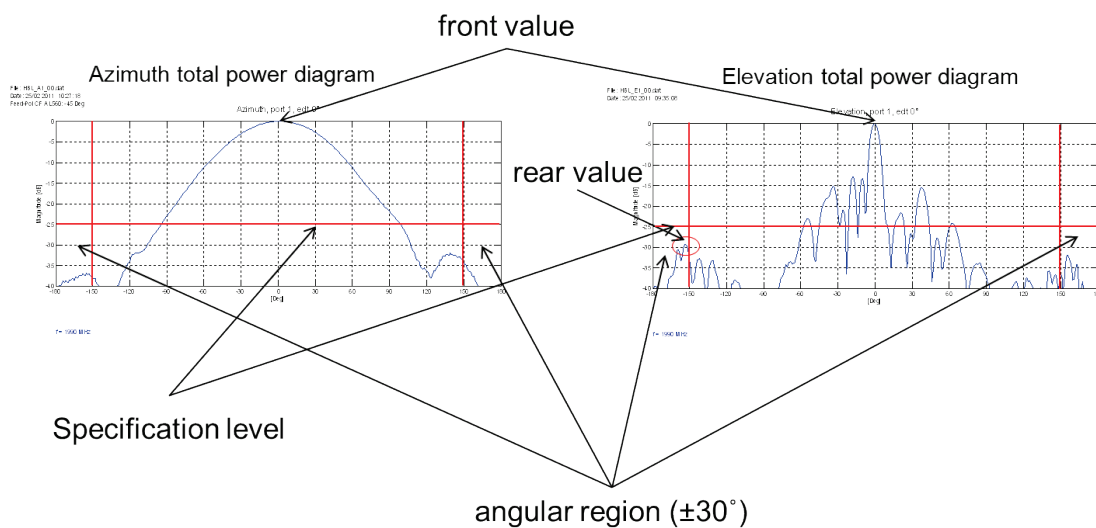

Figure 18—F/B angular regions, azimuth and elevation.

Specification Definition

- F/B is specified as a minimum value in dB.
- It is subject to a statistical validation for a single-sided parameter.
- This parameter is to be defined for the nominal sub-bands in a broadband antenna. Unless otherwise noted it will be assumed the specification is for the full electrical downtilt range, and for all the ports associated with each frequency sub-band of the antenna.
- Section 2.6 addresses the total power calculation.
- For omnidirectional antennas, this parameter shall not be given.

Specification Example

Type: Statistical	1710-1880 MHz	1850-1990 MHz	1920-2170 MHz
Front-to-Back Ratio over 30° Angular Region - Total Power AZ & EL	> 25.0	> 26.4	> 25.8

XML - Tag Example

```
<front_to_back_ratio_over_30_angular_region_total_power_az_and_el value="25.0"/>
```

Relevance

- An indicator of the interference radiated backwards by the antenna into neighboring cells.
- Total power is the root square sum of the linear values of the co-polarized and cross-polarized radiation from an antenna port.
- There is always a back lobe, which is generally broad in the azimuth plane and narrow in the elevation plane as is the main beam. It also generally has the same electrical tilt angle as the main beam.

3.3.2 Azimuth Beam Squint

Parameter Definition

- The azimuth beam squint is the difference in the azimuth cut between the pointing direction of the main beam and the antenna’s projection of mechanical boresight onto the azimuth cut. The pointing direction of the main beam is defined as the half-power beamwidth bisect.

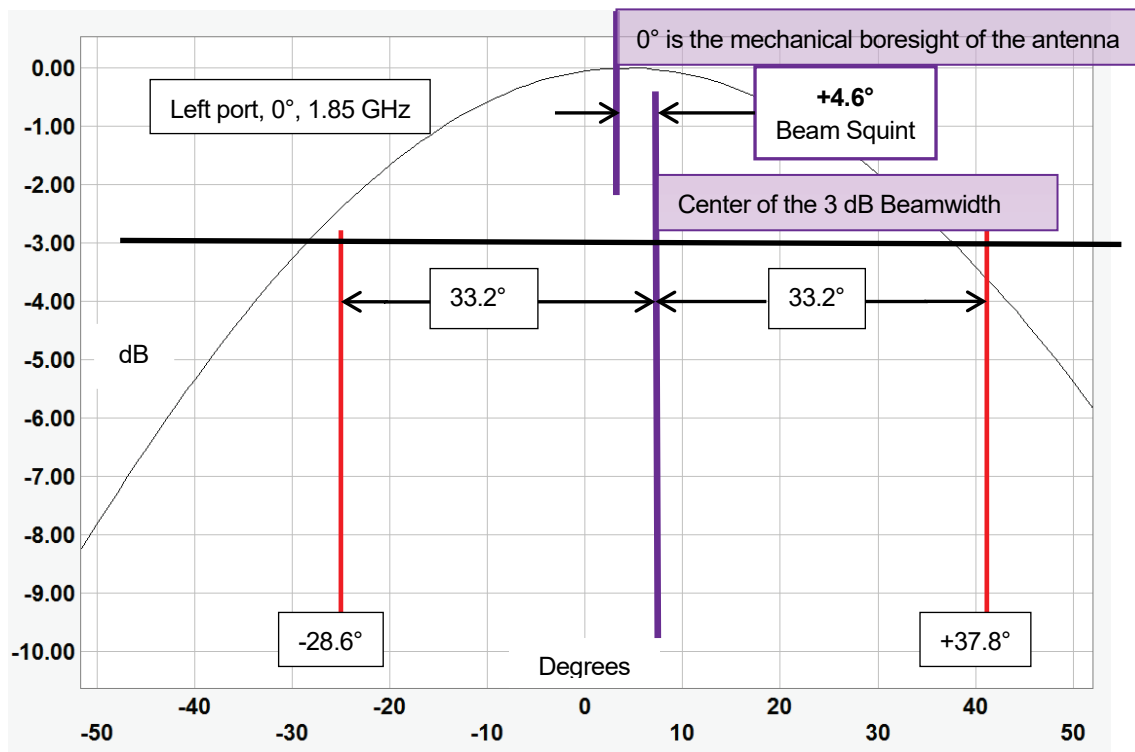

Figure 19—Illustration of beam squint calculation for a given frequency, tilt and port.

Specification Definition

- Typical (mean) value in degrees.
- Tolerance in degrees.
- It is subject to a statistical validation for a double-sided parameter.
- Squint is measured from the co-polar pattern.
- This parameter is to be defined for the nominal sub-bands in a broadband antenna. It will be assumed that the specification is valid for the full electrical downtilt range, and for all the ports associated with each frequency sub-band of the antenna.

- For multi-beam antennas type II, this parameter shall be instead defined for each beam, as the difference in the azimuth cut between the pointing direction (defined as the half-power beamwidth bisect) of the analyzed beam and the projection of its nominal direction onto the azimuth cut.
- For omnidirectional antennas, this parameter shall not be given.

Specification Example

<i>Type: Statistical</i>	1710-1880 MHz	1850-1990 MHz	1920-2170 MHz
Azimuth Beam Squint	1.1 ± 2.4	2.7 ± 2.7	2.6 ± 2.6

XML - Tag Example

```
<azimuth_beam_squint value="2.7" tolerance="2.7"/>
```

Relevance

- The half-power beamwidth bisect approach for defining the squint is, in many cases, a better metric than using the beam peak axis, as the first one outlines the centering of the whole half power region of the antenna beam. This is especially relevant for asymmetrical beams. Also, for a beam that has ripples across the center, its axis can be difficult to identify. Beam ripples and asymmetry can especially occur on multi-cluster antennas.
- Excessive azimuth beam squint can impact cell performance near its sectors' boundaries.
- Beams may squint as a function of electrical downtilt.
- Beams may squint due to asymmetries in the antenna architecture, for example, asymmetries in multi-cluster antennas.

3.3.3 Null Fill

Parameter Definition

- The null fill is the pattern level of the first relative minimum below the main beam. This “null” is defined as the point of minimum between the main beam and the first sidelobe below it.

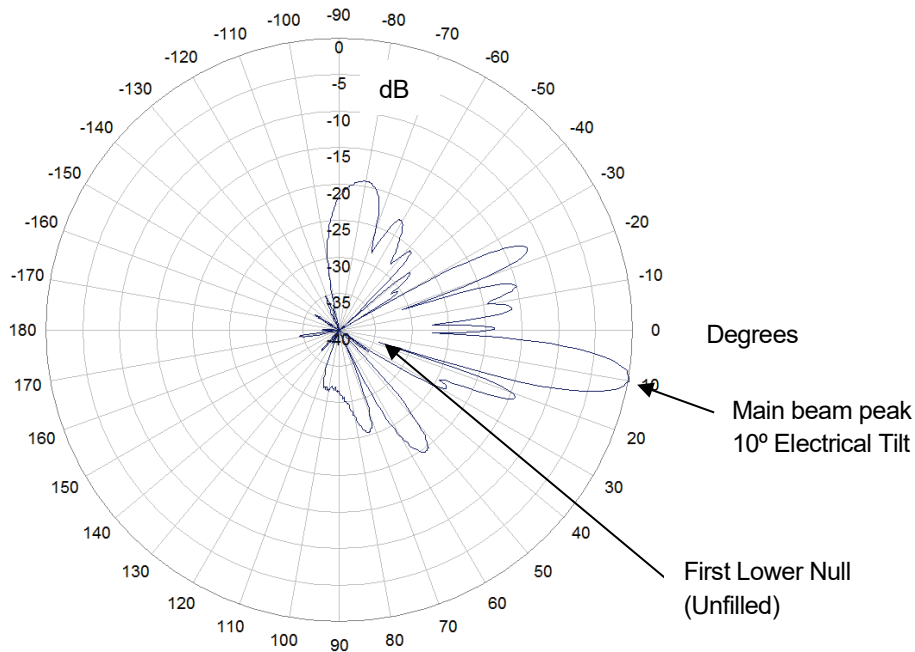

Figure 20—Identification of the lower first null.

Specification Definition

- Null fill is a minimum value in dB.
- It is subject to a statistical validation for a single-sided parameter.
- This parameter is to be defined for the nominal sub-bands in a broadband antenna. It will be assumed that the specification is valid for the full electrical downtilt range, and for all the ports associated with each frequency sub-band of the antenna.
- Since the null fill depends from the first lower sidelobe, its detection routines are discussed with the sidelobes’ ones in Section 9.5 .
- For omnidirectional antennas, this parameter shall be referenced to the cut by the beam peak axis.

Specification Example

Type: Statistical	1710-1880 MHz	1850-1990 MHz	1920-2170 MHz
Null Fill	< 30.2	< 30.3	< 30.3

XML - Tag Example

```
<null_fill value="30.2"/>
```

Relevance

- Null fill is, in most BSA site scenarios, a non-critical parameter due to multipath in the environment and power levels near the cell site.
- Pattern shaping methods are sometimes applied to fill the lower null.
- It can affect the coverage close to base stations with high antenna positions where the null illumination may fall on distances from the antenna where the path loss is sufficient to create coverage holes, and scattering is insufficient to create secondary illumination from the lobes..

3.3.4 Cross-Polar Discrimination at Mechanical boresight

Parameter Definition

- The CPD at mechanical boresight is defined as the ratio of the azimuthal Co-Pol component of a specific polarization to the orthogonal Cr-Pol component (typically +45° to -45° or vice versa) along the projection of the mechanical boresight onto the azimuth cut.

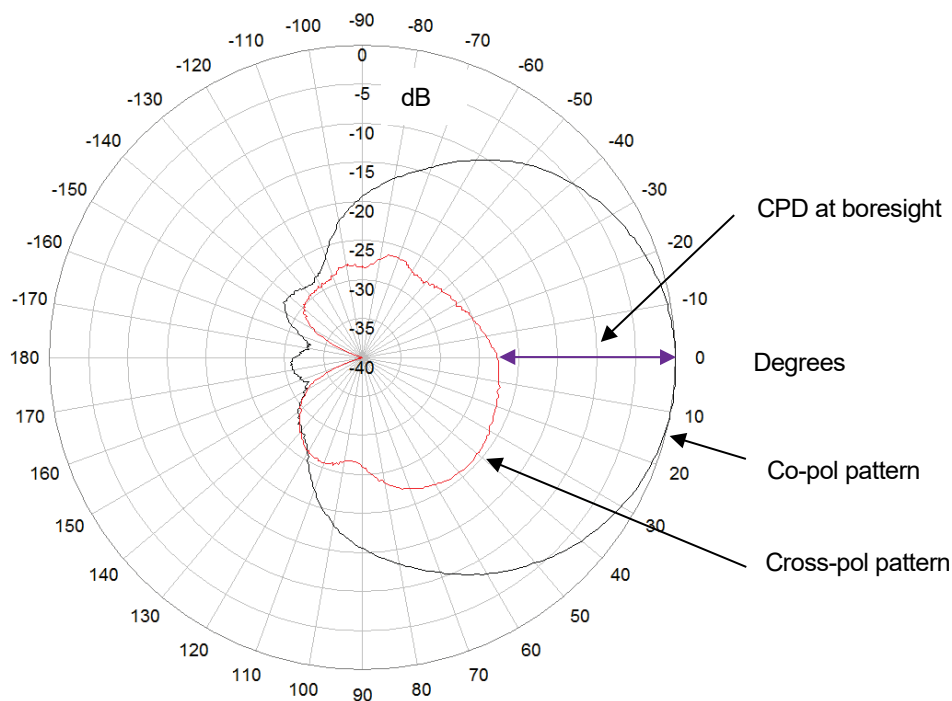

Figure 21—Cross-polar discrimination at mechanical boresight.

Specification Definition

- CPD at mechanical boresight is specified as a minimum value in dB.
- It is subject to a statistical validation for a single-sided parameter.
- This parameter is to be defined for the nominal sub-bands in a broadband antenna. It will be assumed that the specification is valid for the full electrical downtilt range, and for all the ports associated with each frequency sub-band of the antenna.
- For multi-beam antennas type II, this parameter shall be instead defined for each beam, as the CPR of the analyzed beam in respect to the projection of its nominal direction onto the azimuth cut.
- For omnidirectional antennas, this parameter shall not be given.

Specification Example

Type: Statistical	1710-1880 MHz	1850-1990 MHz	1920-2170 MHz
Cross Polar Discrimination at Mechanical boresight	> 25.4	> 22.1	> 26.3

XML - Tag Example

<cross_polar_discrimination_at_mechanical_boresight value="25.4"/>

Relevance

- CPD is important for a low level of correlation between the orthogonally polarized propagation channels. Correlation generated by the antenna can negatively affect receive diversity and MIMO downlink performance of the system.

3.3.5 Cross-Polar Discrimination over 3 dB Azimuth Beamwidth

Parameter Definition

- The CPD over 3 dB azimuth beamwidth is defined as the lowest ratio between the co-polar component of a specific polarization and the orthogonal cross-polar component (typically +45° to -45° or vice versa) within the half-power angular region (between the -3 dB levels of the antenna pattern nearest to the beam peak) in the azimuth cut.

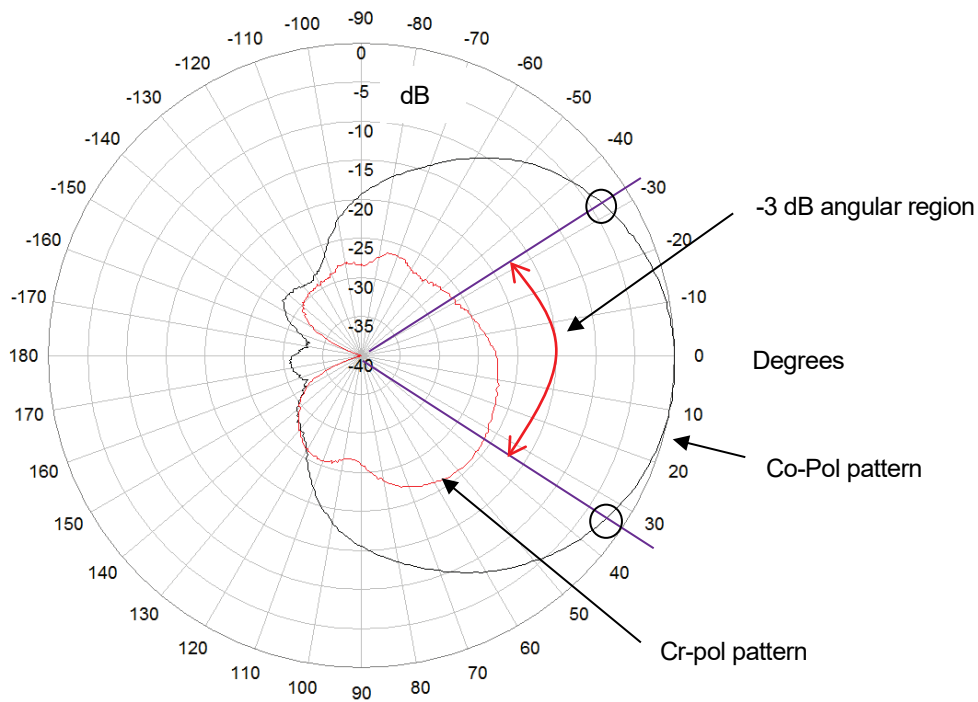

Figure 22—Cross pol discrimination over 3 dB azimuth beamwidth.

Specification Definition

- CPD over 3 dB azimuth beamwidth is specified as a minimum value in dB.
- It is subject to a statistical validation for a single-sided parameter.
- This parameter is to be defined for the nominal sub-bands in a broadband antenna. It will be assumed that the specification is valid for the full electrical downtilt range, and for all the ports associated with each frequency sub-band of the antenna.
- For omnidirectional antennas, this parameter shall not be given.

Specification Example

<i>Type: Statistical</i>	1710-1880 MHz	1850-1990 MHz	1920-2170 MHz
Cross-Polar Discrimination over 3 dB Azimuth Beamwidth	> 11.8	> 16.3	> 14.6

XML - Tag Example

```
<cross_polar_discrimination_over_3_db_azimuth_beamwidth value="XXX"/>
```

Relevance

- CPD is important for a low level of correlation between the orthogonally polarized propagation channels. Correlation generated by the antenna can negatively affect receive diversity and MIMO downlink performance of the system.

3.3.6 Cross-Polar Discrimination over 10 dB Azimuth Beamwidth

Parameter Definition

- The CPD over 10 dB azimuth beamwidth is defined as the lowest ratio between the co-polar component of a specific polarization and the orthogonal cross-polar component (typically +45° to -45° or vice versa) within the half-power angular region (between the -10 dB levels of the antenna pattern nearest to the beam peak) in the azimuth cut.

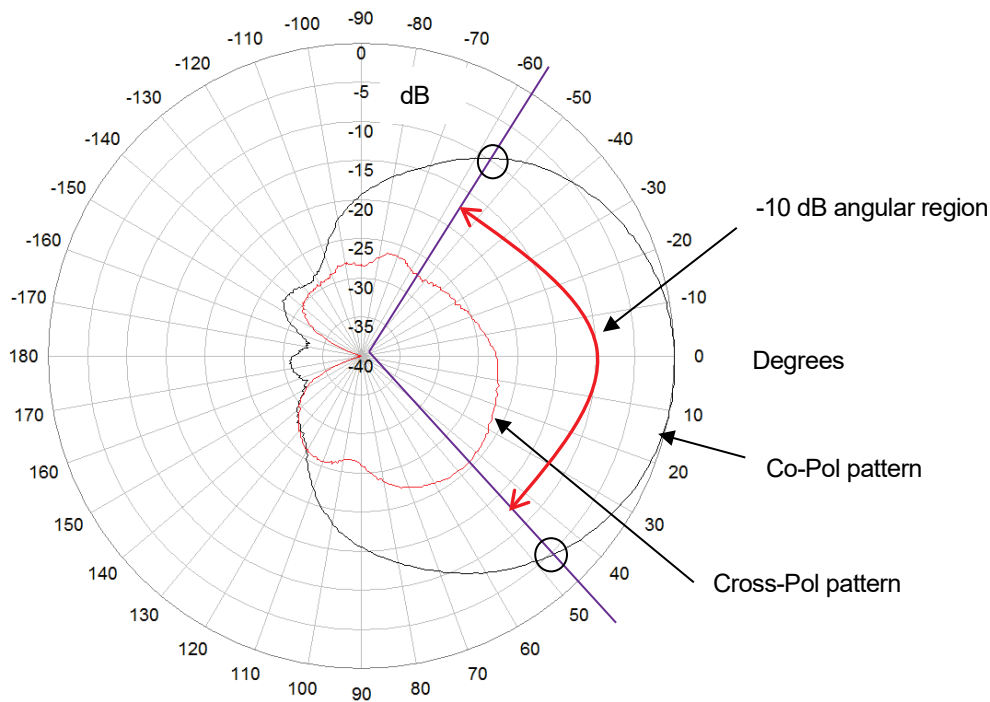

Figure 23—Cross pol discrimination over 10 dB azimuth beamwidth.

Specification Definition

- CPD over 10 dB azimuth beamwidth is specified as a minimum value in dB.
- It is subject to a statistical validation for a single-sided parameter.
- This parameter is to be defined for the nominal sub-bands in a broadband antenna. It will be assumed that the specification is valid for the full electrical downtilt range, and for all the ports associated with each frequency sub-band of the antenna.
- For omnidirectional antennas, this parameter shall not be given.

Specification Example

<i>Type: Statistical</i>	1710-1880 MHz	1850-1990 MHz	1920-2170 MHz
Cross Polar Discrimination over 10 dB Beamwidth	> 11.8	> 13.4	> 12.2

XML - Tag Example

```
<cross_polar_discrimination_over_10_db_beamwidth value="11.8"/>
```

Relevance

- CPD is important for a low level of correlation between the orthogonally polarized propagation channels. Correlation generated by the antenna can negatively affect receive diversity and MIMO downlink performance of the system.

3.3.7 Cross Polar Discrimination over 3 dB Elevation Beamwidth

Parameter Definition

- The CPD over 3 dB elevation beamwidth is defined as the lowest ratio between the co-polar component of a specific polarization and the orthogonal cross-polar component (typically +45° to -45° or vice versa) within the half-power angular region (between the -3 dB levels of the antenna pattern nearest to the beam peak) in the elevation cut.

Specification Definition

- CPD over the 3 dB elevation beamwidth is specified as a minimum value in dB.
- It is subject to a statistical validation for a single-sided parameter.
- This parameter is to be defined for the nominal sub-bands in a broadband antenna. It will be assumed that the specification is valid for the full electrical downtilt range, and for all the ports associated with each frequency sub-band of the antenna.
- For omnidirectional antennas, this parameter shall be referenced to the cut by the beam peak axis.

Specification Example

<i>Type: Statistical</i>	1710-1880 MHz	1850-1990 MHz	1920-2170 MHz
Cross Polar Discrimination over the 3 dB Elevation Beamwidth	> 11.3	> 10.7	> 9.8

XML - Tag Example

```
<cross_polar_discrimination_over_3_db_elevation_beamwidth value="11.3"/>
```

Relevance

- CPD is important for a low level of correlation between the orthogonally polarized propagation channels. Correlation generated by the antenna can negatively affect receive diversity and MIMO downlink performance of the system.

3.3.8 Cross Polar Discrimination over 10 dB Elevation Beamwidth

Parameter Definition

- The CPD over 10 dB elevation beamwidth is defined as the lowest ratio between the co-polar component of a specific polarization and the orthogonal cross-polar component (typically +45° to -45°

or vice versa) within the half-power angular region (between the -10 dB levels of the antenna pattern nearest to the beam peak) in the elevation cut.

Specification Definition

- CPD over the 10 dB elevation beamwidth is specified as a minimum value in dB.
- It is subject to a statistical validation for a single-sided parameter.
- This parameter is to be defined for the nominal sub-bands in a broadband antenna. It will be assumed that the specification is valid for the full electrical downtilt range, and for all the ports associated with each frequency sub-band of the antenna.
- For omnidirectional antennas, this parameter shall be referenced to the cut by the beam peak axis.

Specification Example

Type: Statistical	1710-1880 MHz	1850-1990 MHz	1920-2170 MHz
Cross Polar Discrimination over the 10 dB Elevation Beamwidth	> 11.0	> 10.2	> 9.8

XML - Tag Example

```
<cross_polar_discrimination_over_10_db_elevation_beamwidth value="11.0"/>
```

Relevance

- CPD is important for a low level of correlation between the orthogonally polarized propagation channels. Correlation generated by the antenna can negatively affect receive diversity and MIMO downlink performance of the system.

3.3.9 Azimuth Beam Port-to-Port Tracking

Parameter Definition

- Azimuth beam port-to-port tracking is the highest ratio between the amplitude of the two antenna Co-Pol polarization branches (e.g.: +45° by port 1 to -45° by port 2) within the sector boundaries.

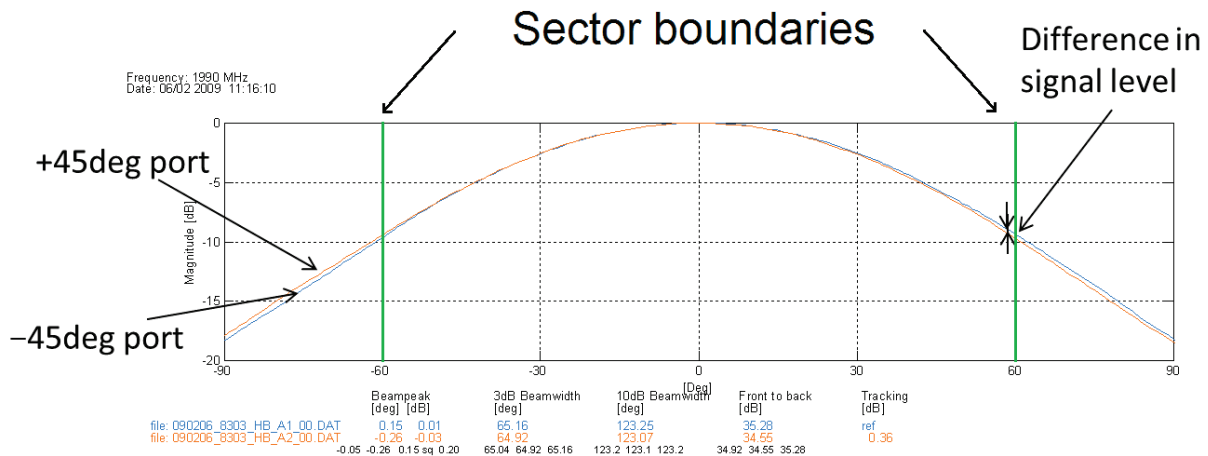

Figure 24—Azimuth beam port-to-port tracking.

Specification Definition

- Azimuth port-to-port tracking is measured within the sector around the projection of mechanical boresight onto the azimuth pattern. It is a Co-Pol pattern measurement.
- Port-to-port tracking is specified as a maximum value in dB.
- It is subject to a statistical validation for a single-sided parameter.
- This parameter is to be defined for the nominal sub-bands in a broadband antenna. It will be assumed that the specification is valid for the full electrical downtilt range, and for all the ports associated with each frequency sub-band of the antenna.
- For omnidirectional antennas, this parameter shall be referenced to the whole turn. This parameter shall then represent the worst possible case.

Specification Example

<i>Type: Statistical</i>	1710-1880 MHz	1850-1990 MHz	1920-2170 MHz
Azimuth Port-to-Port Tracking	< 1.1	< 1.5	< 1.6

XML - Tag Example

```
<azimuth_beam_port_to_port_tracking value="1.6"/>
```

Relevance

- This parameter characterizes the difference in illumination of the cell between two ports of a dual-pol antenna. This difference should be minimized in order to maximize potential diversity gain.

3.3.10 Azimuth Beam H/V Tracking

Parameter Definition

- The azimuth beam H/V tracking is the highest ratio between the signal level of the horizontal and vertical polarization for each port within the sector boundaries.

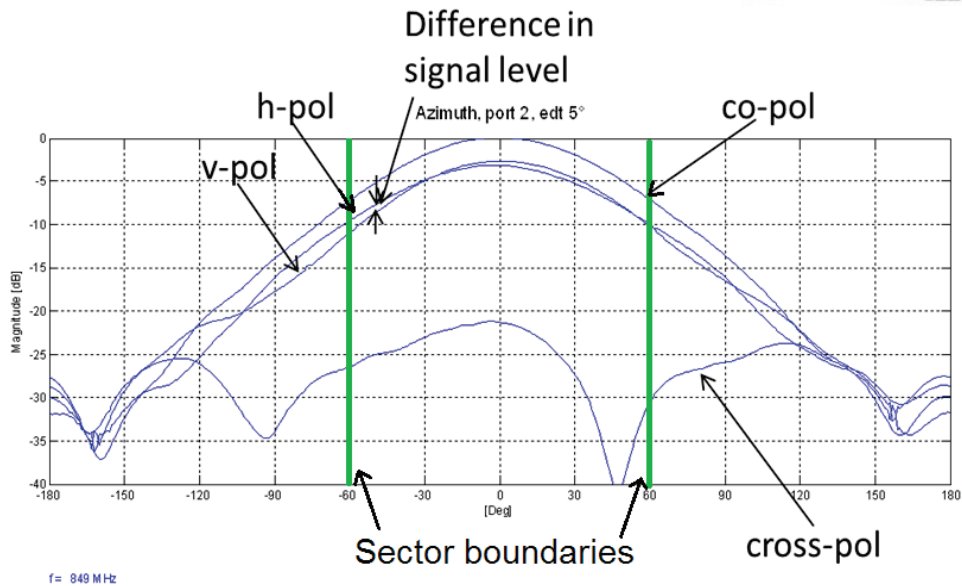

Figure 25—Azimuth beam H/V tracking.

Specification Definition

- Azimuth beam H/V tracking is measured within the sector around the projection of the mechanical boresight onto the azimuth pattern. It is a Co-Pol pattern measurement.
- Azimuth beam H/V tracking is specified as a maximum value in dB.
- It is subject to a statistical validation for a single-sided parameter.
- This parameter is to be defined for the nominal sub-bands in a broadband antenna. It will be assumed that the specification is valid for the full electrical downtilt range, and for all the ports associated with each frequency sub-band of the antenna.
- For multi-beam antennas type II, this parameter shall be instead defined for each beam, as the worst-case ratio between the signal levels of the horizontal and vertical polarization for each port within its nominal beamwidth boundaries (in respect to the projection of mechanical boresight onto the azimuth pattern).
- For omnidirectional antennas, this parameter shall be referenced to the whole turn. This parameter shall then represent the worst possible case.

Specification Example

Type: Statistical	1710-1880 MHz	1850-1990 MHz	1920-2170 MHz
Azimuth H/V Tracking	< 1.8	< 2.2	< 1.6

XML - Tag Example

```
<azimuth_beam_hv_tracking value="2.2"/>
```

Relevance

- This parameters gives an overview on the behavior of an antenna’s polarization over the sector. H and V signal levels are equal when the polarization is exactly $\pm 45^\circ$. Their difference should be minimized in order to maximize polarization diversity gain.

3.3.11 Azimuth Beam Roll-Off

Parameter Definition

- The azimuth beam roll-off is highest difference of the Co-Pol signal levels at the sector edges in respect to the one at the main beam peak.

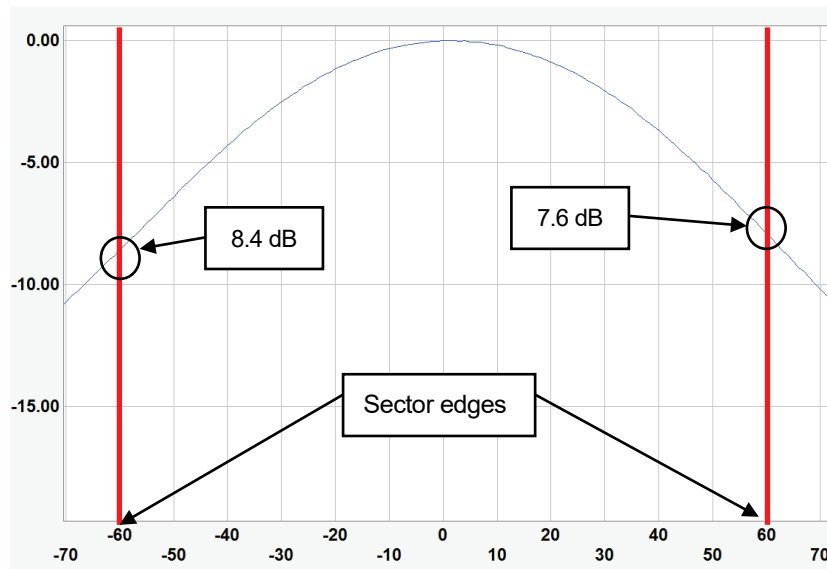

Figure 26—Azimuth beam roll-off.

Specification Definition

- Azimuth beam roll-off is defined as the combination of a typical (mean) value and a tolerance, both in dB.
- It is subject to a statistical validation for a double-sided parameter.
- It is measured at the sector edges around the projection of the mechanical boresight onto the azimuth pattern. It is a Co-Pol pattern measurement.
- This parameter is to be defined for the nominal sub-bands in a broadband antenna. It will be assumed that the specification is valid for the full electrical downtilt range, for all the ports associated with each frequency sub-band of the antenna and for both the sector edges.
- For multi-beam antennas type II, this parameter shall be instead defined for each beam, the signal level at the nominal beamwidth edges (in respect to the projection of mechanical boresight onto the azimuth pattern) of the two antenna Co-Pol polarization branches of the analyzed beam.
- For omnidirectional antennas, this parameter shall not be given.

Specification Example

Type: Statistical	1710-1880 MHz	1850-1990 MHz	1920-2170 MHz
Azimuth Beam Roll-Off	8.1 ± 1.6	9.8 ± 2.3	11.3 ± 2.1

XML - Tag Example

```
<azimuth_beam_roll_off value="11.3" tolerance="2.1"/>
```

Relevance

- This parameter gives an estimate of the power radiated at the sector edges of a cell.
- For a BSA with a given sector, the higher the sector roll-off value, the less interference that is radiated into the adjacent sectors.

3.3.12 Upper Sidelobe Suppression, Horizon to 20°

Parameter Definition

- The USLS, horizon to 20° is the gain difference between the main beam peak and the maximum of the sidelobes levels in the angular region delimited by the horizontal cut (antenna horizon) and the angular direction 20 degrees above it.

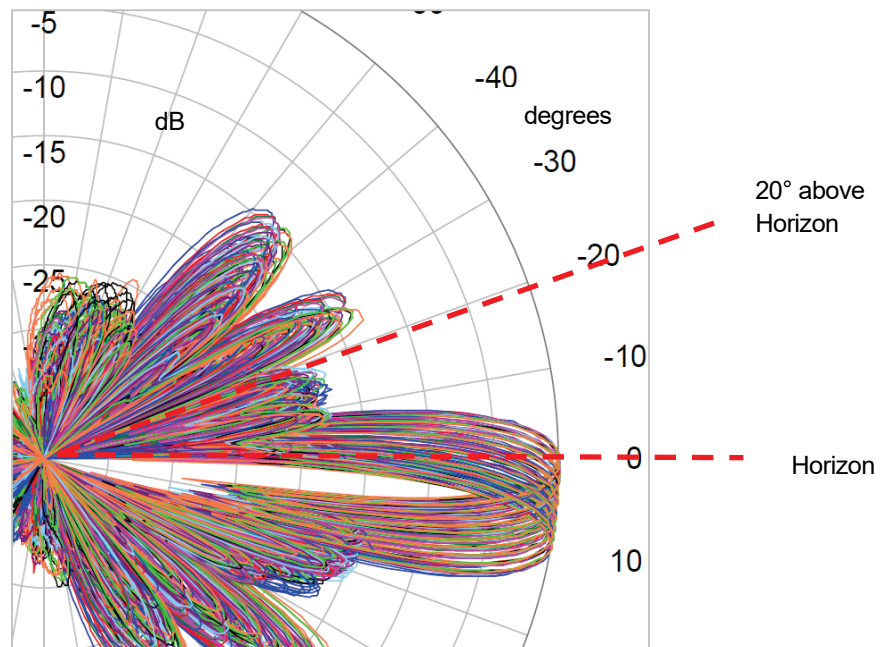

Figure 27—Upper sidelobe suppression, horizon to 20°.

Specification Definition

- The USLS, horizon to 20° is a maximum value in dB.
- It is subject to a statistical validation for a single-sided parameter.
- This parameter is to be defined for the nominal sub-bands in a broadband antenna. It will be assumed that the specification is valid for the full electrical downtilt range, and for all the ports associated with each frequency sub-band of the antenna.
- Sidelobe detection routines are discussed in Section 9.5 .
- For omnidirectional antennas, this parameter shall be referenced to the cut by the beam peak axis.

Specification Example

<i>Type: Statistical</i>	1710-1880 MHz	1850-1990 MHz	1920-2170 MHz
Upper Sidelobe Suppression, horizon to 20°	> 17.6	> 16.6	> 18.4

XML - Tag Example

```
<upper_sidelobe_suppression_horizon_to_20 value="18.4"/>
```

Relevance

- This parameter indicates the amount of interfering signal radiated above the horizon due to the upper sidelobes presence.
- It also indicates the minimum suppression level of the sidelobes above the main beam in a 20° sector above the horizon.

3.3.13 Maximum Upper Sidelobe Level

Parameter Definition

- The maximum upper sidelobe level is in the elevation cut the gain difference between the main beam peak and the highest level amidst all the sidelobes above the main beam peak and up to the zenith.

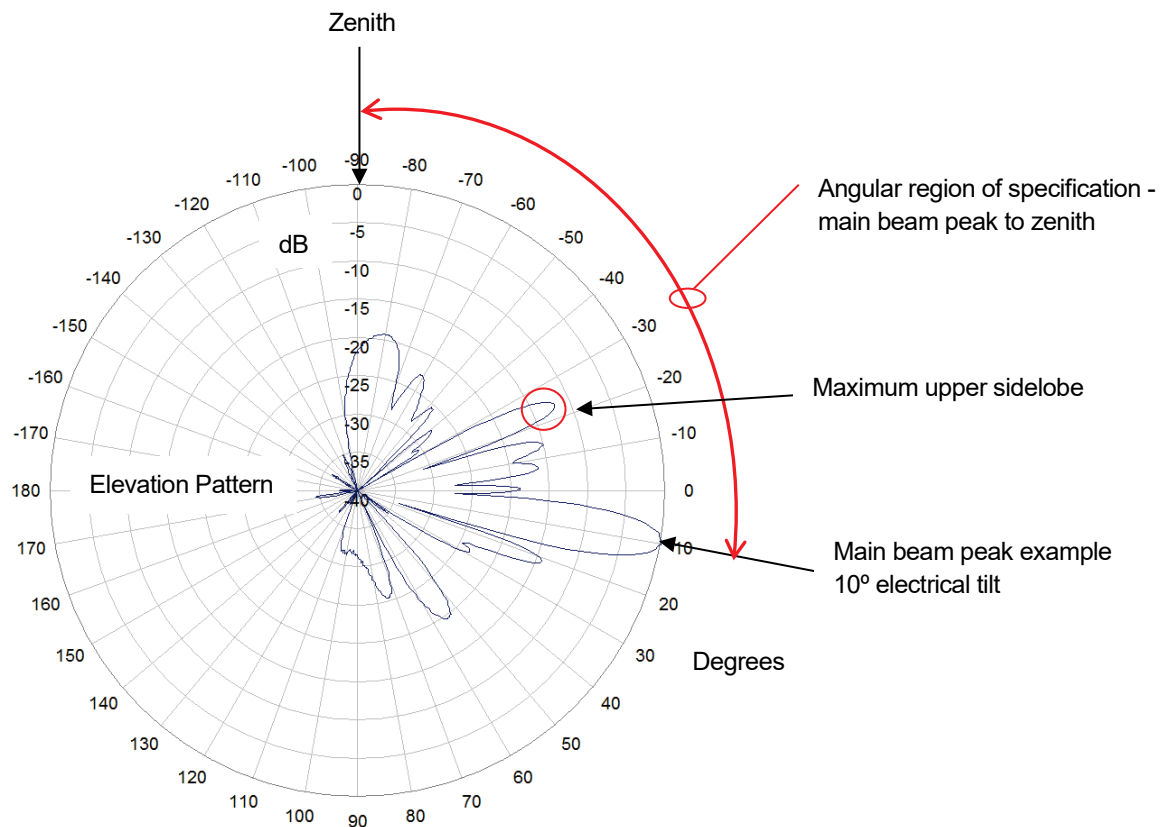

Figure 28—Maximum Upper Sidelobe Level.

Specification Definition

- Maximum upper sidelobe level is a maximum value in dB.
- The angular region of specification elongates from the main beam peak to the zenith.

- It is subject to a statistical validation for a single-sided parameter.
- This parameter is to be defined for the nominal sub-bands in a broadband antenna. It will be assumed that the specification is valid for the full electrical downtilt range, and for all the ports associated with each frequency sub-band of the antenna.
- For omnidirectional antennas, this parameter shall be referenced to the cut by the beam peak axis.

Specification Example

<i>Type: Statistical</i>	1710-1880 MHz	1850-1990 MHz	1920-2170 MHz
Maximum Upper Sidelobe Level	> 14.3	> 15.1	> 15.6

XML - Tag Example

<maximum_upper_sidelobe_level value="14.3"/>

Relevance

- Upper sidelobes are generally undesirable, considering that even if they do not create interference, they represent energy radiated in unwanted directions and therefore lost to the system. Consequently a low value of maximum upper sidelobe level is beneficial.

3.3.14 Azimuth Interference Ratio

Parameter Definition

- AIR is defined as the ratio of the integrated radiation intensity inside the antenna’s sector edges to its integrated interfering radiation. The sector is in this case referenced to the projection of the mechanical boresight onto the azimuth pattern.

Specification Definition

- It is subject to a statistical validation for a double-sided parameter.
- The AIR is defined as the combination of a typical (mean) value and a tolerance, both in dB.
- It is calculated from both the Co-pol pattern and the Cr-pol pattern in the form of:

$$AIR = 20 \log_{10} \left(\frac{Pd_c}{Pu_c + Pu_x} \right)$$

Where:

- *Pd_c* is defined as the radiation magnitude that is the root square sum of the total in-sector co-polar pattern levels.
- *Pu_c* is defined as the radiation magnitude that is the root square sum of the total out-of-sector co-polar pattern levels.
- *Pu_x* is defined as the radiation magnitude that is the root square sum of the total in- and out-of-sector cross-polar pattern levels.
- The root square sum of all the pattern levels shall be calculated by each angular unit (see Section 4.2 for the definition of angular unit).
- Those above are not strictly definitions of power but they are approximations used to calculate the power over an angular region, under the hypothesis that the angular step is one degree and that the angular step is the same for all the power factors.

- This parameter is to be defined for the nominal sub-bands in a broadband antenna. It will be assumed that the specification is valid for the full electrical downtilt range, and for all the ports associated with each frequency sub-band of the antenna.
- For multi-beam antennas type II, this parameter shall not be given.
- For omnidirectional antennas, this parameter shall not be given.

Specification Example

<i>Type: Statistical</i>	1710-1880 MHz	1850-1990 MHz	1920-2170 MHz
Azimuth Interference Ratio	11.0 ± 0.5	11.5 ± 0.6	11.8 ± 0.7

XML - Tag Example

```
<azimuth_interference_ratio value="11.0" tolerance="0.5"/>
```

Relevance

- It is a parameter that allows comparison of various antennas' rejection of interference to cells illuminated from the same site.

3.3.15 Azimuth Nominal Beam Directions

Parameter Definition

- For a multi-beam antenna with beams pointed in the azimuth plane, the nominal directions of all the main beams.

Note: This parameter is set as optional, in fact if the antenna is a single-beam or omnidirectional, it shall not be given. Vice versa, this parameter shall be treated as optional only for multi-beam type I antennas, and as required for multi-beam type II antennas.

Specification Definition

- The azimuth nominal beam directions are the nominal values in degrees of the beam directions with respect to the mechanical boresight.

Specification Example

<i>Type: Nominal</i>	Beam A (Cluster A) Ports 1 & 2	Beam B (Cluster B) Ports 3 & 4	Beam C (Cluster C) Ports 5 & 6
Azimuth Nominal Beam Directions	-30	0	+ 30

XML - Tag Example

```
<azimuth_nominal_beam_directions value="-30; 0; 30"/>
```

Relevance

- A specification defining the geometry of the site and sectors.
- One of the parameters contributing to the characteristics and extent of the cell sector coverage.

3.3.16 Azimuth Beam Pan Angles

Parameter Definition

- The azimuth beam pan angles are the nominal beam directions in the azimuth plane, which the antenna can point to, when its beam is electrically steered.

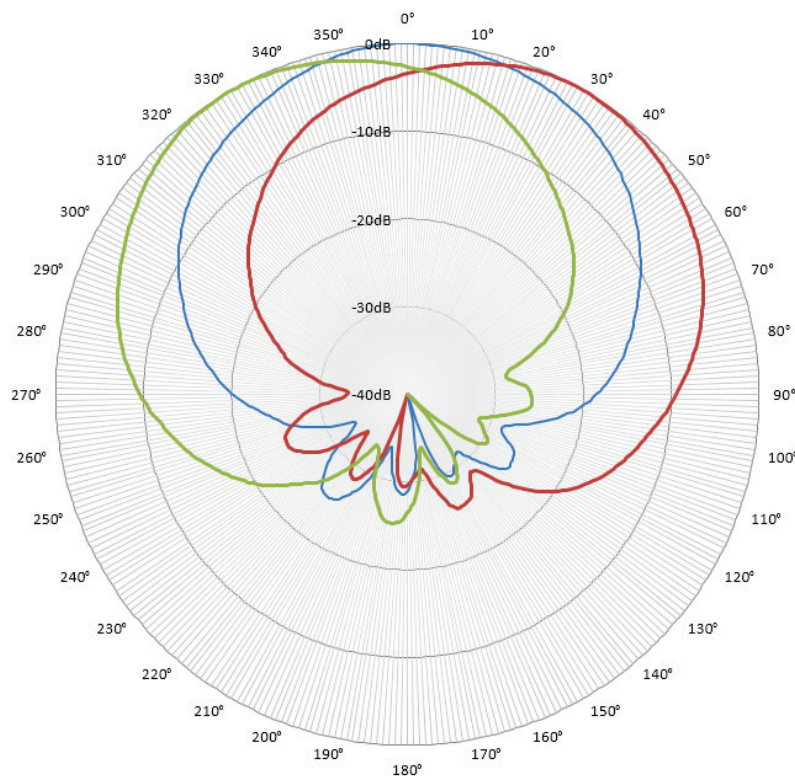

Figure 29—Some patterns of an azimuth beam steering antenna (pan angles: -30°; 0°; +30°).

Specification Definition

- It is a list of relevant pan angles with respect to the antenna mechanical boresight (pan = 0°).
- The values in the list are nominal ones in degrees.
- Negative values shall indicate counterclockwise beam panning, vice versa positive values shall indicate clockwise beam panning.
- Since electrical beam panning in the azimuth plane is conceptually similar to electrical tilting in the elevation plane, the recommendations on the relevant pan angles are the same as those specified for the electrical downtilt (see Section 4.2), except that the angular resolution shall in this case be at least 10 degrees. Pan = 0° shall be the reference for the all the other angles.
- Since different pan angles produce different antenna patterns, the antenna's parameters shall be described for each pan angle by a single XML file (see Section 10.1), which shall be named accordingly (see Section 10.1.1).

Specification Example

List of XML files of the same datasheet version of an antenna “XYZ” capable of steering between -30° and +30°:

```
BASTA10-0_CELLMAX_XYZ, PANM030_1999-12-30_V00_F.xml  
BASTA10-0_CELLMAX_XYZ, PANM020_1999-12-30_V00_F.xml  
BASTA10-0_CELLMAX_XYZ, PANM010_1999-12-30_V00_F.xml  
BASTA10-0_CELLMAX_XYZ, PANP000_1999-12-30_V00_F.xml  
BASTA10-0_CELLMAX_XYZ, PANP010_1999-12-30_V00_F.xml  
BASTA10-0_CELLMAX_XYZ, PANP020_1999-12-30_V00_F.xml  
BASTA10-0_CELLMAX_XYZ, PANP030_1999-12-30_V00_F.xml
```

XML - Tag Example

- Not applicable

Relevance

- This is one of the parameters contributing to the characteristics and extent of the cell sector coverage.
- It is a parameter that can be adjusted for:
 - Sector alignment and hand-off optimization.
 - RF coverage and interference optimization.
 - Sector load balancing.

3.3.17 Azimuth Beamwidth Fan

Parameter Definition

- For an electrically variable azimuth beamwidth antenna, the azimuth beamwidth fan is the list of nominal azimuth half-power beamwidths that the antenna can be set to exhibit by electrically altering its beam.

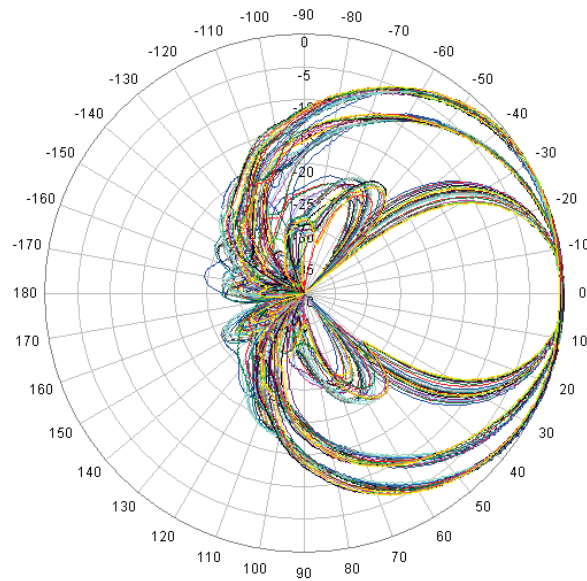

Figure 30— Patterns of a variable azimuth beamwidth BSA (35°/65°/105° pattern overlays).

Specification Definition

- For the purpose of this whitepaper, a fan angle is defined as the nominal H_HP BW (see Section 2.8) of one of the possible azimuth patterns of an electrically variable azimuth beamwidth antenna.
- It is a list of relevant fan angles.
- The values in the list are nominal ones in degrees.
- Since different fan angles produce different antenna patterns, the antenna’s parameters shall be described for each fan angle by a single XML file (see Section 10.1), which shall be named accordingly (see Section 10.1.1).
- The parameters of antennas that are not able to vary their beam continuously shall be described by a single XML file for each fan angle possibility.
- The parameters of antennas that are able to vary their beam continuously shall be described by a single XML file for each relevant fan angle. The recommendations on the relevant fan angles are similar to those specified for the electrical downtilt (see Section 4.2), except that the angular resolution shall in this case be at least 10 degrees. The lowest fan angle shall be the reference for the all the other ones.

Specification Example

List of XML files of the same datasheet version of an antenna “XYZ” capable of varying its H_HP BW only to 35°, 65° and 105°:

```
BASTA10-0 AMPHENOL XYZ, FAN035_2007-05-01_V02_P.xml
BASTA10-0 AMPHENOL XYZ, FAN065_2007-05-01_V02_P.xml
BASTA10-0 AMPHENOL XYZ, FAN105_2007-05-01_V02_P.xml
```

List of XML files of the same datasheet version of an antenna “XYZ” capable of varying its H_HP BW continuously between 65° and 90°:

```
BASTA10-0 AMPHENOL XYZ, FAN065_2007-05-01_V02_P.xml
BASTA10-0 AMPHENOL XYZ, FAN070_2007-05-01_V02_P.xml
```

BASTA10-0 AMPHENOL XYZ, FAN080_2007-05-01_V02_P.xml
 BASTA10-0 AMPHENOL XYZ, FAN090_2007-05-01_V02_P.xml

XML - Tag Example

- Not applicable

Relevance

- This is one of the parameters contributing to the characteristics and extent of the cell sector coverage.
- It is a parameter that can be adjusted for:
 - Sector alignment and hand-off optimization.
 - RF coverage and interference optimization.
 - Sector load balancing.

3.3.18 Maximum Effective Power of Cluster

Parameter Definition

- The maximum power, which can be transmitted into one antenna cluster, and which shall be withstood by the antenna without it suffering permanent damage or being mechanically or electrically affected (hence subject to parameters' alteration).

Specification Definition

- Power is defined as effective CW power.
- This is an absolute, maximum parameter specified in Watts.
- It is specified at sea level over the environmental conditions specified for the antenna.
- Specification shall reference the full frequency range, full electrical downtilt range, and the associated ports of the cluster.

Specification Example

<i>Type: Absolute</i>	1710-2170 MHz
Maximum Effective Power of Cluster	500

XML - Tag Example

<maximum_effective_power_cluster value="500"/>

Relevance

- Exceeding the specified power rating can damage the antenna.

4 Validation and Specification of RF Parameters

4.1 Industry Practice for Base Station Antennas

In a commercial RFQ process cellular operators specify the expected performance of the antennas that need to be purchased for deployment in their networks. Detailed specifications are provided to antenna vendors, who respond with specification datasheets or other documentation that compares how the performance of their products complies with the RFQ requirements. In order to accurately compare the properties of one antenna vendor's product with another's, all parties in the supply chain shall have a common understanding of the antenna parameters definitions, and just as critically, of the methodology used to calculate and validate the associated specifications. This section of the whitepaper addresses the calculation and validation of the RF specifications.

4.2 General Guidance

- For the validation and the specification of radiation pattern derived parameters, the NGMN guidelines require a specific set of sub-bands and associated frequencies to be measured and analyzed. See Section 9.1 for details.
- Parameters are classified as **absolute** or **statistical**. Statistical parameters are further classified as **single-sided parameters** or **double-sided parameters**.
- In general, **absolute parameters** are defined for the full frequency range of an antenna, and are based on swept frequency measurements of the input ports. For these parameters, unless otherwise noted, it will be assumed that the specification is valid for the full frequency range, full electrical downtilt range, and all the associated ports of the antenna. E.g.: 1710-2170 MHz; 0°-10°; +45 and -45 ports.
- In general, **statistical parameters** are defined in sub-bands of the full frequency range of an antenna, and are based on radiation pattern measurements. For these parameters, unless otherwise noted, it will be assumed that the specification is valid for the full sub-band frequency range, full electrical downtilt range, and all associated ports of the antenna. E.g.: 1710-1880 MHz; 0°-10°; +45 and -45 ports.
- **Typical parameters** are statistical parameters that are defined by a mean value and a tolerance. If the specification's measured values constituted a normal (Gaussian) probability distribution, the tolerance would be defined as ± 1.5 standard deviations. The reason why these parameters are also called **double-sided** lies in the fact that typical parameters are validated by a set of measured data points revolving around the mean value, both to its "left side" (- tolerance) and to the "right side" (+ tolerance) in the distribution function.
 - Gain is a special case of a typical parameter. It is specified for each of the sub-bands included in the frequency range of the antenna, for the associated ports and for the specific lowest, middle, and highest tilt values over the electrical tilt range of the antenna. In addition, an "over all tilts" (all the electrical tilt angles are included in the calculation) gain is specified as a standard typical parameter.
- **Maximum** or **minimum parameters** are statistical parameters that are defined by a threshold value. If the specification's measured values constituted a normal (Gaussian) probability distribution, the maximum threshold value would be determined by their mean value plus one standard deviation, while the minimum threshold value would be determined by their mean value minus one standard deviation. The reason why these parameters are called **single-sided** lies in the fact that these parameters are validated by a set of measured data points, respectively only to the "left side" (for

“maximum” parameters) or only to the “right side” (for “minimum” parameters) of a threshold in the distribution function.

- Elevation downtilt deviation is a special case of a maximum parameter. The absolute maximum differences between the real tilt values (calculated as specified in Section 3.2.6) and the nominal tilt degree shall be calculated, and with those the parameter shall be specified for each of the sub-bands included in the frequency range of the antenna, for the associated ports and for the whole tilt range.
- For the single-sided parameters that use decibels as measurement unit there shall be no more than 3 dB excursion beyond the specified value. For example, if the threshold for the first upper sidelobe suppression was specified as 15.2 dB, there should be no value lower than 12.2 dB in the whole set of measured values. If that were to happen, the parameter should be labeled as “not applicable”.
- Some parameters require the measurement of Co-Pol as well as Cr-Pol patterns, both of which require a scrupulous alignment of the whole measurement system (see Figure 56). A misalignment can lead to sub-optimal figures, due to the decrease of Co-Pol amplitudes and increase of the Cr-Pol ones.
- Pattern data shall be extracted at a minimum of 1° angular resolution if the pattern has an average HPBW equal to 20° or broader. Vice versa if the pattern has an average HPBW of less than 20°, it can happen that the patterns exhibit some “spikes”: under these circumstances, these sudden changes of pattern level shall be handled by extracting pattern data with 0.5° angular resolution. This rule applies only for the sake of parameters’ precision and shall not affect any other information that the vendors provide to the operators (radio planning files, etc.).
- Pattern data for antennas capable of electrical downtilt shall be taken with the same step at least every 1° over the entire specified tilt range. Antennas whose tilt-range starts and/or stops with half a degree follow the same principle, except that if the chosen step is 1°, the first and/or last tilt shall be measured with a step of 0.5° (e.g.: 2.5° to 10° downtilting antenna’s pattern data will be taken at: 2.5°; 3°; ...; 10°. 2.5° to 10.5° downtilting antenna’s pattern data will be taken at: 2.5°; 3°; ...; 10°; 10.5°).
- Pattern data shall be given for the elevation and azimuth pattern cuts.
- Legacy vendor specification datasheets and legacy NGMN datasheets shall not be required to be updated as a whole. It is foreseen that operators might request NGMN compliance for new RFQs and new products, therefore the recommendations present in this document shall be only applied to antennas that are developed after the date of its publication. Legacy NGMN datasheet shall therefore keep their validity for legacy products.

4.3 Absolute RF Parameters

For absolute parameters, 100% of the measured data falls below a maximum value or above a minimum value and statistical analysis is not necessary. In those cases there shall be no data points excursions beyond the specified value.

Typically these parameters are specified for the full frequency range, full electrical downtilt range, and associated ports of the antenna (for example: 1710-2170 MHz; 0°-10°; +45 and -45 ports).

4.4 Statistical RF Parameters

Considering that antennas’ patterns change with frequency, tilt and polarization, for certain parameters it is not suitable to use absolute maxima or minima as metrics to evaluate an antenna’s performance. In fact,

by using them, a misrepresentation of the antenna could be likely. A very limited set of values (worst case: a single one) amongst the entire dataset of measured ones would characterize a parameter, even though all the other values are sensibly higher or lower. In these cases a statistical analysis excluding worst and best values is necessary to give a better overview of the aforementioned performances.

4.4.1 General methodology

For a given antenna model, its radiation patterns are measured at the recommended frequencies (see Section 9.1) for each of the required sub-bands in the full antenna bandwidth.

A full antenna bandwidth (or main frequency range) that is used only as an example in this section of the whitepaper is: 1710-2170 MHz. The specified sub-bands that are used only as an example in this section of the whitepaper are the following three:

Band	1710-2170 MHz		
Sub-Bands	1710-1880 MHz	1850-1990 MHz	1920-2170 MHz

Recommendation on sub-bands can be found in Section 9.1.

For antennas with variable electrical downtilt, each individual pattern is measured (as specified in Section 4.2), analyzed, and finally a value is calculated according the definition of the chosen parameter. The resulting dataset of values is then statistically analyzed, so that a single value that represents the specification of that very parameter can be obtained.

In the table below it is shown an example of a full dataset of the azimuth beamwidth parameter for the sub-band 1710-1880 MHz:

Az -3 dB beamwidth									
1710 - 1880 MHz	1.71	1.73	1.75	1.76	1.79	1.81	1.84	1.85	1.88
L-PORT DEG:0	68.84	69.01	68.94	68.80	67.98	67.06	66.98	66.37	65.75
R-PORT DEG:0	69.86	70.02	69.75	69.34	66.91	67.28	66.52	65.71	66.15
L-PORT DEG:2	69.79	68.90	68.47	68.35	67.60	67.21	66.82	66.54	65.62
R-PORT DEG:2	70.51	69.21	68.59	68.45	67.83	68.08	66.30	65.69	65.51
L-PORT DEG:4	69.50	69.12	68.91	68.82	68.37	67.74	66.38	66.74	66.02
R-PORT DEG:4	69.16	69.05	68.91	68.62	67.32	67.91	66.19	66.36	65.52
L-PORT DEG:6	69.17	68.79	68.63	68.59	68.31	67.31	66.81	66.54	65.85
R-PORT DEG:6	69.42	69.02	68.65	68.56	68.18	68.27	67.62	67.03	65.92
L-PORT DEG:8	69.64	69.55	69.33	69.12	67.67	67.16	66.52	66.56	66.65
R-PORT DEG:8	70.23	69.27	68.71	68.37	67.37	68.00	67.56	67.09	66.35
L-PORT DEG:10	69.80	69.23	68.93	68.76	67.87	68.08	67.12	66.49	66.12
R-PORT DEG:10	70.03	68.93	68.55	68.37	67.44	67.91	67.50	67.21	66.29
L-PORT DEG:1	69.54	68.94	68.58	68.44	67.60	67.13	66.90	66.50	65.58
L-PORT DEG:3	69.86	69.02	68.69	68.58	68.04	67.60	66.56	66.75	65.89
L-PORT DEG:7	69.39	69.18	68.99	68.85	68.04	67.02	66.63	66.47	66.23
L-PORT DEG:9	69.77	69.57	69.39	69.15	67.64	67.40	66.67	66.49	66.61
L-PORT DEG:5	69.26	68.92	68.74	68.68	68.35	67.61	66.62	66.67	66.00
R-PORT DEG:1	70.44	69.39	68.90	68.68	67.60	67.87	66.38	65.59	65.69
R-PORT DEG:3	69.79	69.07	68.69	68.51	67.54	68.04	66.02	65.98	65.41
R-PORT DEG:5	69.27	69.01	68.77	68.59	67.81	68.13	66.88	66.78	65.71
R-PORT DEG:7	69.96	69.17	68.68	68.52	67.89	68.23	67.77	67.07	66.22
R-PORT DEG:9	70.11	69.24	68.57	68.35	67.27	67.88	67.56	67.18	66.41
	Min	Max	Mean	Stdv					
Overall	65.41	70.51	67.90	1.26					

Table 1—Parameter dataset – single sub-band, all tilts, all ports.

4.4.2 Double-Sided Specifications

For some parameters, their relevance is best captured by how the whole calculated dataset revolves around a typical value; therefore, these are designated as double-sided parameters (see also Section 4.2). Their statistical validation is applied in the measurement units identified within their specification definition.

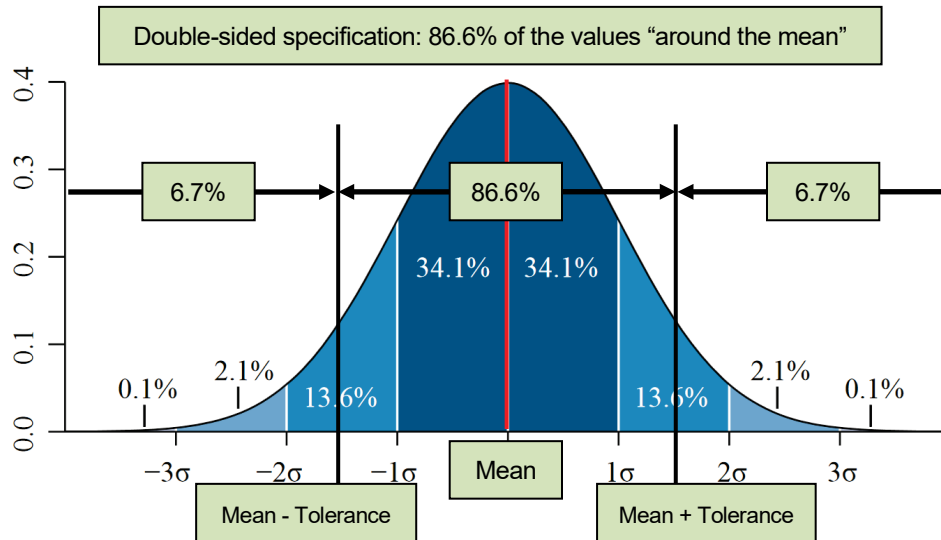

Figure 31—Double-sided specification for a normal distribution.

Even though the definition of double-sided parameters is inspired by Gaussian statistic, in reality most of the parameters' probability distribution are questionably a Gaussian curve. Even if the definition of mean (μ) is obviously the same (it is **the average of the values in the distribution as linear numbers**), the tolerance definitions do not coincide: for a normal distribution would simply be equal to $\pm 1.5 \cdot$ standard deviation (σ); for a real one instead, it is defined as **the average of the distances from the mean of the two values, both of which exclude from the distribution the 6.7% of the measured values, that is respectively its far left side (from 0% to 6.7%) and its far right side (from 93.3% to 100%)**.

A normal distribution is also a continuous curve, but in the real world it is possible only to approximate a probability distribution function using a sorted array of measured values (one value for each frequency, polarization and tilt degree). Thus it is possible that the threshold values "mean - tolerance" (6.7th percentile) and "mean + tolerance" (93.3rd percentile) are not values that were actually measured. Below it is shown a block chart describing the algorithm to correctly find those:

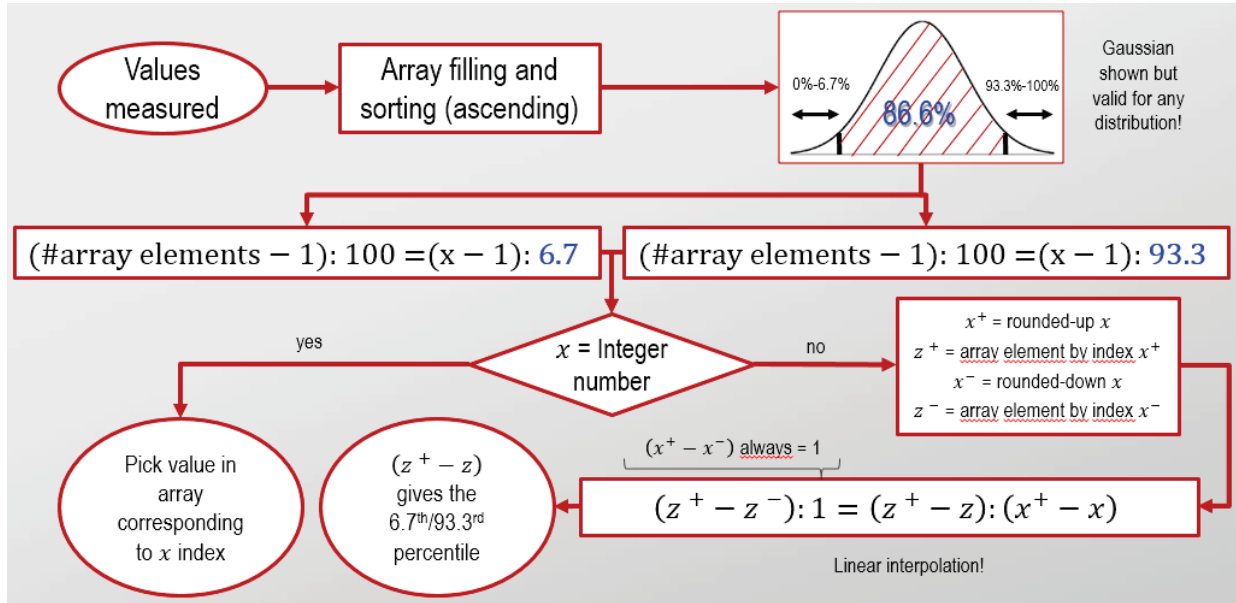

Figure 32—Algorithm to find "mean - tolerance" and "mean + tolerance"

Once the two percentiles are found, the modulus of their differences from the mean value shall be averaged in order to obtain a single number hence designated as tolerance.

4.4.3 Double-Sided Specification Example—Azimuth HPBW Validation

For this example of validation process, the calculation of the azimuth HPBW specification in the 1710-1880 MHz sub-band will be used.

First of all, the antennas radiation patterns for the sub-band are analyzed according to the parameter definition (see Section 3.2.4):

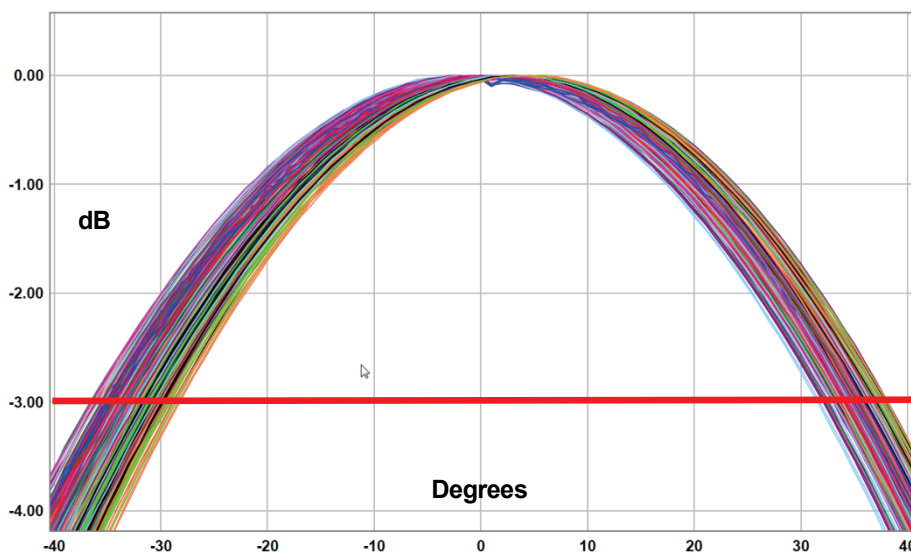

Figure 33—Azimuth beam-peak patterns plots - 1710-1880 MHz, all ports, and all tilts.



The values for azimuth beamwidth are calculated for each frequency in the sub-band, each port, and each downtilt setting:

EI. Tilt	2.5	2.5	3.0	3.0	4.0	4.0	5.0	5.0	6.0	6.0	7.0	7.0	8.0	8.0
Polarization	+45°	-45°	+45°	-45°	+45°	-45°	+45°	-45°	+45°	-45°	+45°	-45°	+45°	-45°
1710 MHz	68.2	69.4	66.9	68.7	68.0	68.7	68.7	68.9	69.8	68.8	69.6	68.6	70.8	68.8
1733 MHz	66.0	69.0	65.9	69.0	65.0	68.3	65.1	67.9	66.2	68.4	67.0	69.0	69.4	69.5
1748 MHz	64.3	68.6	65.6	69.4	64.2	69.0	63.5	68.3	63.5	68.1	65.3	68.3	68.6	68.9
1755 MHz	64.0	68.6	64.0	69.9	63.0	69.9	62.5	69.5	62.9	68.8	64.2	68.5	67.8	68.8
1785 MHz	64.9	64.4	63.5	64.2	62.8	64.7	62.1	64.8	60.9	64.5	60.7	64.1	60.7	63.6
1805 MHz	62.1	61.9	61.1	62.6	60.4	62.7	60.0	62.8	59.3	62.6	59.0	62.4	58.8	62.1
1843 MHz	66.2	62.9	65.0	63.0	64.1	62.2	63.6	61.8	62.9	61.9	63.2	62.6	63.4	63.5
1850 MHz	66.4	62.6	65.1	62.9	64.1	62.4	63.6	62.3	63.4	62.7	63.7	63.4	64.1	64.1
1880 MHz	66.0	65.5	64.9	64.3	64.5	64.1	64.2	64.0	64.2	64.4	64.6	65.2	65.5	66.6

Table 2—Complete dataset of azimuth HPBWs.

The set of measured values is finally statistically analyzed to determine the specification:

- The array containing all the values above counts 126 elements (9 frequencies x 7 tilts x 2 polarizations).
- The minimum value is 58.8° and the maximum is 70.8°. The mean is the sum of all the elements (degrees do not need the conversion in linear numbers), divided by 126.
- The proportion $(126 - 1) : 100 = (x - 1) : 6.7$ solved by x, returns $x = 9.4$. Where x is the array index of the 6.7th percentile.
- The proportion $(126 - 1) : 100 = (x - 1) : 93.3$ solved by x, returns $x = 117.6$. Where x is the array index of the 93.3rd percentile.
- Once the array is sorted in ascending fashion, it can be seen that the 9th element (index = 9) is 61.1°, the 10th is 61.8, the 117th and 118th are both 69.4°.
- Clearly, the “mean + tolerance” value is 69.4°, while for the “mean – tolerance” a linear interpolation between 61.1° and 61.8° is necessary.
- Using the following equivalences: $z^+ = 61.8^\circ$; $z^- = 61.1^\circ$; $x^+ = 10$; $x^- = 9$; the value of “mean - tolerance” can be obtained: $(z^+ - z^-) = 61.4^\circ$.
- The modulus of the differences of the two values from the mean is respectively: 3.7° and 4.3°, therefore the tolerance is their average, which is 4.0°.

Azimuth beamwidth	# Array elements	Min	Max	Mean	Tolerance
1710-1880 MHz	126	58.8°	70.8°	65.1°	4.0°

Table 3—Summary of azimuth HPBW statistics.

The specification is set as:

Type: Statistical	1710-1880 MHz
Azimuth HPBW	65.1 ± 4.0

As previously stated, in this example, the azimuth HPBW has only been calculated for one sub-band (1710-1880 MHz).

This procedure has to be repeated two additional times to populate the full specification table for the parameter:

Type: Statistical	1710-1880 MHz	1850-1990 MHz	1920-2170 MHz
Azimuth HPBW	65.1 ± 4.0	64.8 ± 1.6	63.4 ± 2.3

For the purpose of this whitepaper, it is instructive to show the plotted the azimuth HPBW values as a function of frequency, and the distribution of the calculated values in a histogram. These plots are shown below:

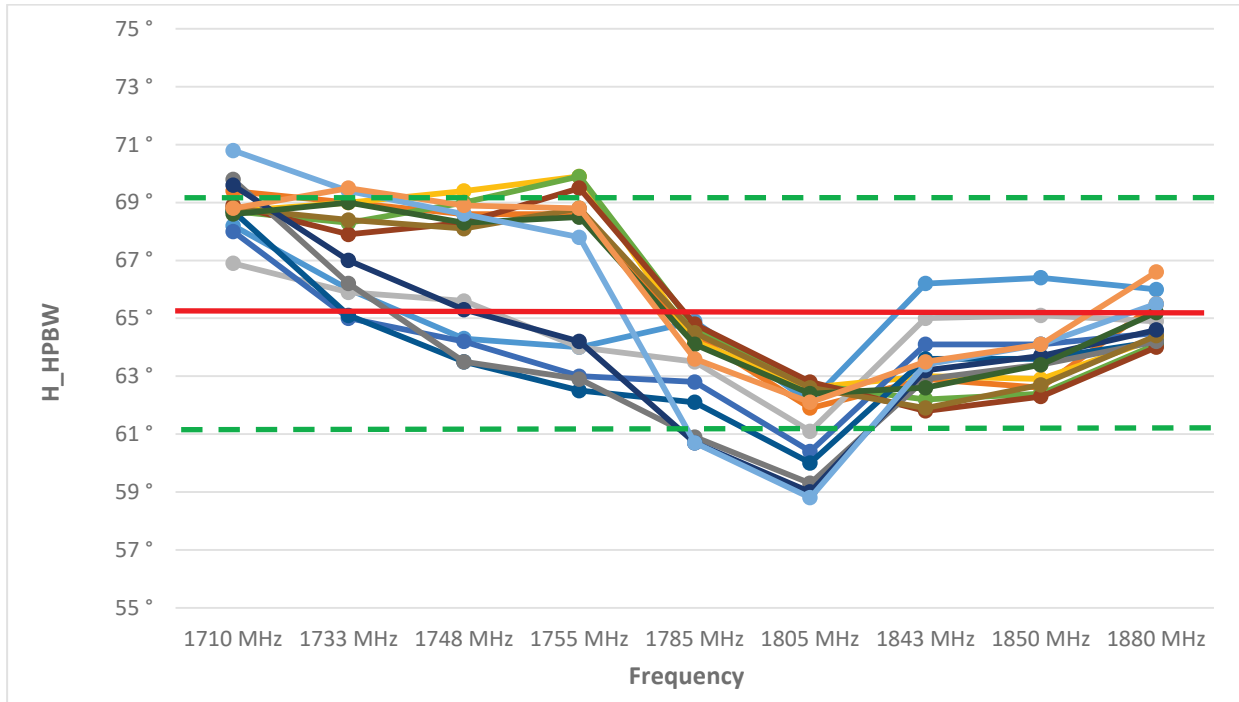

Figure 34—Azimuth HPBW for each tilt and port as a function of the frequency.

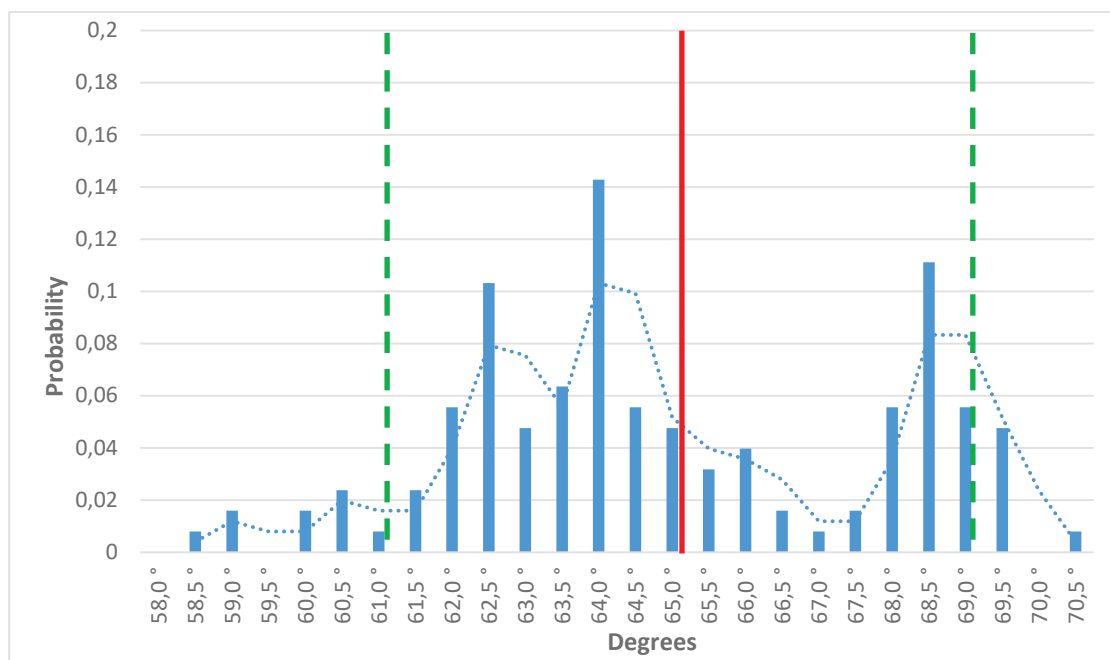

Figure 35—Histogram of azimuth HPBW values.

The histogram above shows well that the distribution of the values is not Gaussian. In fact if the tolerance would have been incorrectly calculated as $1.5 * \sigma$, it would have been equal to 4.3° .

4.4.4 Single-sided Specifications

For some parameters, their relevance is best captured by how the dataset of calculated values fall above or below a threshold value; therefore, they are designated as single-sided parameters (see also Section 4.2). The statistical validation is applied in the units identified within the specification definition.

A “maximum” specification for a parameter is defined when the above mentioned dataset is mostly “below” a specified value: this does not strictly mean that the values must be lower than it, since the physical meaning of the parameter and its associated sign play an important role in the meaning of “below”. For Gaussian statistics, the “maximum” would be a threshold value defined by the mean plus the standard deviation, both calculated on the dataset used to validate the specification. Since $\mu + \sigma$ serves as limit for the lower 84% of the values in a normal probability distribution, and since in reality the parameters’ distributions are hardly Gaussian, a “maximum” will be generally defined as the value that demarcate the lower 84% of the entire dataset. In other words, 84% of the measured values will fall below the given specification (threshold).

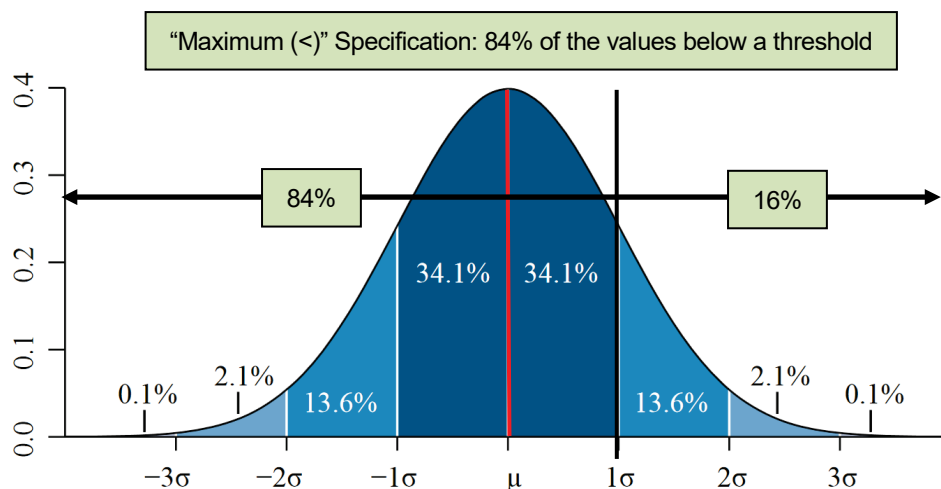

Figure 36—Single-sided specification (maximum).

A “minimum” specification for a parameter is defined when the above mentioned dataset is mostly “above” a specified value: this does not strictly mean that the values must be higher than it, since the physical meaning of the parameter and its associated sign play an important role in the meaning of “above”. For Gaussian statistics, the “minimum” would be a threshold value defined by the mean minus the standard deviation, both calculated on the dataset used to validate the specification. Since $\mu - \sigma$ serves as limit for the higher 84% of the values in a normal probability distribution, and since in reality the parameters’ distributions are hardly Gaussian, a “minimum” will be generally defined as the value that demarcate the higher 84% of the entire dataset. In other words, 84% of the measured values will fall above the given specification (threshold).

“Minimum (>)” Specification: 84% of the values above a threshold

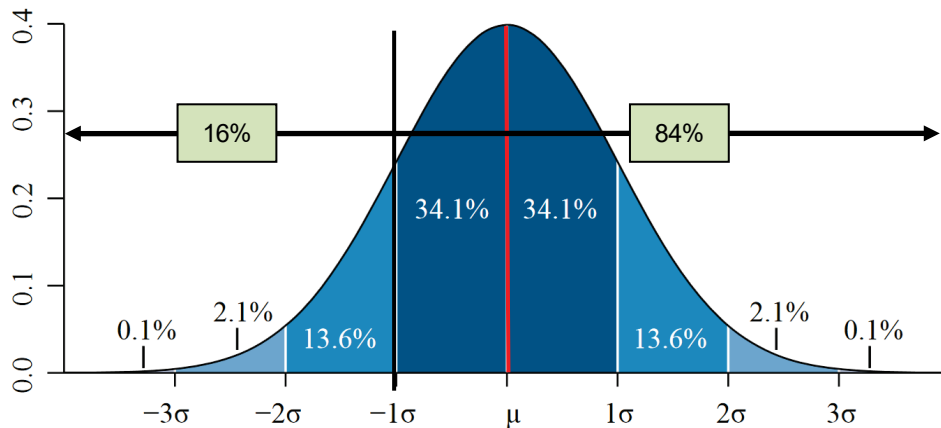

Figure 37—Single-sided specification (minimum).

A normal distribution is also a continuous curve, but in the real world it is possible only to approximate a probability distribution function using a sorted array of measured values (one value for each frequency, polarization and tilt degree). Thus it is possible that the threshold values “maximum” (84th percentile) and “minimum” (16th percentile) are not values that were actually measured. Below it is shown a block chart describing the algorithm to correctly find those:

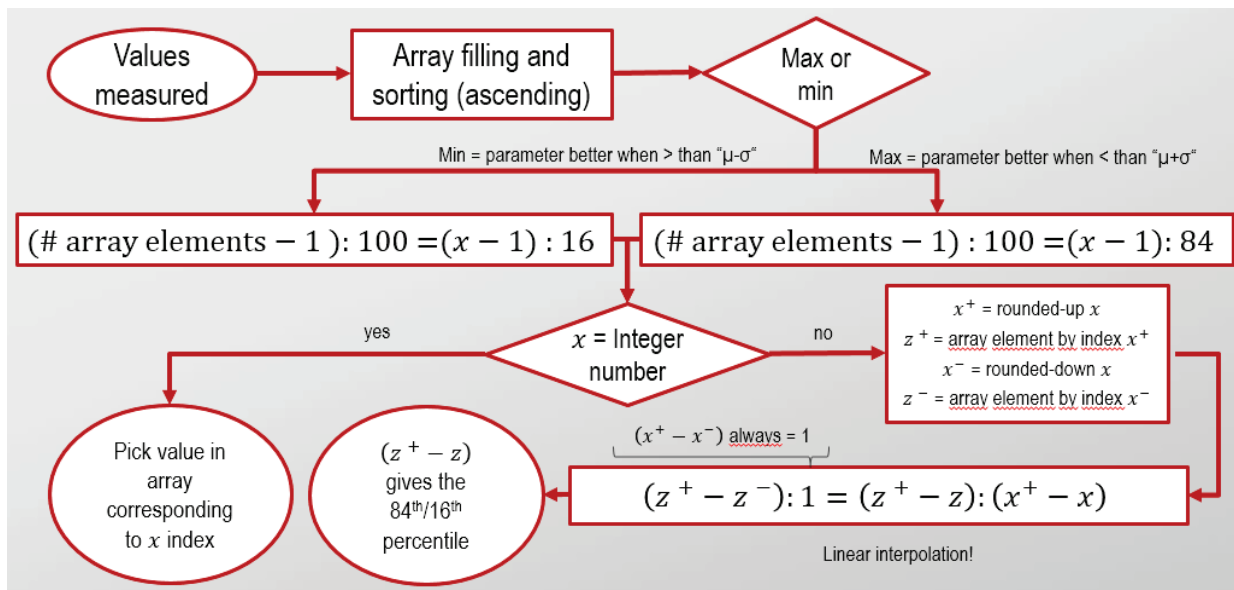

Figure 38—Algorithm to find "maximum" and "minimum".

4.4.5 Single-sided Specification Example – Azimuth Beam Port-to-Port Tracking Validation

For this example of validation process, the calculation of the azimuth beam port-to-port tracking specification in the 1710-1880 MHz sub-band will be used.

First, the antennas' radiation patterns for the sub-band are analyzed according to the parameter definition (see Section 3.3.9):

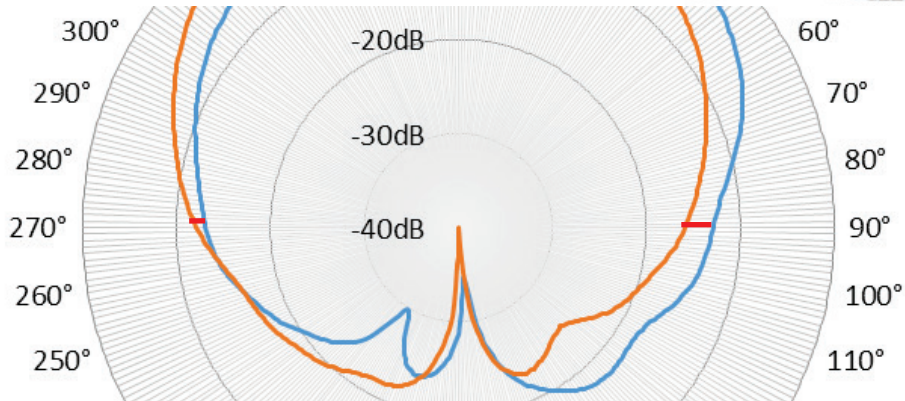

Figure 39—Polarizations pattern level difference of a 90° sector antenna for one frequency and a single downtilt degree.

EI. Tilt	2.0		3.0		4.0		5.0		6.0		7.0		8.0		9.0		10.0	
Sector	-90°	+90°	-90°	+90°	-90°	+90°	-90°	+90°	-90°	+90°	-90°	+90°	-90°	+90°	-90°	+90°	-90°	+90°
1710 MHz	0.0	0.5	0.3	0.1	0.2	0.1	0.1	0.1	0.2	0.1	0.2	0.1	0.2	0.1	0.3	0.1	0.5	0.1
1733 MHz	0.3	0.5	0.1	0.1	0.1	0.1	0.1	0.2	0.2	0.2	0.3	0.1	0.1	0.0	0.1	0.1	0.4	0.3
1748 MHz	0.4	0.9	0.2	0.4	0.2	0.3	0.2	0.3	0.5	0.3	0.7	0.1	0.5	0.1	0.3	0.1	0.4	0.4
1755 MHz	0.5	1.2	0.4	0.7	0.4	0.6	0.5	0.5	0.8	0.4	1.0	0.1	0.9	0.0	0.8	0.2	0.8	0.5
1785 MHz	0.5	2.1	0.6	2.3	0.5	2.4	0.4	2.2	0.6	2.3	0.7	2.3	0.7	2.3	0.6	2.3	0.6	2.5
1805 MHz	0.4	0.7	0.0	1.0	0.1	1.2	0.2	1.0	0.1	0.7	0.0	0.6	0.1	0.6	0.2	0.8	0.5	1.0
1843 MHz	2.3	2.6	2.4	2.9	2.4	3.0	2.4	2.9	2.4	2.8	2.3	2.8	2.2	2.8	2.1	2.6	2.0	2.2
1850 MHz	2.5	3.0	2.6	3.4	2.8	3.6	2.9	3.5	3.0	3.3	2.9	3.4	2.8	3.4	2.7	3.3	2.6	3.0
1880 MHz	1.9	2.7	1.9	2.5	2.1	2.5	2.2	2.5	2.3	2.6	2.7	2.7	2.9	3.0	2.9	3.3	2.9	3.3

Table 4—Complete dataset azimuth beam port-to-port tracking.

The set of measured values is finally statistically analyzed to determine the specification:

- The array containing all the values in the table above counts 162 elements (9 frequencies x 9 tilts x 2 directions).
- The minimum value is 0 dB and the maximum is 3.6 dB. The mean is the sum of all the elements (as linear numbers) divided by 162.
- In the table above the higher the number, the worse the signal difference, the worse the antenna's performance. To define the parameter 16% of the worst cases (higher values) are ruled out.
- The proportion $(162 - 1) : 100 = (x - 1) : 84$ solved by x, returns $x = 136.24$. Where x is the array index of the 84th percentile.
- Since 136.24 is not an integer number, an interpolation is necessary.
- Once the array is sorted in ascending fashion, it can be seen that the value lies between the 136th element (index = 136), which is 2.7 dB, and the 137th element (index = 137) of the array, which is 2.8 dB.
- The interpolation formula becomes: $0.1 : 1 = (2.8 - z) : (137-136.24)$ and ultimately gives a result of 2.7 dB.

Azimuth Beam Port-to-Port Tracking	# Array elements	Min = Best	Max = Worst	84%
1710-1880 MHz	162	0 dB	3.6 dB	2.7 dB

Table 5—Summary of azimuth beam port-to-port tracking statistics.

The specification is set as:

<i>Type: Statistical</i>	1710-1880 MHz
Azimuth Beam Port-to-Port Tracking	< 2.7

Note that the specification values are never more than 3 dB higher than the maximum found through the algorithm.

As previously state, in this example, azimuth beam port-to-port tracking has only been calculated for one sub-band (1710-1880 MHz).

This procedure has to be repeated two additional times to populate the full specification table for the azimuth beam port-to-port tracking parameter:

<i>Type: Statistical</i>	1710-1880 MHz	1850-1990 MHz	1920-2170 MHz
Azimuth Beam Port-to-Port Tracking	< 2.7	< 1.8	< 2.2

For the purpose of this whitepaper, it is instructive to show the plotted azimuth beam port-to-port tracking values as a function of frequency, and the distribution of the calculated values in a histogram. These plots are shown below:

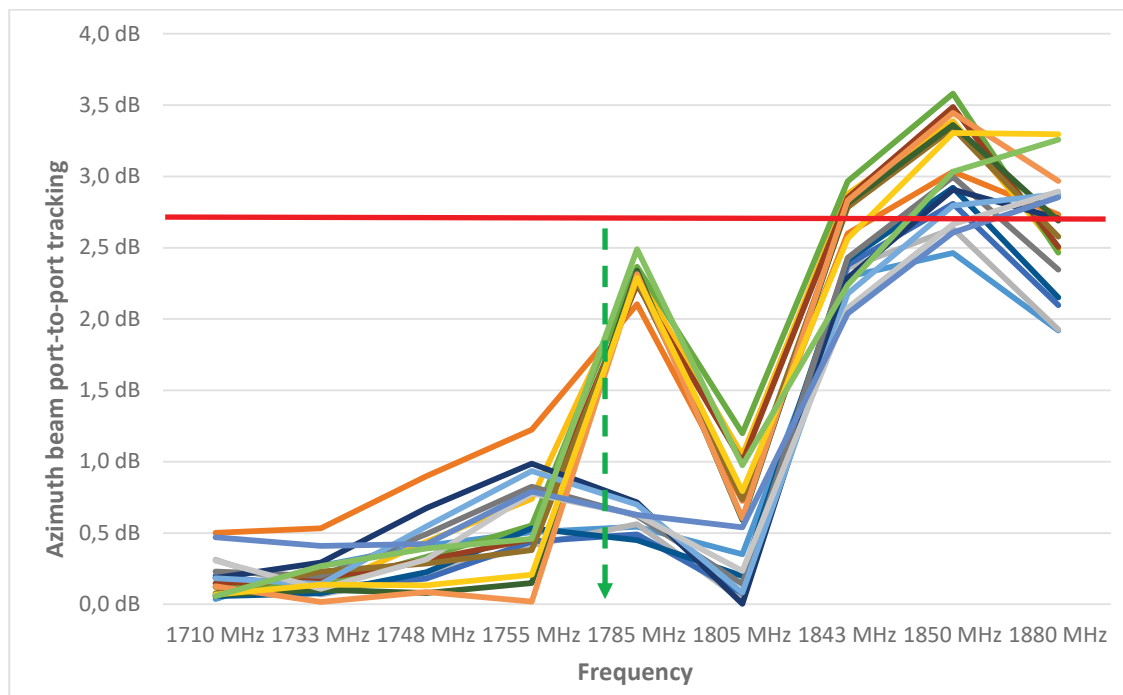

Figure 40—Azimuth beam port-to-port tracking for each tilt and port as a function of the frequency.

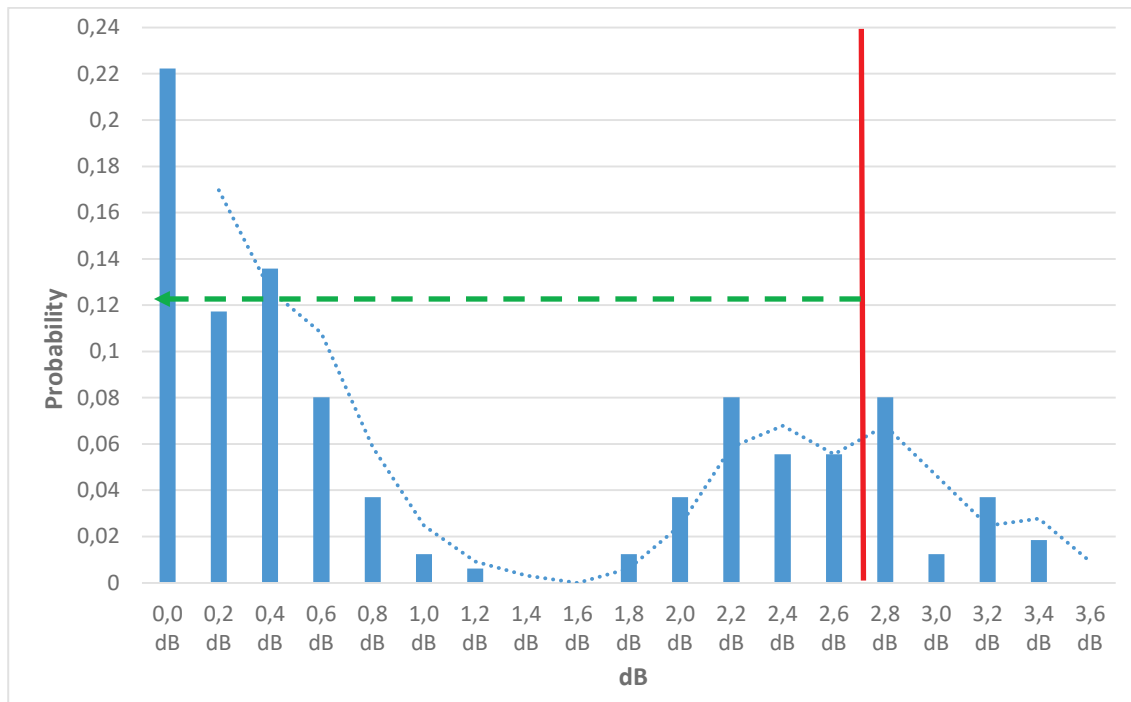

Figure 41—Histogram azimuth beam port-to-port tracking.

The histogram above shows well that the distribution of the values is not Gaussian. In fact if the parameter would have been incorrectly calculated as $\mu + \sigma$, it would have been equal to 2.5 dB.

4.4.6 Single-sided Specification Example – Upper Sidelobe Suppression, Peak to 20° Validation

For this example of validation process, the calculation of the upper sidelobe suppression, peak to 20° specification in the 1710-1880 MHz sub-band will be used.

First, the antennas' radiation patterns for the sub-band are analyzed according to the parameter definition (see Section 3.2.15):

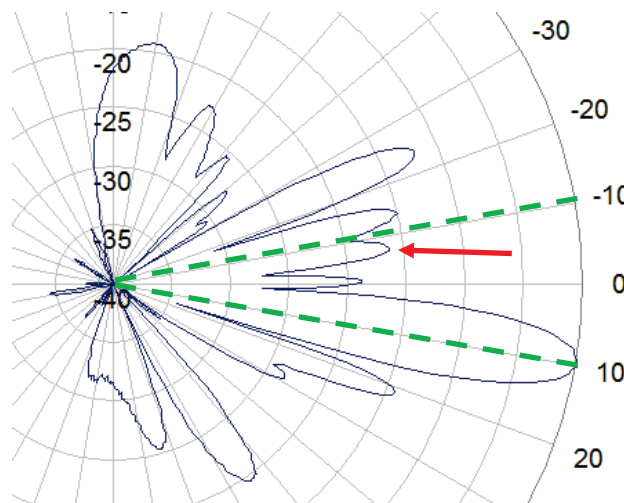

Figure 42—Worst sidelobe peak 20° above the main beam peak for one frequency, a single port and a single downtilt degree.

El. Tilt	2.5	2.5	3.0	3.0	4.0	4.0	5.0	5.0	6.0	6.0	7.0	7.0	8.0	8.0
Polarization	+45°	-45°	+45°	-45°	+45°	-45°	+45°	-45°	+45°	-45°	+45°	-45°	+45°	-45°
1710 MHz	17.1	17.9	16.8	17.5	15.4	15.4	15.5	15.0	17.1	16.3	18.1	16.7	17.7	15.3
1733 MHz	16.0	16.7	15.6	16.4	15.2	16.0	15.4	15.5	15.7	15.2	16.6	16.2	17.0	16.2
1748 MHz	17.1	17.0	16.7	16.3	15.8	15.1	15.9	15.0	16.8	15.9	16.5	17.0	16.3	17.1
1755 MHz	18.5	17.8	17.7	16.6	16.5	15.1	16.5	14.9	17.3	15.5	17.3	16.7	16.4	17.4
1785 MHz	19.0	17.6	18.4	17.4	17.8	16.6	17.4	16.0	16.9	16.0	16.7	16.2	16.2	16.6
1805 MHz	16.1	17.0	15.9	16.8	15.8	16.7	15.8	16.2	15.8	15.6	15.8	15.3	15.8	15.3
1843 MHz	17.0	16.8	16.8	16.2	16.7	16.5	17.2	17.6	17.5	18.6	17.5	18.6	16.9	17.4
1850 MHz	17.6	17.0	17.4	16.4	17.1	16.2	17.6	17.0	18.2	18.5	18.3	18.6	17.7	17.6
1880 MHz	17.6	16.3	17.4	16.4	18.9	17.7	19.8	19.7	18.6	18.5	17.9	17.6	16.7	16.6

Table 6—Complete dataset upper sidelobe suppression, peak to 20°.

The set of measured values is finally statistically analyzed to determine the specification:

- The array containing all the values in the table above counts 126 elements (9 frequencies x 7 tilts x 2 polarizations).
- The minimum value is 14.9 dB and the maximum is 19.8 dB. The mean is the sum of all the elements (as linear numbers) divided by 126.
- In the table above the higher the number, the smaller the sidelobe, the better the antenna's performance. To define the parameter 16% of the worst cases (lower values) are ruled out.
- The proportion $(126 - 1) : 100 = (x - 1) : 16$ solved by x, returns $x = 21$. Where x is the array index of the 16th percentile.
- Since 21 is an integer number, no interpolation is necessary.
- Once the array is sorted in ascending fashion, it can be seen that the 21st element (index = 21) is 15.8 dB.

Upper sidelobe suppression, peak to 20°	# Array elements	Min = Worst	Max = Best	16%
1710-1880 MHz	126	14.9 dB	19.8 dB	15.8 dB

Table 7—Summary of upper sidelobe suppression, peak to 20° statistics.

The specification is set as:

Type: Statistical	1710-1880 MHz
Upper sidelobe suppression, peak to 20°	> 15.8

Note that the specification values are never lower than 3 dB higher than the minimum found through the algorithm.

As previously state, in this example, the Upper sidelobe suppression, peak to 20° has only been calculated for one sub-band (1710-1880 MHz).

This procedure has to be repeated two additional times to populate the full specification table for the Upper sidelobe suppression, peak to 20° parameter:

Type: Statistical	1710-1880 MHz	1850-1990 MHz	1920-2170 MHz
Upper sidelobe suppression, peak to 20°	> 15.8	> 16.1	> 17.9

For the purpose of this whitepaper, it is instructive to show the plotted the Upper sidelobe suppression, peak to 20° values as a function of frequency, and the distribution of the calculated values in a histogram. These plots are shown below:

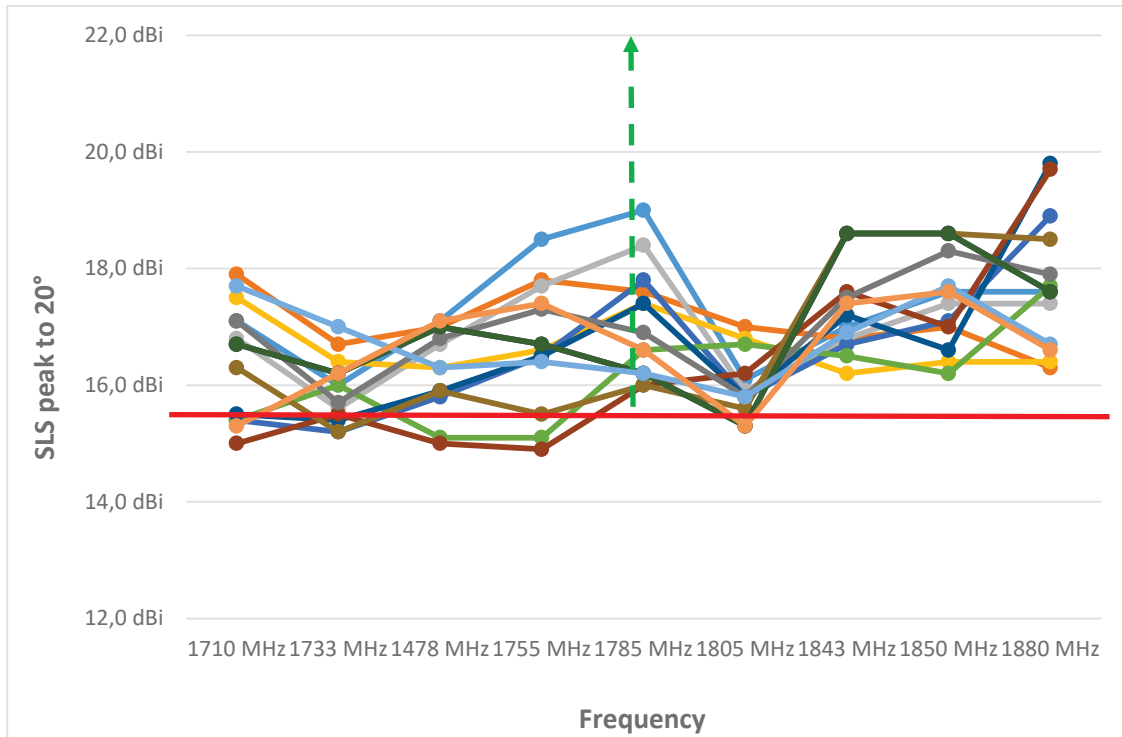

Figure 41—Upper sidelobe suppression, peak to 20° for each tilt and port as a function of the frequency.

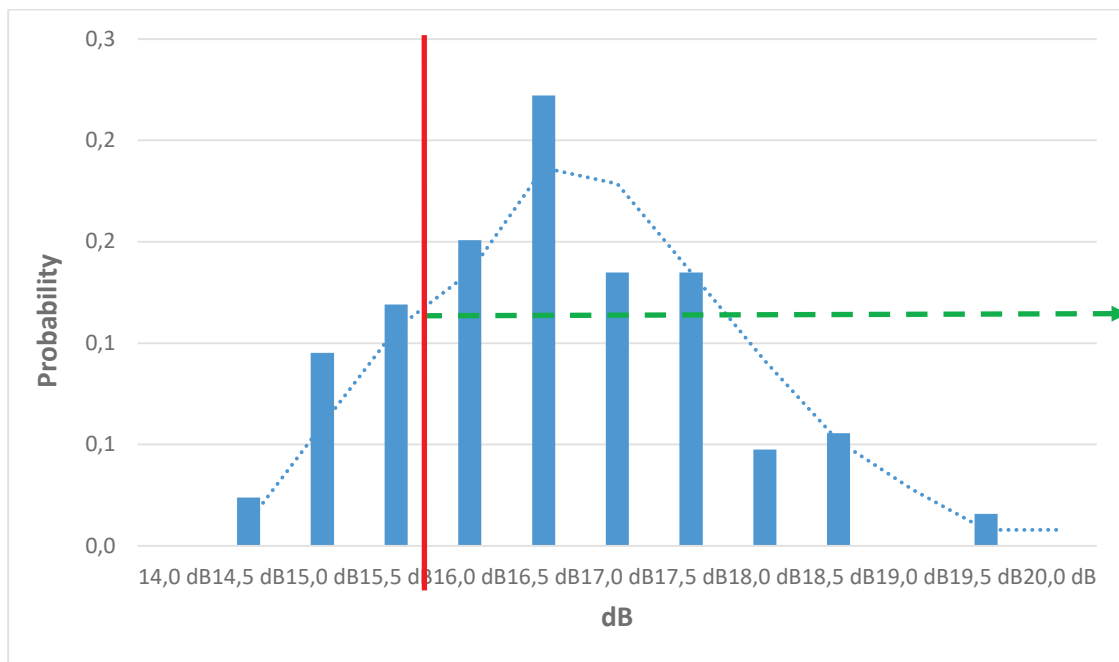

Figure 43—Histogram Upper sidelobe suppression, peak to 20°.

The histogram above shows well that the distribution of the values is not Gaussian. If the parameter would have been incorrectly calculated as $\mu-\sigma$, it would have been equal to 15.7 dB.

4.5 Sidelobe Suppression Calculation and Validation

The calculation of all the parameters related to the sidelobes (in this paper: “first sidelobe suppression”, “null fill”, “upper sidelobe suppression, peak to 20°” and “upper sidelobe suppression, horizon to 20°”) is only apparently uncomplicated, due to the fact that not all the sidelobes’ peaks are displayed as relative maxima in the elevation pattern. It is in fact possible that some of them (especially the first sidelobe above and/or below the main beam) are “merged” to another one (rare) or to the main beam (common). Should this eventuality occur, the sidelobe peak would at best be visible as an inflection point, but it could alternatively not be visible at all.

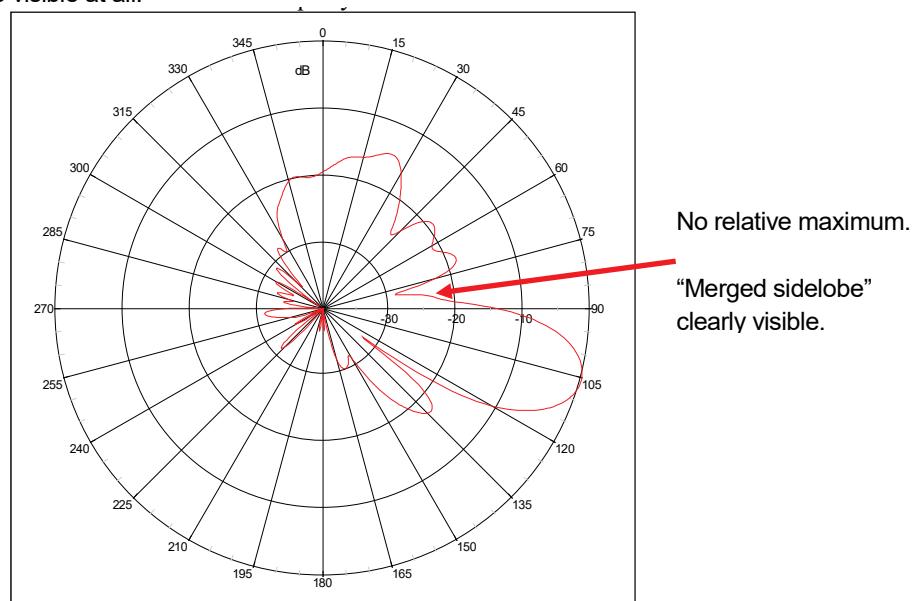

Figure 44—First upper sidelobe merged into main beam.

It is necessary to address this issue from the perspective of an automated calculation process, rather than relying on a visual analysis of the elevation pattern. On this wise some algorithms for the correct calculation of the above mentioned parameters will be described in the forthcoming paragraphs.

4.5.1 First Sidelobe Suppression

Several empirical tests were conducted amongst a number of antennas with different performances and characteristics, and those suggested that the first sidelobe above (*counterclockwise in the elevation pattern*) the main beam commonly appeared as a relative maximum in a sector equal to the V_{HPBW} multiplied by 1.78 above the main beam peak. For all the remaining cases where the elevation pattern did not exhibit any relative maximum in that sector, the tests showed a very high probability that the peak of a merged sidelobe could be found by, or immediately in proximity to, the angular direction corresponding to $V_{HPBW} * 1.55$ degrees above the main beam peak.

Consequently, the first sidelobe peak shall be determined by executing the following steps for each frequency, tilt and polarization involved in the calculation:

- Locate main beam’s maximum in the elevation pattern.

- Locate the first relative minimum above main beam's maximum.
- Locate the first relative maximum above the first relative minimum.
- Calculate the V_{HPBW} .
- If the angular position of the first relative maximum lies in the range delimited by the main beam peak and the angular direction represented by $1.78 * V_{HPBW}$ degrees above it, then the corresponding pattern level shall be selected as the peak of the first sidelobe above the main beam peak.
- If the angular position of the first relative maximum lies above the sector defined in the previous point, then the pattern level corresponding to the angular position marked by $1.55 * V_{HPBW}$ degrees above the main beam peak shall represent the level of the (merged) first sidelobe above the main beam peak.

Note: The above mentioned tests were conducted using a resolution of 0.5° in the elevation pattern, and with a set of antennas, whose V_{HPBW} never exceeded a broadness of 20 degrees.

4.5.2 Null fill

According to the definition in Section 3.3.3, the null fill parameter estimates the pattern level of the first relative minimum below (*clockwise in the elevation pattern*) the main beam. Comparably to what happens for the first sidelobe suppression (see previous paragraph), it is possible that merged sidelobes show up in the section of the elevation pattern situated below the main beam peak. In this case the first null does not appear as a relative minimum, but coincides with the peak of the merged sidelobe, as its angular position matches the end of the main beam. The aforementioned tests within the same conditions (see previous paragraph and the note at its foot), have proven to be valid for the first sidelobe below the main beam peak too, consequently the steps to execute in order to determine the null fill are the following ones:

- Locate main beam's maximum in the elevation pattern.
- Locate the first relative minimum below main beam's maximum.
- Locate the first relative maximum above the first relative minimum.
- Calculate the V_{HPBW} .
- If the angular position of the first relative maximum lies in the range delimited by the main beam peak and the angular direction represented by $1.78 * V_{HPBW}$ degrees below it, then the corresponding pattern level shall represent the peak of the first sidelobe below the main beam peak. In this case the null fill shall correspond to the relative minimum found before (second point of this list).
- If the angular position of the first relative maximum lies outside the sector defined in the previous point, then the beam level corresponding to the angular position marked by $1.55 * V_{HPBW}$ degrees below the main beam peak shall represent the level of the (merged) first sidelobe below the main beam peak. The null fill shall have, in this case, the same value of the peak of the first sidelobe below the main beam peak.

4.5.3 Upper Sidelobe Suppression, Peak to 20° / Horizon to 20°

As stated in Section 3.2.15 and Section 3.3.12, the "upper sidelobe suppression, peak to 20° " and the "upper sidelobe suppression, horizon to 20° " estimate the worst level of a sidelobe inside their appropriate sectors defined in the elevation pattern.

Yet, especially for antenna beams that have a very broad V_{HPBW} (e.g.: mechanically short antennas at low frequencies), it can happen that there is no sidelobe peak in the sector delimited by the main beam peak and 20 degrees above (*counterclockwise in the elevation pattern*) it or by the horizon and 20 degrees above (*counterclockwise in the elevation pattern*) it.

In these cases, only one of the following three circumstances can occur:

- In the analyzed sector there is only the first merged sidelobe peak.

- In the analyzed sector there is only a portion of a sidelobe.
- In the analyzed sector there only the main beam is contained.

For each of these circumstances there is an appropriate method to calculate the correct value for the parameter to evaluate. Respectively:

- The first merged sidelobe peak is treated as any other sidelobe peak. Since it does lie in the sector under observation, the specification of the studied parameter shall be in fact equal to the first merged sidelobe peak value.
- The specification of the studied parameter shall be equal to the highest level of the portion of the sidelobe included in the sector under observation.
- The specification of the studied parameter shall be temporarily set to “not available”.

A deeper analysis is required in case one or more measurement points appear as “not available”. After having calculated the specification for all the measurement points (one for each combination of frequency, tilt and polarization), it is necessary to determine the quantity of “not available” data in respect to the one that has been associated to a numeric value instead. If the “not available” are more than 50% of the whole dataset, then the statistical evaluation of the parameter is skipped, and its specification shall be instead set to “**not applicable**”. On the contrary, if there are at least 50% of numeric values in the above mentioned dataset, then all the “not available” shall be substituted by 22 dB and the statistical evaluation of the parameter is performed as usual.

Note: The value of 22 dB has been selected after a research on the “upper sidelobe suppression, peak to 20°” and “upper sidelobe suppression, horizon to 20°” specifications. This value appeared to be the one most of the measurement points lean to. It has also been proven, that the substitutions of 22 dB to the “not applicable” don’t polarize much the single-sided statistical evaluation of the above mentioned parameters, which means that this value lets the performance of the antenna remain accurate enough.

4.6 Gain Validation

Gain values are typically determined by the “gain by substitution” method, or the “gain by directivity / loss” method (see Section 9.3 for their description). Both can be used to validate the specification of the gain, and the validation process described below is applicable to the dataset of the parameter generated by either method.

The gain specification is based on the values measured on all relevant ports, over the specified sub-band frequency ranges, and at the low, mid, and high electrical downtilt settings. A “gain over all tilts” is also specified, and it is calculated using measurements over all the antenna electrical downtilt values. In other words, gain is to be specified in two ways:

- At the specific minimum, middle, and maximum values of an antenna’s tilt range. In this case, the validation data for each specified tilt is analyzed only at that tilt, not within a range of tilt degrees.
- Over all tilts of an antenna’s tilt range. In this case, the validation data is analyzed over the entire tilt range as measured in specific increments of electrical downtilt (see Section 4.2).

Gain measurements shall be carried out carefully to ensure their certainty. They can be difficult to be precisely repeated, because the accuracy and repeatability of those measurements is determined by a number of factors (this is better described in Section 9.4). Industry experts outline the discrepancy between gain measurements as a number that oscillates between 0.5 dB and 1.0 dB. The repeatability margin specification recommended for gain in this whitepaper is 0.8 dB, which is a value based on the experience of the above mentioned experts, and is applied to all the antennas covered by this document, measured on all calibrated antenna ranges, at any time, in good environmental conditions.

4.6.1 Gain Validation for a Single Tilt Value

For this example of validation process, the calculation of the gain specification in the 1710-1880 MHz sub-band and by 0 degrees of electrical tilt will be used.

Gain			
Type: Statistical	1710-1880 MHz	1850-1990 MHz	1920-2170 MHz
0 Tilt	17.1	17.4	17.7
5 Tilt	17.3	17.5	17.7
10 Tilt	17.0	17.0	17.2

First of all, the antennas radiation patterns for the sub-band are analyzed according to the parameter definition (see Section 3.2.3). The values for gain are measured for each frequency in the sub-band, each port, and 0 degrees of electrical downtilt:

Total Gain, dBi									
	1.71	1.733	1.748	1.755	1.785	1.805	1.843	1.85	1.88
L-PORT DEG:0	17.44	17.22	17.08	17.08	17.20	17.08	16.85	16.85	16.97
R-PORT DEG:0	16.88	16.91	16.93	16.98	17.25	17.14	17.20	17.29	17.30
Overall	Min	Max	Mean						
1710 - 1880 MHz	16.85	17.44	17.09						

Table 6—Complete dataset for gain (1710-1880 MHz, 0° tilt).

The set of measured values is finally statistically analyzed to determine the specification (in this case the mean, which shall be calculated over the magnitude and then reconverted in dBi):

Total Gain, dBi	Min	Max	Mean
1710-1880 MHz	16.9	17.4	17.1

Table 7—Summary of gain statistics (1710 – 1880 MHz, 0° tilt).

The specification is finally set to 17.1 dBi.

As previously state, in this example, the gain has only been calculated for one sub-band (1710-1880 MHz).

This procedure has to be repeated two additional times to populate the full specification table for the gain parameter by 0 degrees of electrical downtilt:

Type: Statistical	All ports	1710-1880 MHz	1850-1990 MHz	1920-2170 MHz
Gain	0 Tilt	17.1	17.4	17.7

The same has to be done for the other two tilts (middle and maximum, being 0° the minimum):

Type: Statistical	All ports	1710-1880 MHz	1850-1990 MHz	1920-2170 MHz
Gain	0 Tilt	17.1	17.4	17.7
	5 Tilt	17.3	17.5	17.7
	10 Tilt	17.0	17.0	17.2

Per this whitepaper’s guidelines, the repeatability margin associated with a 17.1 dBi gain specification is 17.1 dBi – 0.8 dBi, or 16.3 dBi.

For the purpose of this whitepaper, it is instructive to show the plotted the gain values as a function of frequency, the distribution of the calculated values in a histogram, and the gain with its repeatability margin. These plots are shown below:

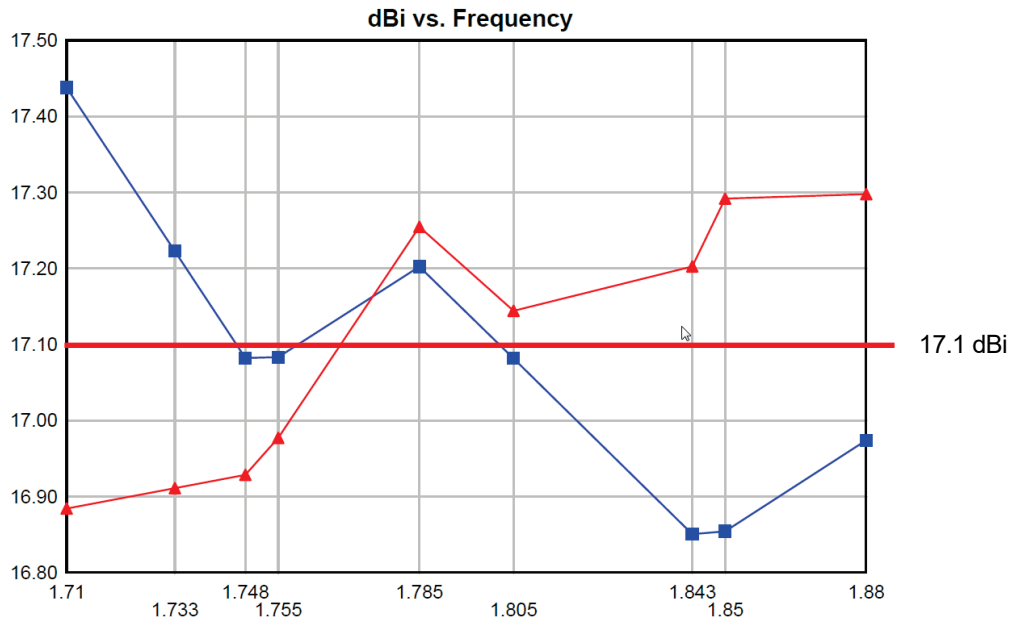

Figure 45—Gain plot for 0° tilt, both ports.

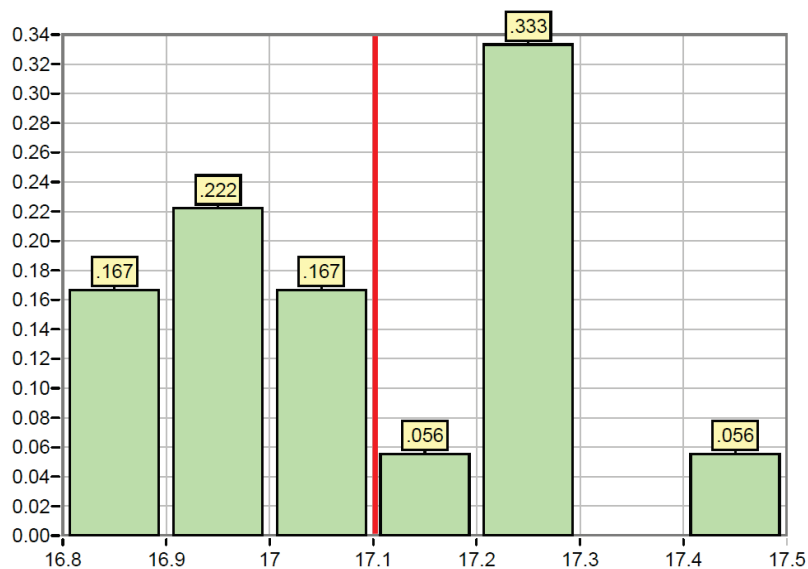

Figure 46—Gain histogram.

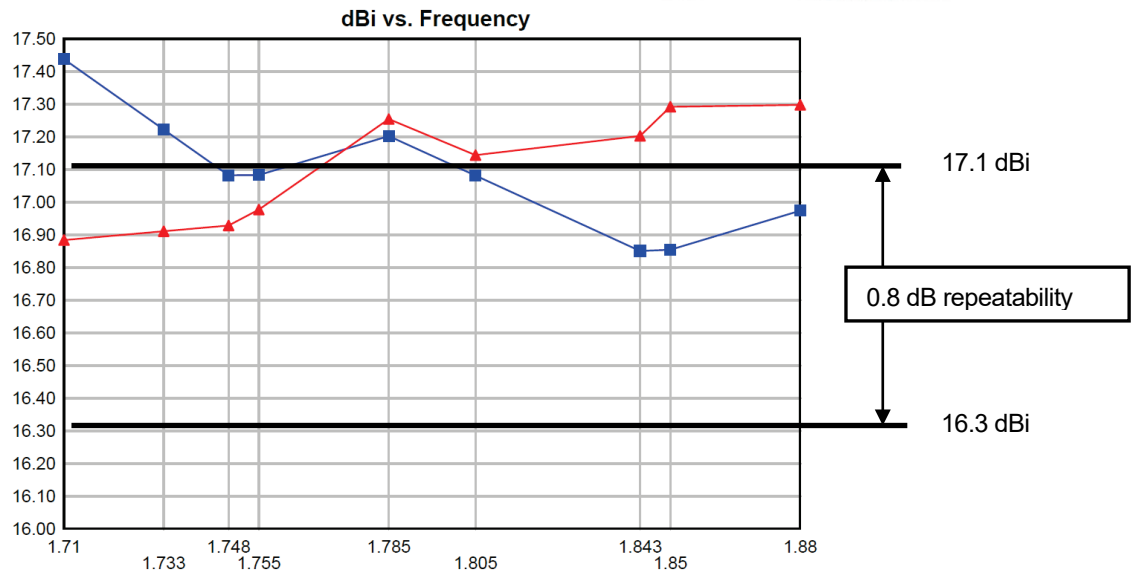

Figure 47—Gain plot with repeatability margin.

4.6.2 Gain Over All Tilts Validation

In this specification the gain is averaged for all values of the tilt range (see Section 4.2 for an explanation of “all values of the tilt range”). For this example of validation process, the calculation of the “gain over all tilts” specification in the 1850-1990 MHz sub-band will be used.

First of all, the antennas radiation patterns for the sub-band are analyzed according to the parameter definition (see Section 3.2.3). The values for gain are measured for each frequency in the sub-band, each port, and the whole range of electrical downtilt.

El. Tilt	2.5	2.5	3.0	3.0	4.0	4.0	5.0	5.0	6.0	6.0	7.0	7.0	8.0	8.0	9.0	9.0	10.0	10.0	11.0	11.0	12.0	12.0
Polarization	+45°	-45°	+45°	-45°	+45°	-45°	+45°	-45°	+45°	-45°	+45°	-45°	+45°	-45°	+45°	-45°	+45°	-45°	+45°	-45°	+45°	-45°
1850 MHz	17.7	17.4	17.7	17.4	17.7	17.4	17.7	17.5	17.7	17.5	17.7	17.5	17.6	17.4	17.5	17.3	17.4	17.3	17.3	17.2	17.1	17.1
1880 MHz	17.7	17.6	17.8	17.7	17.8	17.7	17.8	17.6	17.8	17.6	17.7	17.5	17.5	17.4	17.4	17.3	17.3	17.3	17.2	17.2	17.1	17.1
1910 MHz	17.5	17.5	17.5	17.5	17.5	17.4	17.5	17.3	17.5	17.2	17.4	17.2	17.4	17.2	17.4	17.2	17.4	17.2	17.3	17.1	17.3	17.1
1920 MHz	17.5	17.5	17.5	17.4	17.5	17.3	17.5	17.3	17.5	17.2	17.6	17.2	17.6	17.3	17.5	17.2	17.5	17.2	17.4	17.1	17.4	17.1
1930 MHz	17.6	17.4	17.6	17.4	17.6	17.3	17.6	17.3	17.6	17.3	17.7	17.3	17.7	17.3	17.6	17.3	17.6	17.2	17.5	17.2	17.5	17.2
1950 MHz	17.6	17.4	17.6	17.4	17.7	17.4	17.8	17.4	17.8	17.4	17.9	17.4	17.8	17.4	17.8	17.3	17.7	17.2	17.7	17.2	17.5	17.1
1960 MHz	17.6	17.5	17.6	17.5	17.7	17.5	17.8	17.5	17.8	17.5	17.8	17.5	17.8	17.5	17.8	17.4	17.7	17.3	17.6	17.2	17.4	17.1
1980 MHz	17.7	17.7	17.7	17.6	17.7	17.6	17.7	17.6	17.7	17.5	17.7	17.5	17.6	17.5	17.6	17.4	17.5	17.3	17.3	17.1	17.0	16.9
1990 MHz	17.8	17.7	17.7	17.7	17.7	17.6	17.7	17.6	17.6	17.5	17.5	17.5	17.5	17.4	17.4	17.3	17.3	17.2	17.1	17.0	17.0	16.9

Table 8—Complete dataset of gain.

The set of measured values is finally statistically analyzed to determine the specification:

- The array containing all the values above counts 198 elements (9 frequencies x 11 tilts x 2 polarizations).
- The minimum value is 16.9 dBi and the maximum is 17.9 dBi. The mean is the sum of all the elements in magnitude divided by 198 and then reconverted in dB.
- The proportion $(198 - 1) : 100 = (x - 1) : 6.7$ solved by x, returns $x = 14.2$. Where x is the array index of the 6.7th percentile.

- The proportion $(198 - 1) : 100 = (x - 1) : 93.3$ solved by x, returns $x = 184.8$. Where x is the array index of the 93.3rd percentile.
- Once the array is sorted in ascending fashion, it can be seen that the 14th (index = 14) and 15th elements are both 17.1 dBi, while the 184th and 185th are both 17.8 dBi.
- Clearly, the “mean + tolerance” value is 17.8 dBi, while “mean - tolerance” value is 17.1 dBi.
- The modulus of the differences of the two values from the mean is respectively: 0.3 dB and 0.4 dB, therefore **the tolerance is their average, which is 0.3 dB.**

Gain over all tilts	# Array elements	Min	Max	Mean	Tolerance
1850-1990 MHz	198	16.9 dBi	17.9 dBi	17.5 dBi	0.3 dBi

Table 9—Summary of gain statistics, over all tilts, 1850-1990 MHz.

The specification is set by the rounding of the mean value to 17.5 dBi and the rounding of the tolerance to 0.3 dB:

Type: Statistical	All ports	1850-1990 MHz
Gain	Over all tilts	17.5 dBi ± 0.3 dB

As previously state, in this example, the gain over all tilts has only been calculated for one sub-band (1850-1990 MHz).

This procedure has to be repeated two additional times to populate the full specification table for the parameter:

Type: Statistical	All ports	1710-1880 MHz	1850-1990 MHz	1920-2170 MHz
Gain	Over all tilts	17.4 ± 0.2	17.5 ± 0.3	17.9 ± 0.3

Below a table of the whole gain specification:

Type: Statistical	All ports	1710-1880 MHz	1850-1990 MHz	1920-2170 MHz
Gain	0 Tilt	17.1	17.4	17.7
	5 Tilt	17.3	17.5	17.7
	10 Tilt	17.0	17.0	17.2
	Over all tilts	17.4 ± 0.2	17.5 ± 0.3	17.9 ± 0.3

For the purpose of this whitepaper, it is instructive to show the plotted gain over all tilts values as a function of frequency, and the distribution of the calculated values in a histogram. These plots are shown below:

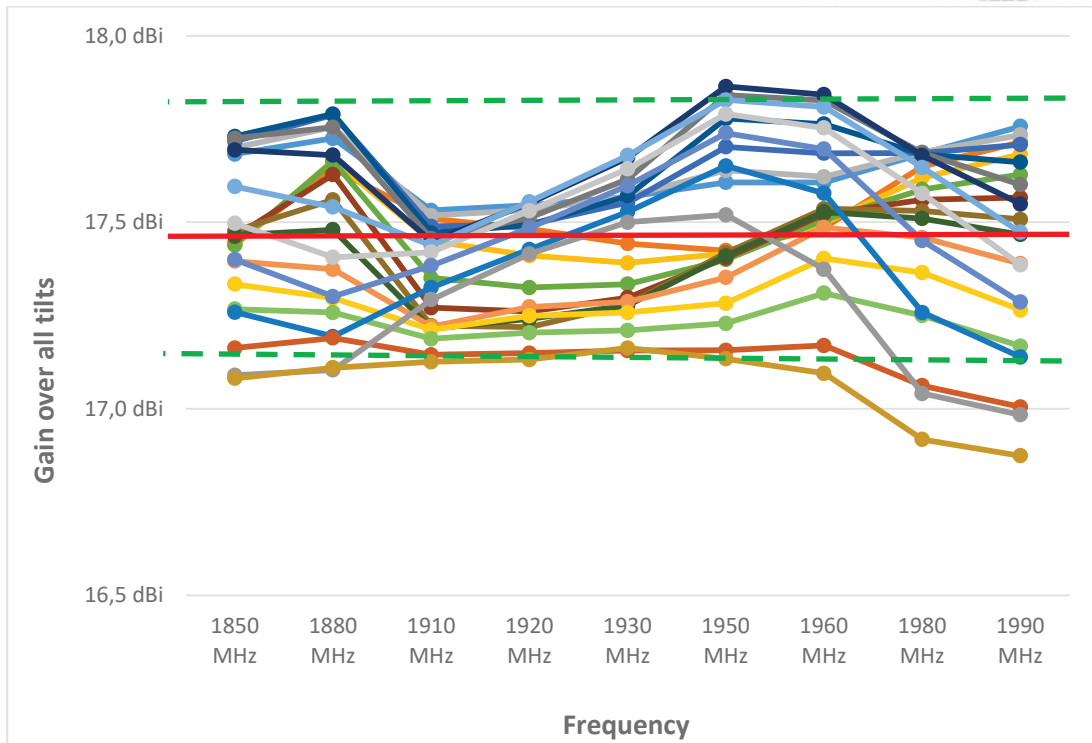

Figure 48—Gain for each tilt and port as a function of the frequency.

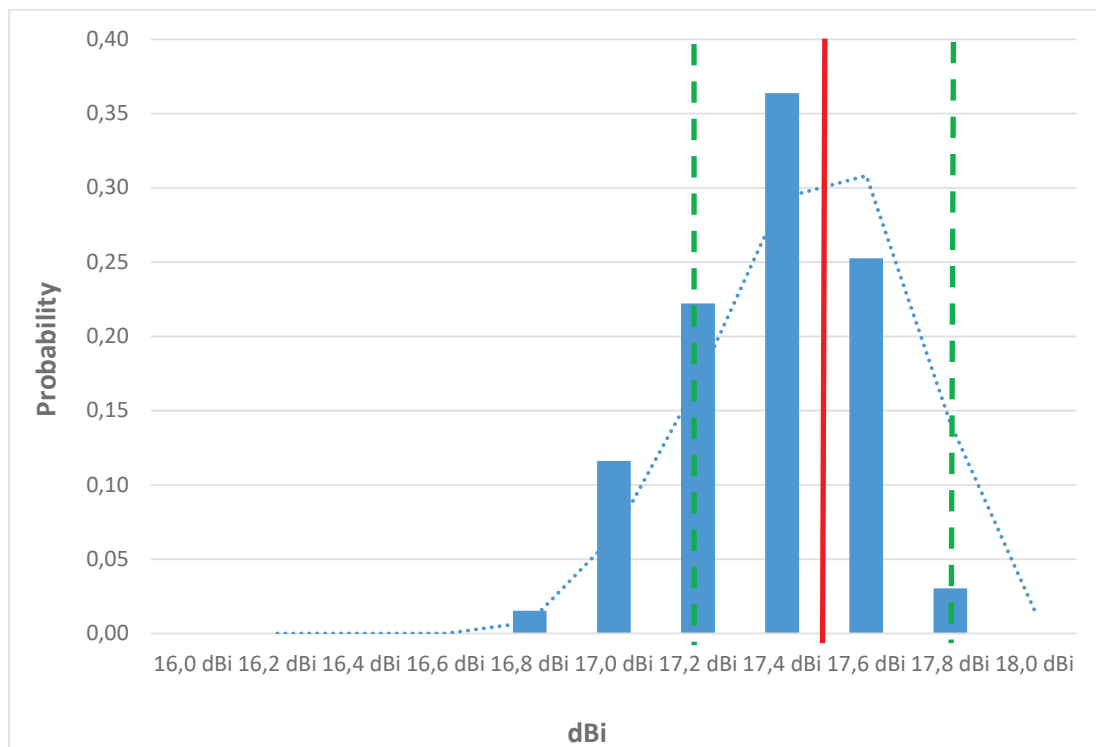

Figure 49—Gain histogram.

The repeatability margin value of 0.8 dBi is graphed below:

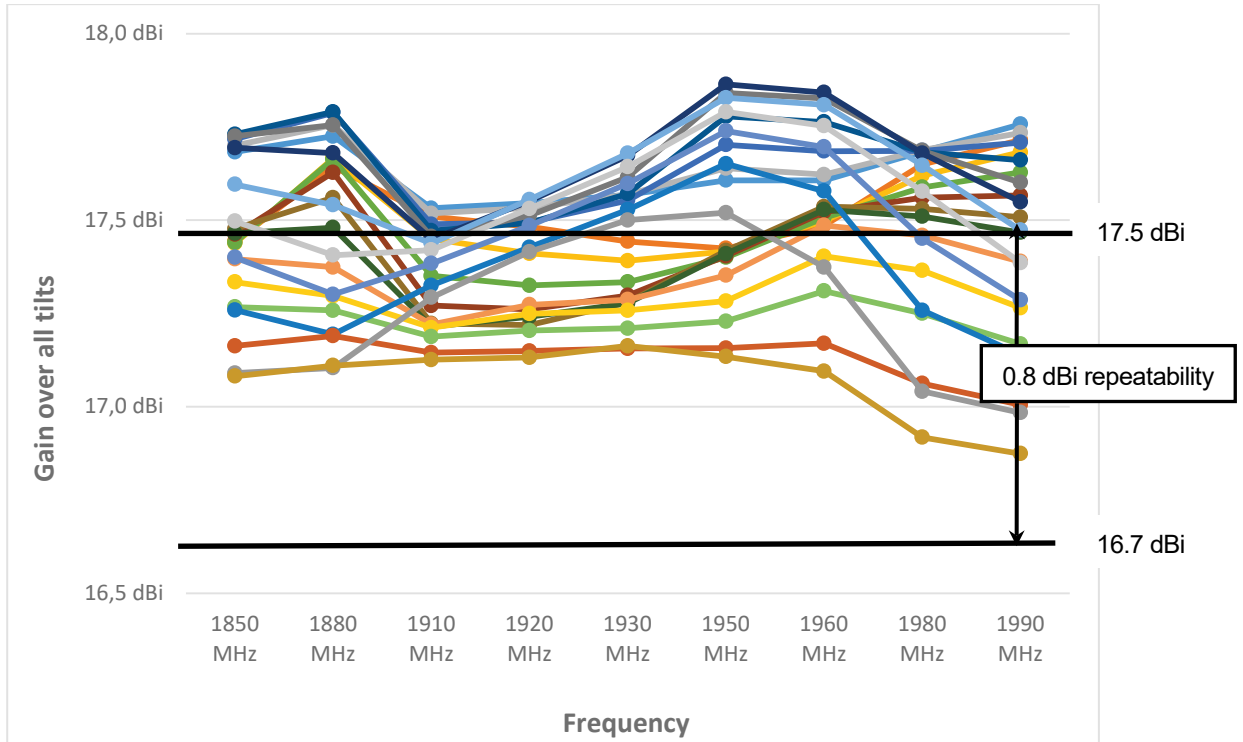

Figure 50—Gain plot with repeatability margin.

The histogram above shows well that the distribution of the values is not Gaussian, even if the tolerance incorrectly calculated as $1.5 \cdot \sigma$ would have had the same value of 0.3 dB.

4.7 Validation of Elevation Downtilt Deviation

For this example of the validation process, the calculation of the elevation downtilt deviation specification in the antenna sub-bands of 1710-1880 MHz, 1850-1990 MHz, and 1920-2170 MHz will be used.

First of all, the antennas radiation patterns for the sub-bands are analyzed according to the parameter definition (see Section 3.2.7). The values for the real electrical downtilt are measured (see Section 3.2.6) for each frequency in the sub-band, each port, and the whole range of electrical downtilt.

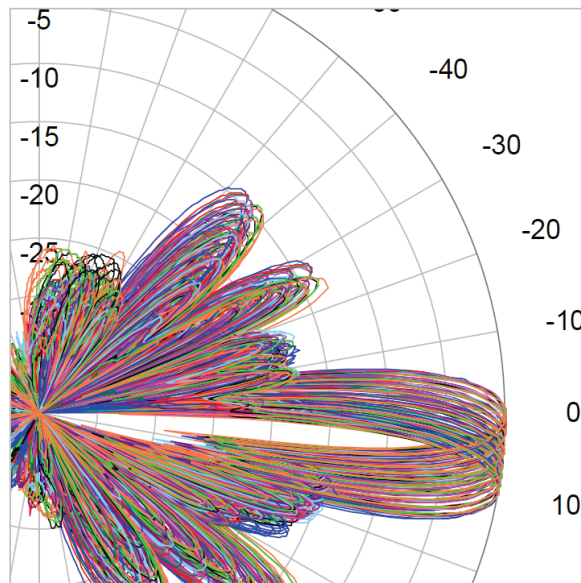

Figure 51—Elevation pattern plots – 1710-1880 MHz, all ports, and all tilts.

For each tilt degree, the real elevation electrical downtilt is compared to its nominal value, and the absolute maximum differences (deviations) between those two are calculated:

Measured beam peak value

Absolute deviation from nominal tilt setting

	1710	1732,5	1747,5	1755	1785	1805	1842,5	1850	1880	1910	1920	1930	1950	1960	1980	1990	2110	2132,5	2140	2155	2170	
	MHz	MHz	MHz	MHz	MHz	MHz	MHz	MHz	MHz	MHz	MHz	MHz	MHz	MHz	MHz	MHz	MHz	MHz	MHz	MHz	MHz	
Electrical tilt [°], port 1																						
EDT 0°	-0,3	-0,3	-0,3	-0,3	-0,3	-0,4	-0,3	-0,4	-0,4	-0,4	-0,3	-0,3	-0,3	-0,5	-0,5	-0,5	-0,4	-0,4	-0,4	-0,4	-0,4	-0,4
Nominal dev.	0,3	0,3	0,3	0,3	0,3	0,4	0,3	0,4	0,4	0,4	0,3	0,3	0,3	0,5	0,5	0,5	0,4	0,4	0,4	0,4	0,4	0,4
EDT 1°	-1,4	-1,5	-1,5	-1,7	-1,7	-1,5	-1,4	-1,6	-1,6	-1,3	-1,2	-1,2	-1,2	-1,5	-1,5	-1,3	-1,2	-1,3	-1,4	-1,4	-1,4	-1,4
Nominal dev.	0,4	0,5	0,5	0,7	0,7	0,5	0,4	0,6	0,6	0,3	0,2	0,2	0,2	0,5	0,5	0,3	0,2	0,3	0,4	0,4	0,4	0,4
EDT 2°	-2,3	-2,4	-2,4	-2,7	-2,7	-2,5	-2,4	-2,6	-2,6	-2,2	-2,2	-2,2	-2,2	-2,5	-2,5	-2,3	-2,2	-2,2	-2,2	-2,2	-2,2	-2,0
Nominal dev.	0,3	0,4	0,4	0,7	0,7	0,5	0,4	0,6	0,6	0,2	0,2	0,2	0,2	0,5	0,5	0,3	0,2	0,2	0,2	0,2	0,0	0,0
EDT 3°	-3,1	-3,2	-3,2	-3,4	-3,4	-3,3	-3,2	-3,5	-3,5	-3,1	-3,3	-3,3	-3,3	-3,4	-3,4	-3,3	-3,3	-3,3	-3,3	-3,3	-3,3	-3,1
Nominal dev.	0,1	0,2	0,2	0,4	0,4	0,3	0,2	0,5	0,5	0,1	0,3	0,3	0,3	0,4	0,4	0,3	0,3	0,3	0,3	0,3	0,3	0,1
EDT 4°	-4,1	-4,3	-4,3	-4,4	-4,4	-4,4	-4,3	-4,4	-4,4	-4,2	-4,3	-4,3	-4,3	-4,2	-4,2	-4,2	-4,3	-4,3	-4,2	-4,2	-4,2	-4,3
Nominal dev.	0,1	0,3	0,3	0,4	0,4	0,4	0,3	0,4	0,4	0,2	0,3	0,3	0,3	0,2	0,2	0,2	0,3	0,3	0,2	0,2	0,2	0,3
EDT 5°	-5,1	-5,3	-5,3	-5,2	-5,2	-5,3	-5,3	-5,2	-5,2	-5,3	-5,4	-5,4	-5,4	-5,1	-5,1	-5,1	-5,2	-5,1	-4,9	-4,9	-5,2	-5,2
Nominal dev.	0,1	0,3	0,3	0,2	0,2	0,3	0,3	0,2	0,2	0,3	0,4	0,4	0,4	0,1	0,1	0,1	0,2	0,1	0,1	0,1	0,1	0,2
EDT 6°	-5,9	-6,0	-6,0	-5,9	-5,9	-6,0	-6,2	-6,0	-6,0	-6,2	-6,3	-6,3	-6,3	-5,9	-5,9	-6,0	-6,1	-6,2	-6,0	-6,0	-6,3	-6,3
Nominal dev.	0,1	0,0	0,0	0,1	0,1	0,0	0,2	0,0	0,0	0,2	0,3	0,3	0,3	0,1	0,1	0,0	0,1	0,2	0,0	0,0	0,3	0,3
EDT 7°	-6,8	-6,8	-6,8	-6,7	-6,7	-6,9	-7,0	-6,9	-6,9	-7,1	-7,2	-7,2	-7,2	-6,8	-6,8	-6,9	-7,0	-7,1	-6,9	-6,9	-7,1	-7,1
Nominal dev.	0,2	0,2	0,2	0,3	0,3	0,1	0,0	0,1	0,1	0,1	0,2	0,2	0,2	0,2	0,2	0,2	0,1	0,0	0,1	0,1	0,1	0,1
EDT 8°	-8,0	-8,0	-8,0	-7,8	-7,8	-8,0	-8,1	-8,0	-8,0	-8,1	-8,0	-8,0	-8,0	-7,8	-7,8	-7,8	-7,9	-8,0	-7,8	-7,8	-7,9	-7,9
Nominal dev.	0,0	0,0	0,0	0,2	0,2	0,0	0,1	0,0	0,0	0,1	0,0	0,0	0,0	0,2	0,2	0,2	0,1	0,0	0,2	0,2	0,1	0,1
Electrical tilt [°], port 2																						
EDT 0°	-0,3	-0,3	-0,3	-0,3	-0,3	-0,4	-0,3	-0,3	-0,3	-0,2	-0,2	-0,2	-0,2	-0,4	-0,4	-0,3	-0,3	-0,3	-0,3	-0,3	-0,3	-0,3
Nominal dev.	0,3	0,3	0,3	0,3	0,3	0,4	0,3	0,3	0,3	0,2	0,2	0,2	0,2	0,4	0,4	0,3	0,3	0,3	0,3	0,3	0,3	0,3
EDT 1°	-1,3	-1,4	-1,4	-1,7	-1,7	-1,5	-1,3	-1,3	-1,3	-1,0	-1,2	-1,2	-1,2	-1,5	-1,5	-1,2	-1,1	-1,2	-1,2	-1,2	-1,1	-1,1
Nominal dev.	0,3	0,4	0,4	0,7	0,7	0,5	0,3	0,3	0,3	0,0	0,2	0,2	0,2	0,5	0,5	0,2	0,1	0,2	0,2	0,2	0,1	0,1
EDT 2°	-2,1	-2,3	-2,3	-2,6	-2,6	-2,4	-2,3	-2,3	-2,3	-1,9	-2,1	-2,1	-2,1	-2,4	-2,4	-2,1	-2,0	-2,0	-2,1	-2,1	-1,9	-1,9
Nominal dev.	0,1	0,3	0,3	0,6	0,6	0,4	0,3	0,3	0,3	0,1	0,1	0,1	0,1	0,4	0,4	0,1	0,0	0,0	0,1	0,1	0,1	0,1
EDT 3°	-2,8	-3,0	-3,0	-3,3	-3,3	-3,2	-3,1	-3,1	-3,1	-2,8	-3,1	-3,1	-3,1	-3,2	-3,2	-3,0	-3,0	-3,0	-3,1	-3,1	-2,9	-2,9
Nominal dev.	0,2	0,0	0,0	0,3	0,3	0,2	0,1	0,1	0,1	0,2	0,1	0,1	0,1	0,2	0,2	0,0	0,0	0,0	0,1	0,1	0,1	0,1
EDT 4°	-4,0	-4,2	-4,2	-4,3	-4,3	-4,3	-4,2	-4,2	-4,2	-4,1	-4,2	-4,2	-4,2	-4,1	-4,1	-4,1	-4,2	-4,2	-4,1	-4,1	-4,1	-4,1
Nominal dev.	0,0	0,2	0,2	0,3	0,3	0,3	0,2	0,2	0,2	0,1	0,2	0,2	0,2	0,1	0,1	0,1	0,2	0,2	0,1	0,1	0,1	0,1
EDT 5°	-5,0	-5,1	-5,1	-5,1	-5,1	-5,3	-5,3	-5,2	-5,2	-5,3	-5,2	-5,2	-5,2	-4,9	-4,9	-5,0	-5,2	-5,1	-4,9	-4,9	-5,1	-5,1
Nominal dev.	0,0	0,1	0,1	0,1	0,1	0,3	0,3	0,2	0,2	0,3	0,2	0,2	0,2	0,1	0,1	0,0	0,2	0,1	0,1	0,1	0,1	0,1
EDT 6°	-5,8	-5,9	-5,9	-5,9	-5,9	-6,0	-6,2	-6,0	-6,0	-6,2	-6,2	-6,2	-6,2	-5,8	-5,8	-6,0	-6,2	-6,2	-6,0	-6,0	-6,1	-6,1
Nominal dev.	0,2	0,1	0,1	0,1	0,1	0,0	0,2	0,0	0,0	0,2	0,2	0,2	0,2	0,2	0,2	0,0	0,2	0,2	0,0	0,0	0,1	0,1
EDT 7°	-6,8	-6,9	-6,9	-6,8	-6,8	-7,0	-7,1	-7,0	-7,0	-7,1	-7,1	-7,1	-7,1	-6,8	-6,8	-7,0	-7,1	-7,1	-7,0	-7,0	-7,1	-7,1
Nominal dev.	0,2	0,1	0,1	0,2	0,2	0,0	0,1	0,0	0,0	0,1	0,1	0,1	0,1	0,2	0,2	0,0	0,1	0,1	0,0	0,0	0,1	0,1
EDT 8°	-8,0	-8,1	-8,1	-7,9	-7,9	-8,0	-8,1	-8,0	-8,0	-8,1	-8,0	-8,0	-8,0	-7,9	-7,9	-7,8	-7,9	-8,0	-7,9	-7,9	-7,9	-7,9
Nominal dev.	0,0	0,1	0,1	0,1	0,1	0,0	0,1	0,0	0,0	0,1	0,0	0,0	0,0	0,1	0,1	0,2	0,1	0,0	0,1	0,1	0,1	0,1

Table 10—Complete dataset elevation downtilt deviation.

Note that the downtilts (real ones are those not marked in gray in the table above, nominal ones are those in the first column beside the “EDT” labels) shall be referenced to the mechanical boresight.

Below an example on how to calculate the deviation of a tilt from its nominal value:

EDT 7°	-6,8
Nominal dev.	0,2

At the 7° nominal electrical downtilt setting (EDT), the beam peak measures 6.8° (the minus indicates, in this table, only the fact that the beam is tilting down in respect to the horizon). Thus the deviation of the beam tilt is:

$$|\text{Nominal tilt} - \text{Real tilt}| = |7 - 6.8| = |0.2| = 0.2$$

Once the complete dataset of deviations is obtained, the parameter is statistically analyzed to calculate the specification. This is done no differently than the example in Section 4.4.6 for single-sided maximum parameters.

<i>Type: Statistical</i>	1710-1880 MHz	1850-1990 MHz	1920-2170 MHz
Elevation Downtilt Deviation	< 0.5	< 0.4	< 0.4

4.8 Guidance on Specifications Provided in Radio Planning Files

RF planning tool data file formats shall follow the same frequency and downtilt recommendations illustrated in this document, preferably to the recommended frequencies specified in Section 9.1.3. The gain parameter present in each pattern’s data file shall be equal to the actual measured gain determined when the pattern was taken. Note that this procedure is different from what already specified for the gain parameter.

5 Mechanical Parameters and Specifications

In this paper the mechanical parameters and the environmental specifications will always be, when not specifically otherwise written, intended as required.

The format used for the mechanical parameters will be the same used for electrical specifications.

5.1 Antenna Dimensions

Parameter Definition

- The outer antenna dimensions without additional antenna system components (e.g.: the mount or the RET unit).
- The dimensions are defined along the three axis of a Cartesian coordinate system defining the height (H), the width (W) and the depth (D) of the product (see figure 52).
- The antenna RET installation reference plane.

Specification Definition

- The antenna dimensions are its nominal values specified in millimeters.
- Assuming the antenna is oriented similar to its alignment on the tower prior any tilting:
 - Height is measured along the vertical direction of the antenna (typically this is also the largest dimension).
 - Width is measured along the horizontal direction of the antenna.
 - Depth is measured perpendicular to the plane spanned by vertical and horizontal direction.
 - The antenna RET installation reference plane is described by the H, W, or D dimension, but is actually the plane normal (or most normal) to it.
- Antennas that don’t support RETs shall not have their installation reference plane specified

Specification Example

- Antenna without RET support:
 - H x W x D: 1391mm x 183mm x 118mm.
 - A RET actuator cannot be attached to the antenna.
- Antenna with RET support:
 - H x W x D: 1391mm x 183mm x 118mm.

- A RET actuator interface is present on the bottom of the antenna along the plane normal to its height.

XML - Tag Example

```
<dimensions height="1391" width="183" depth="118"/>
<dimensions height="1391" width="183" depth="118" reference="H"/>
```

Relevance

- The antenna dimensions are relevant to plan detailed antenna installations regarding required space, required fixation points and visual impact.
- The antenna dimensions also impact the windload at a rated wind speed.

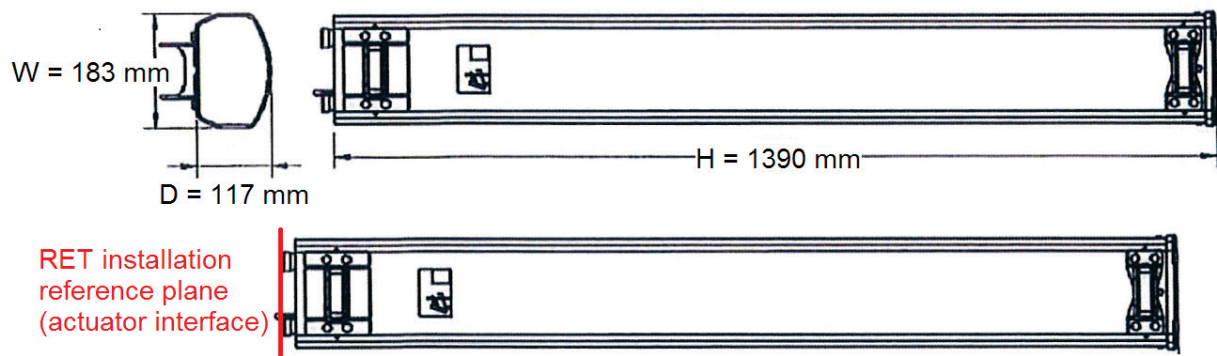

Figure 52—Antenna dimensions example.

5.2 Packing Size

Parameter Definition

- The outer dimensions of the packaged antenna.
- The dimensions are defined along the three axis of a Cartesian coordinate system defining the height (H), the width (W) and the depth (D) of the package.

Specification Definition

- The packaged antenna dimensions are its nominal values specified in millimeters.
- H, W and D shall be specified along the same directions of the unpacked antenna dimensions, irrespective of the orientation of the package during transport or storage.

Specification Example

- H x W x D - 1391mm x 350mm x 110 mm.

XML - Tag Example

```
<packing_size height="1500" width="400" depth="200"/>
```

Relevance

- The packaged antenna dimensions are relevant to plan and optimize transport and storage of the antenna.
- The package includes ordered components as mounting hardware, the accessories (e.g.: RET) or other options.

5.3 Net Weight

Parameter Definition

- The net weight of an antenna without mounting hardware or accessories or other options.
- The net weight of the individual antenna options as, for example, antenna mounting hardware (including all nuts, bolts and brackets of the corresponding variant) or the RET.

Specification Definition

- Nominal values in kilograms.
- Providing the individual values for both antenna and accessories provides all information on the weight required and avoids missing clarity of different kits or options.

Specification Example

- Weight without accessories = 14.5 kg.
- Weight of accessories only = 3.4 kg.

XML - Tag Example

```
<net_weight wo_mtg_hardware="14.5" only_mtg_hardware="3.4"/>
```

Relevance

- The antenna weight is relevant to plan detailed antenna installations regarding pole loading, transportation and installation work.

5.4 Shipping Weight

Parameter Definition

- The shipping weight of an antenna includes the antenna, its packaging and all other options put into the package (e.g.: the selected mount).

Specification Definition

- Nominal values in kilograms.

Specification Example

- Shipping weight = 3.4 kg.

XML - Tag Example

```
<shipping_weight value="22.5"/>
```

Relevance

- The antenna shipping weight is required for the logistics to manage shipping and storage of antennas.

5.5 Connector Type

Parameter Definition

- The antenna connector type specifies the RF connectors of the antenna, which can be attached to other system components (e.g.: feeder cables).

Specification Definition

- RF connectors follow standard nomenclature regarding their size and detail it with the male/female information. Selected options as long/short neck are also specified.

Specification Example

- Port 2 is a "7-16 female long neck" RF connector.

XML - Tag Example

```
<port name="2" polarization="-45" location="top" connector_type="7-16 female long neck"/>
```

Relevance

- The antenna connector types are relevant for the operators to ensure the system components can be connected with the antenna in an efficient way without the need for additional connectors or adapters.

5.6 Connector Quantity

Parameter Definition

- The connector quantity specifies the number of RF connector ports of the antenna, which directly depends on the number of bands and polarizations that are supported by the antenna itself.

Specification Definition

- The quantity is defined by the number of times that each unique port tag appears under each cluster.

Specification Example

- There are 2 “7-16 female” connectors at the bottom of the antenna and 2 “4.3-10 female” at its back, for a total of 4 RF connectors.

```
<cluster name="1st">
  <port name="1" polarization="+45" location="bottom" connector_type="7-16f"/>
  <port name="2" polarization="-45" location="bottom" connector_type="7-16f"/>
  [. . .]
<cluster name="n-th">
  <port name="n-1" polarization="+45" location="back" connector_type="4.3-10f"/>
  <port name="n" polarization="-45" location="back" connector_type="4.3-10f"/>
```

XML - Tag Example

- Not applicable

Relevance

- The antenna connectors define the input interfaces to connect the antenna to the rest of the systems. This is relevant for the operators to ensure that their system design matches the antenna input needs regarding the connections and different inputs.

5.7 Connector Position

Parameter Definition

- This parameter defines the position of the different RF connectors together with a marking of the corresponding required input (frequency band, polarization).
- The detailed position of the individual connector will vary by the antenna manufacturer design. Minimum generic information to be provided is the side where the connectors are located in (top, back, bottom).

Specification Definition

- The same reference axis used to calculate the antenna’s mechanical dimensions shall be used to define the “top”, “back” and “bottom” of the antenna.
- For the purpose of this whitepaper, the only possibilities are “top”, “back” and “bottom”.

Specification Example

- Port 5 (horizontal polarization) is a “7-16 male” port that is located at the bottom of the antenna.

XML - Tag Example

```
<port name="5" polarization="H" location="bottom" connector_type="7-16 male"/>
```

Relevance

- Knowledge of the connector position is required for proper antenna operation. It also supports upfront planning of antenna system cabling for the individual installation site.

5.8 Survival Wind Speed

Parameter Definition

- The survival wind speed defines the maximum wind velocity the BSA can withstand without suffering permanent damage. It shall also survive without being mechanically or electrically affected due to wind forces in any way that would require service maintenance at the site.

Specification Definition

- Nominal value in kilometers per hour.

Specification Example

- The antenna can withstand 200 km/h without being damaged.

XML - Tag Example

```
<survival_wind_speed value="200"/>
```

Relevance

- The survival wind speed marks one limiting factor in the network viability against the influence of the wind. For the operators it is relevant that the product as well as the existing network installation remains functional, in order to avoid maintenance. In some countries there are legal requirements to ensure communication systems availability after natural catastrophes such as hurricanes or tornados.

5.9 Radome Material

Parameter Definition

- The radome material provides high level information about the material the antenna radome is made of. This information will not be detailed to certain composition variants and/or supplier references.

Specification Definition

- The material of which the radome is made of.

Specification Example

- Example: antenna radome is made from a PVC material.

XML - Tag Example

```
<radome_material value="PVC"/>
```

Relevance

- The material of the radome contributes to the overall antenna environmental compliance.

5.10 Radome Color

Parameter Definition

- The radome color is a simple statement about the color of the radome. This is commonly related to the material used to build it.
- Color options for BSA radomes are uncommon.

Specification Definition

- RAL color code.

Specification Example

- The radome's color is RAL7005.

XML - Tag Example

```
<radome_color value="RAL7005"/>
```

Relevance

- The radome color might be of interest to minimize obtrusiveness of an antenna installation.

5.11 Product Environmental Compliance

Parameter Definition

- Overall the environmental compliance is the combination of all individual environmental compliance statements declared for the product (see Chapter 6).
- Recyclability of the product falls also under the environmental compliance term.
- A variety of different standards with different contents and focuses exist across the globe.
- Compliance requirements for the product depend on the country where the antenna is to be shipped to or installed in. The product shall fulfill these requirements.
- The necessity to state the environmental compliance in the datasheet depends on the individual needs. Nevertheless it can be done for marketing purposes.
- The compliance information shall be provided as part of the product documentation and/or shipping papers in order to ensure that the import/export of the product from/into countries is possible.
- Specific product marking requirements (if any) are defined by the corresponding environmental standard.

Specification Definition

- The environmental standard name and optionally a compliance to a particular class.

Specification Example

- RoHS, Reach, WEEE, ETSI EN 300019-1-2 class 4.1 E, etc.

XML - Tag Example

```
<product_environmental_compliance_general standard="RoHS"  
compliance="full_compliant"/>  
  
<product_environmental_compliance_transportation standard="ETSI EN 300019-1-2"  
compliance="Class 2.3"/>  
  
<product_environmental_compliance_environmental_conditions standard="ETSI EN  
300019-1-4" compliance="Class 4.1 E "/>  
  
<product_environmental_compliance_storage standard="ETSI EN300019-1-1"  
compliance="Class 1.2"/>  
  
<product_environmental_compliance_packed_storage standard="ETS EN300019-1-1"  
compliance="Class 1.1"/>
```

Note: it is possible to insert more product environmental compliances by adding more XML tags. Should this be necessary, the following tag format shall be used:

```
<product_environmental_compliance_xxx standard="yyy" compliance="zzz"/>
```

Where “xxx”, “yyy” and “zzz” can be customized by the antenna producer.

Relevance

- The compliance to individual environmental standards might be required by law, can be an industry wide accepted “best practice” or might be requested by the individual customer.

5.12 Mechanical Distance between Antenna Mounting Points

Parameter Definition

- The mechanical distance between antenna mounting points defines the vertical distance between the fixation points of the antenna to its mounting hardware.

Specification Definition

- Nominal values in millimeters.

Specification Example

- Example: S1 = 1274 mm (see figure 53)

XML - Tag Example

```
<mechanical_distance_between_mounting_points_antenna value="1274"/>
```

Relevance

- This value is of interest for installation site planning to ensure the corresponding tower provides sufficient clearance, and for the installation teams in order to mount the antenna correctly.

5.13 Mechanical Distance between Pole Mounting Points

Parameter Definition

- The mechanical distance between pole mounting points defines the vertical distance between the mounting brackets of an antenna at the pole.
- This might be in line with the mechanical distance between antenna mounting points.

Specification Definition

- Nominal values in millimeters.

Specification Example

- Example: S2 = 1019 mm (see figure 53)

XML - Tag Example

- Antennas may have different options for their mounting kits, therefore the value associated to this parameter may change consequently. Vendors should therefore consider as a good practice to state all the possibilities under the `vendor_comments` tag (see Section 10.1.8).

Relevance

- This value is of interest for the installation site planning to ensure that the corresponding tower provides sufficient clearance, and for the installation teams in order to be able to mount the antenna correctly.

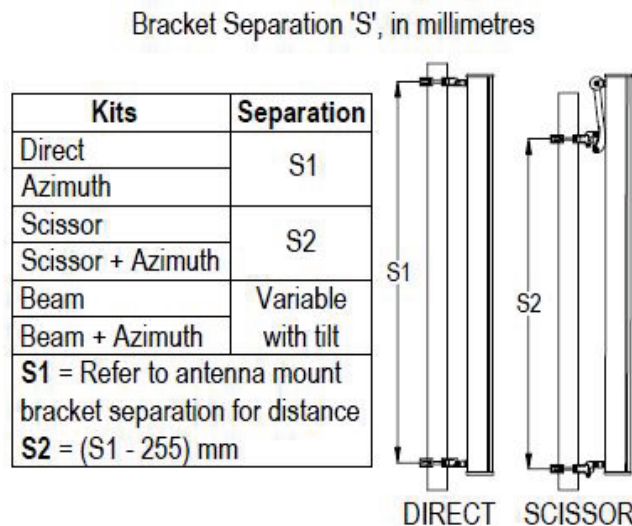

Figure 53—Potential differences between “distance between antenna mounting points” and “distance between pole mounting points”.

5.14 Lightning Protection

Parameter Definition:

- It is a simple statement on the equipment whether the equipment supplier considers the equipment lightning protected.

Specification Definition:

- Protected or not protected.

Specification Example

- The manufacturer considers the equipment lightning protected.

XML - Tag Example

```
<lightning_protection value="yes"/>
```

Relevance

- According to good practice and relevant national standards, it is always assumed that an antenna supporting structure or pole is grounded and/or connected to a lightning protection system.

6 Remote Electrical Tilt System

A remote electrical tilt is a device capable of adjusting an antenna's electrical downtilt by receiving appropriate commands from a remote user or system. RET units consist of two elements: controller and actuator. A controller contains the logical unit that receives and interprets the commands, while the actuator is a transducer that can alter mechanically or electrically the phase of the antenna's feed signal in order to achieve a certain degree of electrical downtilt. Since controllers can be positioned relatively far away from the antenna, from now on only the part immediately attached to or integrated in the antenna will be referred to as RET. RETs are categorized in fact in three branches: internal, external and partially external. The first ones are embedded into antennas, while the second ones are typically but not exclusively attached to the bottom of antennas. The third ones are a particular subset of the external RETs, and are characterized by being partially inserted into the antenna, and partially protruding outside it.

General RET requirements are specified in the framework of the Antenna Interface Standards Group (AISG) where specifications for the control interface of antenna devices are defined. RET systems have to operate in accordance with the AISG standards and with all the relevant part of the 3GPP (Third Generation Partnership Project) specifications.

In this paper the RET parameters will always be, when not specifically otherwise written, intended as required.

The format used for the RET parameters will be the same used for electrical specifications and mechanical specifications.

6.1 Actuator Size

Parameter Definition

- The RET stand-alone dimensions.
- The RET installed dimensions.
- The stand-alone and installed dimensions are defined along the same three axis of a Cartesian coordinate system defining the height (H), the width (W) and the depth (D) of the product (see figure 54).
- Installed dimensions define the section of the RET protruding beyond the RET installation reference plane (see figure 55 and Section 5.1).

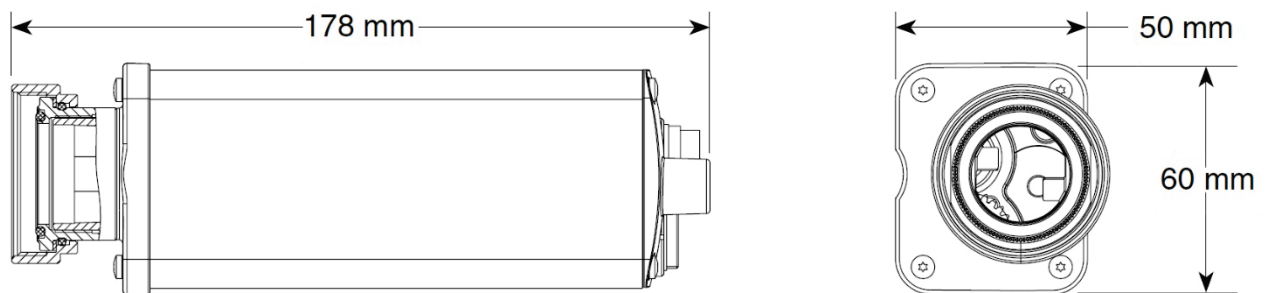

Figure 54—Example of an external RET.

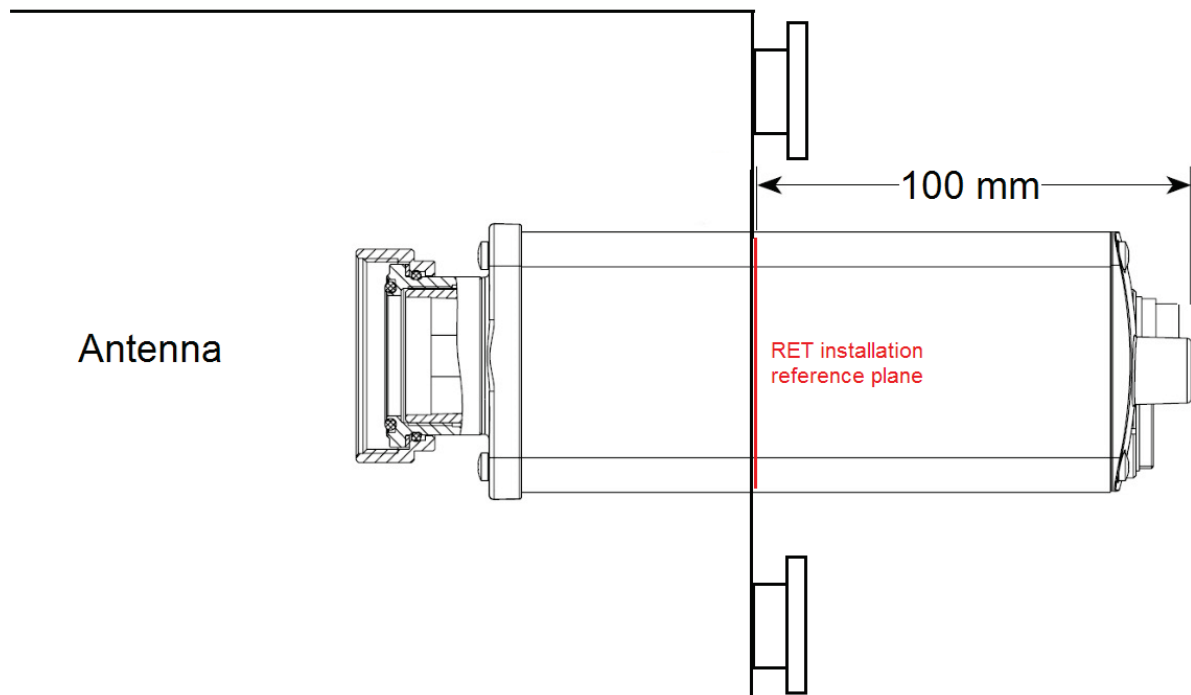

Figure 55—Example of the height dimension of an installed partially external RET. Its protrusion out of the antenna lies along the antenna height plane (H).

Specification Definition

- The RET dimensions are its nominal values specified in millimeters.
- Assuming the RET is oriented similar to antenna alignment on the tower prior any antenna tilting:
 - Height is measured along the vertical direction of the RET (typically this is also the largest dimension).
 - Width is measured along the horizontal direction of the RET.
 - Depth is measured perpendicular to the plane spanned by vertical and horizontal direction.
- For partially external RET actuators H x W x D refers to the protrusion dimensions beyond the antenna RET installation reference plane.
- The RET installation reference plane is described by the H, W, or D dimension, but is actually the plane normal (or most normal) to it.
- Should an installed RET not protrude beyond the antenna RET installation reference plane, its dimensions H x W x D shall always be equal to 0mm x 0mm x 0mm. In this case the RET is integrated.
- External RET are those whose installed dimensions are equal to their stand-alone dimensions.
- RETs that are not external, nor integrated, are partially external ones.
- Should the same partially external RET exhibit different protrusions for different antenna interfaces, the stated RET dimensions shall be the ones relative to the protrusion, which occupies the most space beyond the RET installation reference plane.

Specification Example

- Stand-alone dimensions:
 - External RET - H x W x D: 178mm x 60mm x 50mm (see figure 54).
 - Partially external RET - H x W x D: 178mm x 60mm x 50mm (see figure 54 and 55).
 - Integrated RET - H x W x D: 160mm x 50mm x 30mm.
- Installed dimensions:
 - External RET - H x W x D: 178mm x 60mm x 50mm (see figure 54).
 - Partially external RET - H x W x D: 100mm x 60mm x 50mm (see figure 54 and 55).
 - Integrated RET - H x W x D: 0mm x 0mm x 0mm.

XML - Tag Example

- Partially integrated RET:

```
<standalone_dimensions height="178" width="60" depth="50"/>
```

```
<installed_dimensions height="100" width="60" depth="50" reference="H"/>
```

Relevance

- The RET actuator dimensions are relevant to plan detailed antenna installations regarding required space, required fixation points and visual impact.
- The RET dimensions also impact the wind load at a rated wind speed.

6.2 Working Temperature Range

Parameter Definition

- The temperature range in which the RET can operate properly, without suffering permanent damage. It shall also survive without being mechanically or electrically affected due to temperature in any way that would require service maintenance at the site.

Specification Definition

- Nominal values in Celsius degrees.
- Minimum and Maximum operating temperatures.

Specification Example

- Minimum temperature = -20°C; Maximum temperature = +60°C.

XML - Tag Example

```
<working_temperature_range max="60" min="-20"/>
```

Relevance

- The RET working temperature range is relevant to evaluate the overall operational working temperature of the RET system and ensure its correct operation.

6.3 Power Consumption

Parameter Definition

- The RET's consumption of energy.

Specification Definition

- Nominal values in Watts.
- Values specified for low- and high-power modes.
- Definitions of low- and high-power modes according to the relevant 3GPP specification.

Specification Example

- Low power consumption = 0.5W; High power consumption = 5W.

XML - Tag Example

```
<power_consumption high_power="5.0" low_power="0.5"/>
```

Relevance

- The RET power consumption is relevant to estimate a correct overall energy economy.

6.4 Loss of Position on Power Failure

Parameter Definition

- This parameter defines, in accordance to the relevant part of AISG standard, whether the RET loses its position in the event of a power failure during the movement of its motor.

Specification Definition

- True / False.

Specification Example

- True

XML - Tag Example

```
<lose_position_on_power_failure value="true"/>
```

Relevance

- In case the position is lost, it is necessary to set the electrical tilt of the RET again whenever the power is re-established.

6.5 Compatible Standards

Parameter Definition

- List of standards which the RET is fully compliant to.

Specification Definition

- Standards names can be written in multiple fashions (e.g.: upper or lower case letters, version specification beginning with "v" or nothing at all). It is the task of the datasheet's provider to write the name and version of the standards understandably, while it is the end-user's task to correctly interpret them.
- The character sequence of: space, semicolon and space shall only be used to separate the string of a standard from the following one.

Specification Example

- RET is compliant with AISG v1.1 and v2.0.

XML - Tag Example

```
<compatible_standards value="aisg v1.1 ; AISG2"/>
```

Relevance

- Compliance to standards is relevant for RET installation and controlling.

6.6 Compatible Proprietary Protocols

Parameter Definition

- List of proprietary protocols which the RET is fully compliant to.

Specification Definition

- Protocols names can be written in multiple fashions (e.g.: upper or lower case letters, version specification beginning with “v” or nothing at all). It is the task of the datasheet’s provider to write the name and version of the protocols understandably, while it is the end-user’s task to correctly interpret them.
- The character sequence of: space, semicolon and space shall only be used to separate the string of a protocol from the following one.

Specification Example

- RET is compliant with the proprietary protocols of the companies A and B.

XML - Tag Example

```
<compatible_protocols value="a proprietary ; B_company"/>
```

Relevance

- Important to handle the refarming of the sites where the old RET systems are maintained with proprietary protocols.

6.7 Configuration Management

Parameter Definition

- This parameter defines how the RET configuration is managed. It is applicable to all RETs, internal and external.
- The applicable values are specific to internal or external RETs.
- It is possible that some internal RETs might require field configuration, while some internal RETs might be fixed (not field replaceable).
- RETs may be delivered with configuration already loaded (pre-configured). If “not pre-configured” is noted, then configuration is required (loading the configuration file) before the RET can be operational.
- Pre-configured means the RET comes from factory equipped with the appropriate configuration file, no configuration process is required.
- Automatically configuring means the RET will detect the antenna to which it will be connected and automatically configure itself to work with that antenna, no configuration process is required.

Specification Definition

- Only the following values are accepted:
 - “External RET, not pre-configured”
 - “External RET, pre-configured”
 - “External RET, automatically configured”
 - “Integrated RET, not pre-configured”
 - “Integrated RET, pre-configured”

- “Integrated RET, automatically configured”

Specification Example

- RET is external and not pre-configured.

XML - Tag Example

```
<configuration_management value="external ret, not pre-configured"/>
```

Relevance

- This parameter is relevant to the operators involved in setting and configuring the RET to a specific antenna mode for RET position movement.

6.8 Antenna Configuration File Availability

Parameter Definition

- This parameter defines whether the configuration file for a specific antenna is available or not. For specific antennas the manufacturer provides (when available) the antenna configuration file. This typically happens during the delivery process or during operation.

Specification Definition

- True / False.

Specification Example

- False.

XML - Tag Example

```
<antenna_configuration_file_available value="false"/>
```

Relevance

- This parameter is only relevant for a specific antenna model. As an example, in case of need to substitute the antenna, the manufacturer should be able to provide the relevant configuration file.

6.9 Antenna Configuration File Upgradability

Parameter Definition

- This parameter defines whether the configuration file for a specific antenna is upgradable and in that case specifies how.
- This parameter typically applies to external RETs, and RETs that require configuration in the field.

Specification Definition

- Only the following values are accepted:

- “Yes, by base station only”
- “Yes, by proprietary portable controller only”
- “Yes, by base station and proprietary portable controller”
- “No”

Specification Example

- RET configuration file can be updated both from the base station and from the proprietary portable controller.

XML - Tag Example

```
<antenna_configuration_file_upgradable value="yes, by base station and  
proprietary portable controller"/>
```

Relevance

- RETs that can be installed and/or configured for an antenna in the field might require configuration per one of these methods.

6.10 Software Upgradability

Parameter Definition

- This parameter defines whether the RET operative system software is upgradable and in that case specifies how.

Specification Definition

- Only the following values are accepted:
 - “Yes, by base station only”
 - “Yes, by proprietary portable controller only”
 - “Yes, by base station and proprietary portable controller”
 - “No”

Specification Example

- RET software cannot be upgraded.

XML - Tag Example

```
<software_upgradable value="no"/>
```

Relevance

- For a RET that allows the software to be upgraded in the field, this defines the available methods for upgrading the software.

6.11 Replaceability in Field

Parameter Definition

- This parameter defines whether the RET is replaceable (can be mounted/dismounted) in the same environment where the antenna is operating. In that case specifies if it is possible only by removing the antenna from its support, or if this activity may take place without this operation.

Specification Definition

- Only the following values are accepted:
 - “Yes, without removing antenna”
 - “Yes, only removing antenna”
 - “No”

Specification Example

- RET can be replaced in the field, but in order to be able to do it, the antenna to be removed from its support.

XML - Tag Example

```
<field_replacement_allowed value="yes, only removing antenna"/>
```

Relevance

- This parameter is relevant to the operators involved in maintenance and installation of RETs.

6.12 Visual Indicator Available on Tilt Change

Parameter Definition

- This parameter defines whether operators within a reasonable distance to the RET are able to be visually notified when a change of downtilt takes place.
- The beginning and the end of the procedure shall be recognizable.
- If the RET is not integrated, the visual indicator shall be visible by looking at its external surface.
- If the RET is integrated, the visual indicator shall be visible by looking at the external surface of the RET or of the antenna.
- For some antenna models, the visual indicator may be part of the antenna, and thus associated with the antenna.

Specification Definition

- True / False.

Specification Example

- False.

XML - Tag Example

```
<visual_indicator_available_on_tilt_change value="false"/>
```

Relevance

- This parameter is relevant to the operators involved in maintenance and testing of RETs.

6.13 Daisy Chain Available

Parameter Definition

- This parameter defines whether it is possible to connect the RET to another one via daisy chain.

Specification Definition

- True / False.

Specification Example

- False.

XML - Tag Example

```
<daisy_chain_available value="false"/>
```

Relevance

- This parameter is relevant to the operators involved in the installation of RETs and to those responsible for the correct functioning of a whole cell.

7 Environmental Standards

7.1 Base Station Antenna Environmental Criteria

The operating environment of base station antennas is classified as remote, stationary, outdoor, uncontrolled and not weather-protected. The electromagnetic environment includes close proximity to intentionally radiating devices and installation on structures prone to lightning strikes. The systems are expected to operate in this environment for an extended period of time. This, together with storage, transport and installation conditions, defines the “mission profile” for antennas and other tower top systems – a key factor needed to their determine reliability.

ETSI defined climatic classifications to describe the operating environment for tower top systems. Considering that installation environments vary, an antenna cannot fit in only one group, because those depend highly on the installation area. A summary of these classifications is given in the following table:

- Class 4.1 represents a nominal uncontrolled outdoor environment.
- Class 4.1E extends temperature and humidity ranges to the average minimum and maximum temperatures in the 5 European climatic zones.
- Classes 4.2L and 4.2H represent more extreme climates addressed by ETSI, but these are also further extended in regions outside of Europe.

For example, high temperature operation at +70°C is a common requirement for base station antennas.

Environmental Parameter	Classes				Unit
	4.1	4.1E	4.2L	4.3H	
Minimum air temperature	-33	-45	-65	-20	°C
Maximum air temperature	40	45	35	55	°C
Minimum relative humidity	15	8	20	4	%RH
Maximum relative humidity	100	100	100	100	%RH
Minimum absolute humidity	0.26	0.03	0.003	0.09	g/m3
Maximum absolute humidity	25	30	22	36	g/m3
Rain intensity	6	15	15	15	mm/min
Maximum temperature change rate	0.5	0.5	0.5	0.5	°C/min
Minimum air pressure	70	70	70	70	kPa
Maximum air pressure	106	106	106	106	kPa
Solar radiation	1120	1120	1120	1120	W/m2
Maximum wind speed	50	50	50	50	m/s

Table 11—ETSI 300 019-1-4 stationary, non-weather protected environmental classes.

The standard BSA product complies to the ETSI EN 300019-1-4 standard for environmental conditions: Class 4.1 E but, as already mentioned, customer requirements and application scenarios might call for more rigid environmental class compliance such as 4.2L or 4.2H. The specific design changes and material selections required for that compliance is out of the scope of this whitepaper.

Standard BSAs comply also with:

- ETSI EN 300019-1-1 for storage: Class 1.2 (see Section 6.3.1).
- ETSI EN 300019-1-2 for transportation: Class 2.3.

Note: Should the standards be updated, or should better standards be available, the recommendation is to use those instead.

7.2 Environmental Test Approach

The generic test approach for qualifying BSA products is similar to other technical qualification best practice rules. Overall target is to demonstrate compliance to the applicable standard and one of its environmental classes.

This qualification requires for each of the environmental parameters (see table above):

- A defined test setup: this serves as instruction to set the test up in a defined reproducible way using certified test equipment. It consists typically of a plan or block diagram identifying the components and devices of the whole setup, their serial numbers and a wiring diagram. The start settings and/or calibration procedure of the above mentioned equipment shall also be included.
- The definition of standard atmospheric conditions (see IEC 60068) in which the tests take place (even if during test the specimen might be subject to strongly deviating conditions). These are defined as ranges to enable testing in environments not completely climatic controlled.
- A uniform and reproducible method of environmental test: the procedures of IEC 60068 cover the different environmental parameters applicable to BSA.
- Trained test operator(s) proficient in the usage of test equipment and measurement devices.
- A defined number of test specimens. This is rarely prescribed by IEC 60068, but the testing team should consider this in relation to the test reproducibility: the test might fail or pass by cause of different devices production techniques, materials, number of suppliers, etc. In case the test effects

have some statistic behavior, the number of test specimen should be selected accordingly (under consideration of test efforts in time and budget).

- A defined set of acceptance criteria. The test specimen shall comply to the defined acceptance criteria prior and after the test. These criteria are also to be observed and rated during the test itself. Available test equipment might limit the “during the test” assessment, so a practical but also documented approach on what is required and what can be done is necessary. The list of acceptance criteria differs by parameter: for environmental performance ones it typically includes functional tests, electrical measurements and visual inspection.
- A test documentation. This consists of the raw test data and protocols rating the actual measured values against the test criteria, the identification of the tested specimen (e.g.: by model number and serial number) and finally the test report. It documents the compliance of the tested devices prior the tests, specific test events, observations, consolidated data of the test itself and the device compliance to the acceptance criteria after the test was performed. The report is then concluded by an assessment of the test results, a compliance statement and a conclusion.

7.3 Environmental Test Methods

The following criteria are used to demonstrate that base station antennas can operate as needed (hence all the parameters given in the datasheet are valid) in the environments in which they will be typically set in operation. These tests alone cannot, though, determine an antenna’s reliability, which is the probability over time that it will continue to operate as needed in these environments. However, they can establish the initial reliability and indicate a measure of an antenna’s service life. The aforementioned criteria are based on publicly available and widely accepted test methods (generally on ETSI Class 4.1 for common performance needs under nominal conditions or Class 4.1E for extended use – 10 or more years – in harsher environments).

Comparing the standard ETS300019-2-4 with the IEC60068 it is clear that the characteristic severities of the ETS might deviate from the corresponding ones of the IEC. Due to this fact and because in general the definitions of the standards should be sanity-checked considering the BSA application, this whitepaper recommends test limits that may deviate from corresponding ETS and IEC recommendations.

7.3.1 Packaged Storage

While packaged, transported and stored, antennas shall tolerate non-temperature-controlled-weather-protected-environments without degradation (Baseline: ETS 300 019-1-1 Class 1.2; -25 to +55°C; 10% to 100% Relative Air Humidity). The conditions for water from sources other than rain are the limiting factor for the environmental class of packaged storage. The higher ETS 300 019-1-1 classes 1.3 and 1.3E include splashing water also from side or bottom directions, but since the antennas are packed in cardboard boxes that normally draw water, get wet and soften up until they rip apart, the packaged storage class shall be limited to the class 1.2.

7.3.2 Cold Temperature Survival

Antennas shall operate within their specifications after exposure to cold air temperature following IEC 60068-2-1 test methods (Baseline: ETS 300 019-1-4 Class 4.1; 16 hours at -33°C / Extended: ETS 300 019-1-4 Class 4.1E – further extended to 16 hours at -40°C). Due to test equipment limitations it is not possible to demonstrate the proper antenna operation and/or the behavior of all antenna parameters during the cold temperature survival test. The operation of the device is verified prior and following to the test.

7.3.3 Hot Temperature Survival

Antennas shall operate within their specifications after exposure to hot air temperature following IEC 60068-2-2 test methods (Baseline: ETS 300 019-1-4 Class 4.1; 16 hours at +40/55°C / Extended: ETS 300 019-1-4 Class 4.1E – further extended to 16 hours at +60°C). Due to test equipment limitations it is not possible to demonstrate the proper antenna operation and/or the behavior of all antenna parameters during the cold temperature survival test. The operation of the device is verified prior and following to the test.

7.3.4 Temperature Cycling

Antennas shall operate within their specifications after exposure to temperature cycling following IEC 60068-2-14 test methods (Baseline: ETS 300 019-2-4 Class T4.1; 2 cycles with T1 = 3h and 0.5 °C/min from -10°C to +40°C / Extended: ETS 300 019-2-4 Class T4.1E; 2 cycles with T1 = 3h and 0.5 °C/min from -10°C to +45°C).

The characteristic severity of the lower temperature of ETS300019-2-4 strongly differs from the one defined in the cycle testing of IEC 60068-2-14, but considered that technically the risk for failures increases in the lower end of the temperature range, and having acknowledged the testing capabilities, this whitepaper recommends, as a proper compromise between the ETSI and the IEC requirements, applying 5 cycles from -25 to +45 °C allowing temperature change rates of 1 °C/min.

7.3.5 Vibration – Sinusoidal

Antennas shall operate within their specifications after (non-operating) exposure to sinusoidal vibration following IEC 60068-2-6 test methods (Baseline: Five 2-200 Hz sweeps in each X, Y and Z axis, limited to 0.5g / Extended: Five 2-200 Hz sweeps in each X, Y and Z axis, limited to 1.0g). This whitepaper recommends 5 Hz as minimum frequency due to test equipment limitations.

7.3.6 Humidity Exposure

Antennas shall operate within their specifications after (non-operating) exposure to humidity exposure following the IEC 60068-2-30 test methods (Baseline: 2 cycles between 25 and 40°C in 24 hours at 90-98% relative humidity / Extended: 2 cycles at 30°C in 24 hours at 90-98% relative humidity) or their equivalent.

The joint experience is that no failures have been ever observed for these tests. Thus, it is considered to be a low risk parameter that could be verified with a shorter standard test of 2 cycles/8 hours. In the case where a new design with major design changes and/or different materials is tested, the experts teams shall instead apply the more rigid 6 cycles/24 hours testing.

7.3.7 Rain

Antennas shall operate within their specifications after (non-operating) exposure to simulated rain following the IEC 60068-2-18 test methods (Baseline: ETS 300 019-1-4 Class 4.1: 6 mm/minute for 30 min / Extended: ETS 300 019-1-4 Class 4.1E: 15 mm/minute for 30 min).

Requirements of 10 mm/min for 30 minutes are in this whitepaper considered an acceptable compromise between the ETS and IEC characteristic severities.

7.3.8 Water Ingress

Antennas electronics and RF path interconnections potentially exposed to water shall be protected against splashed, sprayed or windblown ingress to a rating of IPX6 as defined by IEC 60529 “degrees of protection provided by enclosures (IP Code)”.

This whitepaper recommends the value not to be stated in the technical customer documentation and datasheets, because only very rarely a customer inquires on this. It is seldom tested and the applicable class might be directly limited by design features (e.g.: rain drop holes).

7.3.9 Dust and Sand Ingress

Antenna components potentially harmed from dust or sand exposure shall be protected from their ingress to a rating of IP5X as defined by IEC 60529 “degrees of protection provided by enclosures (IP Code)” (Baseline: an IP5X dust ingress rating may be assumed without testing based on demonstration of an IPX6 water ingress rating / Extended: IEC 60068-2-68 Test Lc1 or the equivalent).

Overall, this is not considered to be a problem. It is extremely rarely tested, and if inquired, the figure might be deducted from the water Ingress test figure. This whitepaper recommends the value not to be stated in the technical customer documentation and datasheets.

7.3.10 Survival Wind Speed

Antennas shall survive exposure to forces simulating the effects of strong winds according to the definition in Section 5.8. It is calculated using methods consistent with Eurocode 1 “Actions on structures” – Part 1-4 “General actions” – “Wind actions” (EN 1991-1-4) and/or EIA/TIA 222-G (Baseline: 50 meters/sec 180 km/h or 112 mph / Extended: 50 meters/sec 180 km/h or 112 mph). The detailed reference to be used might vary by country and has to be checked accordingly.

The maximum wind velocities cited in ETS 3000019 are not considered to be sufficient for BSA applications. Consequently and in line with the customer requirements a standard survival wind speed of 200 km/h is defined. For higher windload designs typically 240 km/h is realized although individual customer tailored design solutions might be required. It is acceptable to demonstrate compliance to this survival wind speed by:

- Dynamic testing.
- Static testing.
- FEM modeling & simulation.
- Similarity to existing verified products.
- Analytics applying best structural engineering practices.

This whitepaper recommends: 55.6 meter/sec; 200 km/h (124 mph) for standard duty antennas, 66.6 meters/sec 240 km/h (150 mph) for heavy duty antennas.

7.3.11 UV/Weather Exposure

Antenna materials shall not degrade significantly after simulated solar exposure following the IEC 60068-2-18 test methods or their equivalent. The IEC defines three different methods with two cyclic (cycle of light and dark) and one continuous radiation exposure. The cyclic tests are considered to be more aggressive, especially the procedure B that has 20 hours light and only 4 hours dark time (Baseline: 20 hours on / 4 hours off at 55°C for 56 cycles/56 days = 1344 hours).

In order to save time, shortening the test duration was discussed. Experience is that test duration of at least 1000 hours shows the material failures and that the test samples have to be visually inspected. Moreover, some mechanical tests (tensile and/or bending) have to be performed to ensure the materials keep their properties and do not get brittle. The standards define detailed lists of light sources qualified for the test with resulting impact on test conditions (typically the wavelength of the UV is applied). Any light source compatible with the above mentioned cycling procedure B is acceptable.

Crack, chalking or permanent dimensional change might appear in any intermediate test or final inspection. The individual material changes that might be tolerated depend on the material and where it is used: this is to be risk assessed by the mechanical designer on a case by case basis; therefore no generic applicable guidance can be provided in this whitepaper. As an example, these material specific limits could be defined considering following behavior as a failure of the material:

- Mean tensile strength change > 10%
- Mean elastic modulus change > 30%
- Mean elongation change > 30%
- Mean impact strength change > 30%

Remark: Significant color changes completely changing the visual aspect of the antenna could become an issue for customer acceptance even if they would not negatively impact the environmental reliability of the antenna.

7.3.12 Corrosion Resistance

Antenna materials and surface finishes shall be corrosion resistant for the intended service lifetime. The system, or its components and materials, shall be tested for corrosion resistance following the IEC 60068-2-11, test Ka method (a.k.a. B117) using a salt fog (mist) from a neutral, 5% weight sodium chloride solution for 28 days = 720 hours (Standard Baseline: 10 days = 240 hours / Extended: "Procedure B" with 20 hours on / 4 hours off at 40°C for 28 days = 672 hours).

Functional tests shall be done prior to and after the corrosion exposure. The visual acceptance criteria are many and require some definition. While it is jointly agreed that after 28 days of salt spray testing there are always some 'salt' remains on the device (which is acceptable), corrosion starting at metal parts is not acceptable.

Due to limitations of test equipment it is not feasible to test complete antenna products in all cases. Suitable test samples are typically selected to demonstrate the viability versus salt corrosion of the antenna including all connectors, sealings, materials, joints and moving parts. This whitepaper recommends the test duration defined in IEC 60068-2-11 ranges from 16 hours to 672 hours = 28 days, but individual customer inquiries asking for even longer test durations might occur.

Acceptance criteria (visual inspection shall be done before and after test):

- Excessive corrosion in critical areas.
- Salt deposits in electrical critical areas.
- Corrosion of insulating materials and metals.
- Clogging or binding of movable parts.

After completing the test, the exposed materials may be washed with warm water and lightly brushed to remove the salt deposits and expose the base material under the salt.

The following are indications of material failure:

- The base material has been attacked by the salt deposits.
- In the case of plating, bubbling, lifting or the plating has been eaten through.
- For assemblies with working mechanical pieces, failures of thread, seals, etc.
- Leakages.
- Illegibility of marking and nameplate.

Moreover, electrical measurements have to be done before and after test (if applicable) to assess:

- VSWR.
- Isolation.
- Intermodulation.

7.3.13 Shock & Bump

An antenna shall survive shocks and/or bumps without suffering any permanent damage that can alter its electrical and/or mechanical features, compromising its service efficiency. Visual and operational checks are to be done prior to and after the shock & bump trial in order to verify whether the antenna has maintained its characteristics. The test method is indicated by IEC 60068-2-27 “Test Eb: Bump” (Baseline: antenna without packaging, half-sine bumps from 6 directions, 100 bumps in each direction).

This whitepaper recommends applying, irrespective of the product weight, the test specifications below:

Input Acceleration	Duration
50 m/s ²	11 ms

7.3.14 Free Fall (Packaged Product)

An antenna shall survive free falls without suffering any permanent damage that can alter its electrical and/or mechanical features, compromising its service efficiency. Visual and operational checks are to be done prior to and after the free fall trial in order to verify whether the antenna has maintained its characteristics. The test method is indicated by IEC 60068-2-31 (Baseline: packaged antenna, 1 fall per face or 2 falls, altitude specified in the table below).

Mass [kg]	Free fall test height [m]	
	Class T 2.2	Class T 2.3
< 10	0.8	1.0
< 20	0.6	0.8
< 30	0.5	0.6
< 40	0.4	0.5
< 50	0.3	0.4
< 100	0.2	0.3
> 100	0.1	0.1

Table 12—Free fall test heights.

This whitepaper recommends this either to be tested, or to declare the compliance referring to existing test results of products with similar packaging design. The test shall also be only applied for the 6 flat sides of the package (no corner drop test is applied).

7.3.15 Broadband Random Vibration

An antenna shall survive random vibration within a broad spectrum without suffering any permanent damage that can alter its electrical and/or mechanical features, compromising its service efficiency. Visual and operational checks are to be done prior to and after the vibration trial in order to verify whether the antenna has maintained its characteristics. The test method is indicated by IEC 60068-2-64 “Test Fh: Vibration broadband”.

This whitepaper recommends the tested frequency spectrum for broadband random vibration to be aligned with the one applied for the sinusoidal testing (see Section 7.3.5).

7.3.16 Steady State Humidity

Antenna materials and surface finishes shall be humidity resistant for the intended service lifetime. The system, or its components and materials, shall be tested for steady state humidity following the test method designated by IEC 60068-2-56 “Test Cab : Damp Heat, Steady state” (Baseline: 93% relative humidity, with a temperature of $+40^{\circ}\text{C} \pm 2^{\circ}\text{C}$ and a duration of 21 days = 504 hours).

The steady state humidity test according IEC 60068-56 allows different combinations of temperature and relative humidity and test durations in a range from 12 hours to 1344 hours = 56 days. The selected parameters above define a very stringent (highest temperature combined with highest relative humidity, second longest test duration) test condition, which is recommended by this whitepaper too.

8 Reliability Standards

Reliability is the probability that a product or service will perform as needed for a specified time and under specified operating conditions. It deals with the knowledge of the physics of failure and with the design to reduce it throughout the product’s service life or, for complex systems such as antennas, to make them tolerant to failures when they do happen. Acceptance and qualification tests address initial quality by showing that no failures occur under certain operating and environmental conditions. While these conditions may include “reliability demonstrations” (such as corrosion tests run for a fixed time), these tests cannot determine a product’s reliability.

By contrast, reliability tests are meant to actually cause failures, usually by “accelerating product aging”, so that realistic failures happen quickly. These tests are designed to measure failure rates (or MTBF values) and operating lifetimes. While there are many references for general reliability test methods (the IEC 60605 family of standards is one example), in practice most reliability tests and predictions are customized around product features and dominant failure mechanisms. As a result failure rates, MTBF values and lifetimes are always approximations under several assumptions, which shall be known and understood to properly compare predictions from different sources.

9 Additional Topics

9.1 Recommended Sub-bands and Associated Frequency List

From the operators point of view it is an ordinary procedure to require that antennas produced by vendors are measured by very specific frequencies of interest. This routine represents a huge problem in the economy of the vendors, which ultimately results in longer wait times and higher costs for everyone. It also denies an accurate comparison between antennas, since there is no assurance that similar antennas from different vendors are measured by the same frequency points. Thus it is critical that all the parties involved in the evaluation of antennas use an agreed upon set of frequencies for the calculation of antennas’ parameters.

Frequency bands for mobile telecommunications are highly standardized by organizations such as ETSI and 3GPP, hence here it will not be necessary to define them anew. This whitepaper will in fact refer to the latest operating bands table (at the time of this document's writing it was contained in section 4.5.1 of the 3GPP TS 37.104, v14.1.0, 2016-09), an adaptation of which will also be used in the following sections as an example, or an equivalent one (should the original table not be available or applicable anymore).

E-UTRA Operating Band	Uplink (UL) eNode B receive UE transmit		Downlink (DL) eNode B transmit UE receive		Duplex Mode
	F _{UL_low} – F _{UL_high}		F _{DL_low} – F _{DL_high}		
	1	1920 MHz	– 1980 MHz	2110 MHz	
2	1850 MHz	– 1910 MHz	1930 MHz	– 1990 MHz	FDD
3	1710 MHz	– 1785 MHz	1805 MHz	– 1880 MHz	FDD
4	1710 MHz	– 1755 MHz	2110 MHz	– 2155 MHz	FDD
5	824 MHz	– 849 MHz	869 MHz	– 894 MHz	FDD
6 ¹	830 MHz	– 840 MHz	875 MHz	– 885 MHz	FDD
7	2500 MHz	– 2570 MHz	2620 MHz	– 2690 MHz	FDD
8	880 MHz	– 915 MHz	925 MHz	– 960 MHz	FDD
9	1749.9 MHz	– 1784.9 MHz	1844.9 MHz	– 1879.9 MHz	FDD
10	1710 MHz	– 1770 MHz	2110 MHz	– 2170 MHz	FDD
11	1427.9 MHz	– 1447.9 MHz	1475.9 MHz	– 1495.9 MHz	FDD
12	699 MHz	– 716 MHz	729 MHz	– 746 MHz	FDD
13	777 MHz	– 787 MHz	746 MHz	– 756 MHz	FDD
14	788 MHz	– 798 MHz	758 MHz	– 768 MHz	FDD
15	Reserved		Reserved		FDD
16	Reserved		Reserved		FDD
17	704 MHz	– 716 MHz	734 MHz	– 746 MHz	FDD
18	815 MHz	– 830 MHz	860 MHz	– 875 MHz	FDD
19	830 MHz	– 845 MHz	875 MHz	– 890 MHz	FDD
20	832 MHz	– 862 MHz	791 MHz	– 821 MHz	FDD
21	1447.9 MHz	– 1462.9 MHz	1495.9 MHz	– 1510.9 MHz	FDD
22	3410 MHz	– 3490 MHz	3510 MHz	– 3590 MHz	FDD
23	2000 MHz	– 2020 MHz	2180 MHz	– 2200 MHz	FDD
24	1626.5 MHz	– 1660.5 MHz	1525 MHz	– 1559 MHz	FDD
25	1850 MHz	– 1915 MHz	1930 MHz	– 1995 MHz	FDD
26	814 MHz	– 849 MHz	859 MHz	– 894 MHz	FDD
27	807 MHz	– 824 MHz	852 MHz	– 869 MHz	FDD
28	703 MHz	– 748 MHz	758 MHz	– 803 MHz	FDD
29	NA		717 MHz	– 728 MHz	FDD ²
30	2305 MHz	– 2315 MHz	2350 MHz	– 2360 MHz	FDD
31	452.5 MHz	– 457.5 MHz	462.5 MHz	– 467.5 MHz	FDD
32	N/A		1452 MHz	– 1496 MHz	FDD ²
33	1900 MHz	– 1920 MHz	1900 MHz	– 1920 MHz	TDD
34	2010 MHz	– 2025 MHz	2010 MHz	– 2025 MHz	TDD
35	1850 MHz	– 1910 MHz	1850 MHz	– 1910 MHz	TDD
36	1930 MHz	– 1990 MHz	1930 MHz	– 1990 MHz	TDD
37	1910 MHz	– 1930 MHz	1910 MHz	– 1930 MHz	TDD
38	2570 MHz	– 2620 MHz	2570 MHz	– 2620 MHz	TDD
39	1880 MHz	– 1920 MHz	1880 MHz	– 1920 MHz	TDD
40	2300 MHz	– 2400 MHz	2300 MHz	– 2400 MHz	TDD
41	2496 MHz	– 2690 MHz	2496 MHz	– 2690 MHz	TDD
42	3400 MHz	– 3600 MHz	3400 MHz	– 3600 MHz	TDD
43	3600 MHz	– 3800 MHz	3600 MHz	– 3800 MHz	TDD
44	703 MHz	– 803 MHz	703 MHz	– 803 MHz	TDD
66	1710 MHz	– 1780 MHz	2110 MHz	– 2200 MHz	FDD ⁴
67	N/A		738 MHz	– 758 MHz	FDD ²

Note 1: Band 6 is not applicable.
 Note 2: Restricted to E-UTRA operation when carrier aggregation is configured. The downlink operating band is paired with the uplink operating band (external) of the carrier aggregation configuration that is supporting the configured Pcell.
 Note 3: FFS
 Note 4: The range 2180-2200 MHz of the DL operating band is restricted to E-UTRA operation when carrier aggregation is configured.
 Note 5: A UE that supports E-UTRA Band 66 shall receive in the entire DL operating band
 Note 6: A UE that supports E-UTRA Band 66 and CA operation in any CA band shall also comply with the minimum requirements specified for the DL CA configurations CA_66B, CA_66C and CA_66A-66A.
 Note 7: A UE that complies with the E-UTRA Band 66 minimum requirements in this specification shall also comply with the E-UTRA Band 4 minimum requirements.

Table 13—E-UTRA operating bands (ETSI TS 136 521-1, v13.1.0, 2016-05)

Each frequency range (UL + DL) specified in a table like the one above corresponds to one of the antennas' sub-bands, and shall be described by a series of frequency samples that characterize the range itself, and identify, along with the electrical downtilt degrees and the polarizations, the "coordinates", where the electrical parameters' specifications shall be measured.

As an example, let an antenna's electrical downtilt range from zero to two degrees, two polarizations (+45° and -45°), and let the E-UTRA operating band 31 of previous table be the sub-band to be analyzed. The values constituting the dataset of the particular 452.5-467.5 MHz sub-band shall then be measured by:

- 455 MHz, 0° tilt, +45° polarization
- 465 MHz, 0° tilt, -45° polarization
- 455 MHz, 1° tilt, +45° polarization
- 465 MHz, 1° tilt, -45° polarization
- 455 MHz, 2° tilt, +45° polarization
- 465 MHz, 2° tilt, -45° polarization

Where 455 MHz and 465 MHz were chosen as characteristic frequency samples to describe the E-UTRA operating band 31 (the choice method will be elaborated in the following paragraphs).

It is critical to acknowledge that the spectrum "evolves" and that a frequency table is very unlikely to remain unchanged throughout the time. Considering that at the time of this document's writing there was no standard or technical guideline defining a method to measure antennas through the use of specific frequency samples for each sub-band, it is impossible here to refer to another source or recommend a list of fixed frequencies, without having to update it each time a new table is published. In order to keep this document's adaptability to all the frequency tables to come, a "frequency ranges choice algorithm" and a "frequency samples choice algorithm" have been developed to be here recommended.

The proposed algorithm is a dynamic (innovation-resistant) one, and it was built around constraints defined by the fact that it is either very expensive, time-consuming and equipment-dependent to measure broadband antennas with simpler techniques, or very inaccurate to do it. For example, using a fixed "frequency step" (e.g.: measuring a 1710-2690 MHz band every 10 MHz), could require either too many (98 in this case) frequency samples – this would mean using expensive equipment and waiting longer for a measurement to end –, or only a few (e.g.: 25 samples, which is a much more reasonable number, would require a sample every 39.2 MHz), with the risk of representing antennas with a single "weak" or "strong" pattern for a broad specific frequency neighborhood (antennas' patterns change already in 20 MHz, in this case a single frequency would be used to be representative of almost two times the width).

9.1.1 Frequency Ranges Choice Method

The first steps of this algorithm consist in:

- Finding the most recent frequency table (see previous section).
- Copying the UL range in the DL column when the DL is marked by "N/A" (see Table 13) and vice versa.
- Approximating the frequency ranges to the nearest unit of megahertz.
- Sorting the table "horizontally", by defining "lowest" and "highest" portion of sub-bands, regardless of UL or DL.

- Sorting the table “vertically” in ascending fashion, giving priority to the lower start-frequency and, in the case of match, to the narrower band (total broadness of lowest + highest portions), and finally to the order of appearance (band number) in the original frequency table.

With reference to Table 13, the following should be obtained as results here:

Sorted table				
Band number	Lowest portion		Highest portion	
	start	stop	start	stop
31	452 MHz	458 MHz	462 MHz	468 MHz
12	639 MHz	716 MHz	729 MHz	746 MHz
28	703 MHz	748 MHz	758 MHz	803 MHz
44	703 MHz	803 MHz	703 MHz	803 MHz
17	704 MHz	716 MHz	734 MHz	746 MHz
29	717 MHz	728 MHz	717 MHz	728 MHz
67	738 MHz	758 MHz	738 MHz	758 MHz
13	746 MHz	756 MHz	777 MHz	787 MHz
14	758 MHz	768 MHz	788 MHz	798 MHz
20	791 MHz	821 MHz	832 MHz	862 MHz
27	807 MHz	824 MHz	852 MHz	869 MHz
26	814 MHz	849 MHz	859 MHz	894 MHz
18	815 MHz	830 MHz	860 MHz	875 MHz
5	824 MHz	849 MHz	869 MHz	894 MHz
19	830 MHz	845 MHz	875 MHz	890 MHz
8	880 MHz	915 MHz	925 MHz	960 MHz
11	1428 MHz	1448 MHz	1476 MHz	1496 MHz
21	1448 MHz	1463 MHz	1496 MHz	1511 MHz
32	1452 MHz	1496 MHz	1452 MHz	1496 MHz
24	1525 MHz	1559 MHz	1626 MHz	1660 MHz
4	1710 MHz	1755 MHz	2110 MHz	2155 MHz
10	1710 MHz	1770 MHz	2110 MHz	2170 MHz
3	1710 MHz	1785 MHz	1805 MHz	1880 MHz
66	1710 MHz	1780 MHz	2110 MHz	2200 MHz
9	1750 MHz	1785 MHz	1845 MHz	1880 MHz
2	1850 MHz	1910 MHz	1930 MHz	1990 MHz
35	1850 MHz	1910 MHz	1850 MHz	1910 MHz
25	1850 MHz	1915 MHz	1930 MHz	1995 MHz
39	1880 MHz	1920 MHz	1880 MHz	1920 MHz
33	1900 MHz	1920 MHz	1900 MHz	1920 MHz
37	1910 MHz	1930 MHz	1910 MHz	1930 MHz
1	1920 MHz	1980 MHz	2110 MHz	2170 MHz
36	1930 MHz	1990 MHz	1930 MHz	1990 MHz
23	2000 MHz	2020 MHz	2180 MHz	2200 MHz
34	2010 MHz	2025 MHz	2010 MHz	2025 MHz
40	2300 MHz	2400 MHz	2300 MHz	2400 MHz
30	2305 MHz	2315 MHz	2350 MHz	2360 MHz
41	2496 MHz	2690 MHz	2496 MHz	2690 MHz
7	2500 MHz	2570 MHz	2620 MHz	2690 MHz
38	2570 MHz	2620 MHz	2570 MHz	2620 MHz
42	3400 MHz	3600 MHz	3400 MHz	3600 MHz
22	3410 MHz	3490 MHz	3510 MHz	3590 MHz
43	3600 MHz	3800 MHz	3600 MHz	3800 MHz

Table 14—Sorted frequency table.

At this point a deeper analysis of the table is necessary. Before selecting each sub-band's representative samples, it should be noticed that some of these sub-bands are *contained* in others and some *overlap* each other. In these cases, the method proposed in this whitepaper contemplates a **unification of the sub-bands** in accordance to the following set of rules:

- Each sub-band in the sorted table shall be compared with the immediately following one.
- Should the application of these rules result in a “merged” band, this one shall be immediately considered for the next comparison.
- If a band is completely contained in another one, the broader will represent them both and keep all its characteristics. Exceptions to this rule are sub-bands, which are only contained in another's band-gap (between the lowest and highest portions of the sub-band), and those whose total bandwidth is narrower than half the other's width.

Example: sub-band 44 and 17 are compared. The first one has no band gap, while the second one has a gap between 716 MHz and 734 MHz; the total bandwidth of sub-band 17 is 90 MHz, while band 44 is 100 MHz broad (sub-band 17 is $\geq 50\%$ of band 44's width). Sub-band 44 contains sub-band 17 totally and none of the exceptions are verified. A new sub-band called “17+44” will take place of the two merged ones and will extend from 703 MHz to 803 MHz. Per the second point, the sub-band 17+44 shall then be compared to sub-band 29.

- If at least the 70% of a sub-band is contained in another, a new one will represent them both. In this case its start frequency shall be the lowest amongst the two analyzed sub-bands, by analogy the stop frequency shall be the highest instead. If both the merged sub-bands contain a band-gap, the new sub-band will too contain a gap, which will split the sub-band in lowest and highest portion. This new gap shall be the “common gap”, that is the spectrum that does not contain any bit of any portion of any of the two analyzed sub-bands.

Example: Sub-Band 18 overlaps with sub-band 5. The overlapping ranges are 824-830 MHz in the lower portion and 869-875 MHz in the higher portion of the sub-bands. The total overlapping spectrum is 12 MHz, which is the 40% of the sub-band 18 and 13.3% of sub-band 5. In this case the sub-bands are not merged (none of them reaches 70%), but if they were, the common gap would have been 849-860 MHz and the new sub-band would have been the “18+5”, whose portions would have been 815-849 MHz and 860-894 MHz.

- Finally, if the total width of a sub-band is lower or equal than 30 MHz, and it has a difference from another sub-band of no more than 10 MHz between start frequencies and/or end frequencies of both the portions, the narrower sub-band shall be merged with the broader one. In this case, regardless of the overlapping percent, the procedure to follow is described in the previous point.
- These rules shall be applied over again, until no bands can be merged anymore.

After this process, the frequency table should look as follows:

Band number	Lowest portion		Highest portion		B-width Low	B-width High	Gap
	start	stop	start	stop			
31	452 MHz	458 MHz	462 MHz	468 MHz	6 MHz	6 MHz	4 MHz
12+28+44	639 MHz	803 MHz	639 MHz	803 MHz	104 MHz	104 MHz	0 MHz
17	704 MHz	716 MHz	734 MHz	746 MHz	12 MHz	12 MHz	18 MHz
29	717 MHz	728 MHz	717 MHz	728 MHz	11 MHz	11 MHz	0 MHz
67	738 MHz	758 MHz	738 MHz	758 MHz	20 MHz	20 MHz	0 MHz
13	746 MHz	756 MHz	777 MHz	787 MHz	10 MHz	10 MHz	21 MHz
14	758 MHz	768 MHz	788 MHz	798 MHz	10 MHz	10 MHz	20 MHz
20	791 MHz	821 MHz	832 MHz	862 MHz	30 MHz	30 MHz	11 MHz
27	807 MHz	824 MHz	852 MHz	869 MHz	17 MHz	17 MHz	28 MHz
26+18+5+19	814 MHz	849 MHz	859 MHz	894 MHz	35 MHz	35 MHz	10 MHz
8	880 MHz	915 MHz	925 MHz	960 MHz	35 MHz	35 MHz	10 MHz
11	1428 MHz	1448 MHz	1476 MHz	1496 MHz	20 MHz	20 MHz	28 MHz
21	1448 MHz	1463 MHz	1496 MHz	1511 MHz	15 MHz	15 MHz	33 MHz
32	1452 MHz	1496 MHz	1452 MHz	1496 MHz	44 MHz	44 MHz	0 MHz
24	1525 MHz	1559 MHz	1626 MHz	1660 MHz	34 MHz	34 MHz	67 MHz
4+10	1710 MHz	1770 MHz	2110 MHz	2170 MHz	60 MHz	60 MHz	340 MHz
3	1710 MHz	1785 MHz	1805 MHz	1880 MHz	75 MHz	75 MHz	20 MHz
66	1710 MHz	1780 MHz	2110 MHz	2200 MHz	70 MHz	90 MHz	330 MHz
9	1750 MHz	1785 MHz	1845 MHz	1880 MHz	35 MHz	35 MHz	60 MHz
2+35+25	1850 MHz	1995 MHz	1850 MHz	1995 MHz	145 MHz	145 MHz	0 MHz
39+33	1880 MHz	1920 MHz	1880 MHz	1920 MHz	40 MHz	40 MHz	0 MHz
37	1910 MHz	1930 MHz	1910 MHz	1930 MHz	20 MHz	20 MHz	0 MHz
1	1920 MHz	1980 MHz	2110 MHz	2170 MHz	60 MHz	60 MHz	130 MHz
36	1930 MHz	1990 MHz	1930 MHz	1990 MHz	60 MHz	60 MHz	0 MHz
23	2000 MHz	2020 MHz	2180 MHz	2200 MHz	20 MHz	20 MHz	160 MHz
34	2010 MHz	2025 MHz	2010 MHz	2025 MHz	15 MHz	15 MHz	0 MHz
40	2300 MHz	2400 MHz	2300 MHz	2400 MHz	100 MHz	100 MHz	0 MHz
30	2305 MHz	2315 MHz	2350 MHz	2360 MHz	10 MHz	10 MHz	35 MHz
41+7	2496 MHz	2690 MHz	2496 MHz	2690 MHz	194 MHz	194 MHz	0 MHz
38	2570 MHz	2620 MHz	2570 MHz	2620 MHz	50 MHz	50 MHz	0 MHz
42+22	3400 MHz	3600 MHz	3400 MHz	3600 MHz	200 MHz	200 MHz	0 MHz
43	3600 MHz	3800 MHz	3600 MHz	3800 MHz	200 MHz	200 MHz	0 MHz

Table 15—Frequency table after sub-bands unifications.

As it is possible to notice in the table above, sub-bands have very different bandwidths and gaps. The broader ones and those that contain a wide gap represent a concern to the precision of the parameters' specifications: selecting samples that are frequency-wise distant one from another means dealing with a dataset containing very different values (the difference between antennas pattern is proportional to the space between the frequencies they belong to). From a statistical point of view this would mean having weak averages and strong deviations. In order to address this issue, **sub-bands shall be splitted** into:

- Two new ones when the gap between the lowest and highest portion of sub-band is wider than 50 MHz. In this case the new sub-bands will coincide with the previous lower portion and higher portion. Those are now treated as “stand alone” sub-bands.
- A number of new, equally broad ones, if a portion (typically this happens for bands whose lower portion coincides with the higher one) is broader than 120 MHz. This number shall depend on the width of the new sub-bands, which shall be the broadest possible, but maximum 120 MHz wide. In case of asymmetric bands (case highlighted in yellow in Table 15), if they have to be divided, the portions nearest to the gap shall be kept as a sub-band. The resulting sub-bands can, in this case, also be asymmetric.



Example: Sub-Band 4+10 contains a gap of 340 MHz between its lower and higher portions. It will then be divided in sub-band “(4+10)a” and “(4+10)b”, whose frequency ranges are respectively: 1710-1770 MHz and 2110-2170 MHz.

Example: Assume sub-band 66 to be 1650-1780 MHz / 2110-2200 MHz. Since its lower portion would be 130 MHz wide and its higher portion 90 MHz wide, the lowest one should be split into two sub-bands: 1650-1715 MHz and 1715-1780 MHz / 2110-2200 MHz. The second sub-band would be, in fact, the combination of sub-band 66’s portions nearest to its frequency gap.

Cases in which these divisions take place are highlighted in orange in Table 15. After this process, the frequency table shall be sorted again (see beginning of this section) and should look as in the table below:

After division (sorted again)				
Band number	Lowest portion		Highest portion	
	start	stop	start	stop
31	452 MHz	458 MHz	462 MHz	468 MHz
12+28+44	639 MHz	803 MHz	639 MHz	803 MHz
17	704 MHz	716 MHz	734 MHz	746 MHz
29	717 MHz	728 MHz	717 MHz	728 MHz
67	738 MHz	758 MHz	738 MHz	758 MHz
13	746 MHz	756 MHz	777 MHz	787 MHz
14	758 MHz	768 MHz	788 MHz	798 MHz
20	791 MHz	821 MHz	832 MHz	862 MHz
27	807 MHz	824 MHz	852 MHz	869 MHz
26+18+5+19	814 MHz	849 MHz	859 MHz	894 MHz
8	880 MHz	915 MHz	925 MHz	960 MHz
11	1428 MHz	1448 MHz	1476 MHz	1496 MHz
21	1448 MHz	1463 MHz	1496 MHz	1511 MHz
32	1452 MHz	1496 MHz	1452 MHz	1496 MHz
(24)a	1525 MHz	1559 MHz	1525 MHz	1559 MHz
(24)b	1626 MHz	1660 MHz	1626 MHz	1660 MHz
(4+10)a	1710 MHz	1770 MHz	1710 MHz	1770 MHz
(66)a	1710 MHz	1780 MHz	1710 MHz	1780 MHz
3	1710 MHz	1785 MHz	1805 MHz	1880 MHz
(9)a	1750 MHz	1785 MHz	1750 MHz	1785 MHz
(9)b	1845 MHz	1880 MHz	1845 MHz	1880 MHz
(2+35+25)a	1850 MHz	1922 MHz	1850 MHz	1922 MHz
39+33	1880 MHz	1920 MHz	1880 MHz	1920 MHz
37	1910 MHz	1930 MHz	1910 MHz	1930 MHz
(1)a	1920 MHz	1980 MHz	1920 MHz	1980 MHz
(2+35+25)b	1922 MHz	1995 MHz	1922 MHz	1995 MHz
36	1930 MHz	1990 MHz	1930 MHz	1990 MHz
(23)a	2000 MHz	2020 MHz	2000 MHz	2020 MHz
34	2010 MHz	2025 MHz	2010 MHz	2025 MHz
(4+10)b	2110 MHz	2170 MHz	2110 MHz	2170 MHz
(1)b	2110 MHz	2170 MHz	2110 MHz	2170 MHz
(66)b	2110 MHz	2200 MHz	2110 MHz	2200 MHz
(23)b	2180 MHz	2200 MHz	2180 MHz	2200 MHz
40	2300 MHz	2400 MHz	2300 MHz	2400 MHz
30	2305 MHz	2315 MHz	2350 MHz	2360 MHz
(41+7)a	2496 MHz	2593 MHz	2496 MHz	2593 MHz
38	2570 MHz	2620 MHz	2570 MHz	2620 MHz
(41+7)b	2593 MHz	2690 MHz	2593 MHz	2690 MHz
(42+22)a	3400 MHz	3500 MHz	3400 MHz	3500 MHz
(42+22)b	3500 MHz	3600 MHz	3500 MHz	3600 MHz
(43)a	3600 MHz	3700 MHz	3600 MHz	3700 MHz
(43)b	3700 MHz	3800 MHz	3700 MHz	3800 MHz

Table 16—Frequency table after sub-bands divisions.

The listed sub-bands shall eventually be merged, splitted and sorted again by applying all the previously described rules, until no change to the table is possible anymore. Finally the frequency table should look as follows:

Band number	Lowest portion		Highest portion		B-width Low	B-width High	Gap
	start	stop	start	stop			
31	452 MHz	458 MHz	462 MHz	468 MHz	6 MHz	6 MHz	4 MHz
12+28+44	699 MHz	803 MHz	699 MHz	803 MHz	104 MHz	104 MHz	0 MHz
17	704 MHz	716 MHz	734 MHz	746 MHz	12 MHz	12 MHz	18 MHz
29	717 MHz	728 MHz	717 MHz	728 MHz	11 MHz	11 MHz	0 MHz
67	738 MHz	758 MHz	738 MHz	758 MHz	20 MHz	20 MHz	0 MHz
13	746 MHz	756 MHz	777 MHz	787 MHz	10 MHz	10 MHz	21 MHz
14	758 MHz	768 MHz	788 MHz	798 MHz	10 MHz	10 MHz	20 MHz
20	791 MHz	821 MHz	832 MHz	862 MHz	30 MHz	30 MHz	11 MHz
27	807 MHz	824 MHz	852 MHz	869 MHz	17 MHz	17 MHz	28 MHz
26+18+5+19	814 MHz	849 MHz	859 MHz	894 MHz	35 MHz	35 MHz	10 MHz
8	880 MHz	915 MHz	925 MHz	960 MHz	35 MHz	35 MHz	10 MHz
11	1428 MHz	1448 MHz	1476 MHz	1496 MHz	20 MHz	20 MHz	28 MHz
21	1448 MHz	1463 MHz	1496 MHz	1511 MHz	15 MHz	15 MHz	33 MHz
32	1452 MHz	1496 MHz	1452 MHz	1496 MHz	44 MHz	44 MHz	0 MHz
(24)a	1525 MHz	1559 MHz	1525 MHz	1559 MHz	34 MHz	34 MHz	0 MHz
(24)b	1626 MHz	1660 MHz	1626 MHz	1660 MHz	34 MHz	34 MHz	0 MHz
(4+10)a+(66)a	1710 MHz	1780 MHz	1710 MHz	1780 MHz	70 MHz	70 MHz	0 MHz
3	1710 MHz	1785 MHz	1805 MHz	1880 MHz	75 MHz	75 MHz	20 MHz
(9)a	1750 MHz	1785 MHz	1750 MHz	1785 MHz	35 MHz	35 MHz	0 MHz
(9)b	1845 MHz	1880 MHz	1845 MHz	1880 MHz	35 MHz	35 MHz	0 MHz
(2+35+25)a+39+33	1850 MHz	1922 MHz	1850 MHz	1922 MHz	72 MHz	72 MHz	0 MHz
37	1910 MHz	1930 MHz	1910 MHz	1930 MHz	20 MHz	20 MHz	0 MHz
(1)a+(2+35+25)b+36	1920 MHz	1995 MHz	1920 MHz	1995 MHz	75 MHz	75 MHz	0 MHz
(23)a+34	2000 MHz	2025 MHz	2000 MHz	2025 MHz	25 MHz	25 MHz	0 MHz
(4+10)b+(1)b+(66)b	2110 MHz	2200 MHz	2110 MHz	2200 MHz	90 MHz	90 MHz	0 MHz
(23)b	2180 MHz	2200 MHz	2180 MHz	2200 MHz	20 MHz	20 MHz	0 MHz
40	2300 MHz	2400 MHz	2300 MHz	2400 MHz	100 MHz	100 MHz	0 MHz
30	2305 MHz	2315 MHz	2350 MHz	2360 MHz	10 MHz	10 MHz	35 MHz
(41+7)a	2496 MHz	2593 MHz	2496 MHz	2593 MHz	97 MHz	97 MHz	0 MHz
38	2570 MHz	2620 MHz	2570 MHz	2620 MHz	50 MHz	50 MHz	0 MHz
(41+7)b	2593 MHz	2690 MHz	2593 MHz	2690 MHz	97 MHz	97 MHz	0 MHz
(42+22)a	3400 MHz	3500 MHz	3400 MHz	3500 MHz	100 MHz	100 MHz	0 MHz
(42+22)b	3500 MHz	3600 MHz	3500 MHz	3600 MHz	100 MHz	100 MHz	0 MHz
(43)a	3600 MHz	3700 MHz	3600 MHz	3700 MHz	100 MHz	100 MHz	0 MHz
(43)b	3700 MHz	3800 MHz	3700 MHz	3800 MHz	100 MHz	100 MHz	0 MHz

Table 17—Frequency table at the end of the merging/splitting/sorting processes.

None of the sub-bands listed above can be merged or splitted. At this time another issue should be considered: the algorithm described until now works with respect to a frequency table that is already standardized, but what just stated does not fully comply with the needs of the research & development, which generally cannot wait the amount of time essential to the processes that result in a standardization of the frequencies (therefore to a frequency table). Thus, extensions to the sub-bands are here contemplated, that is **an appendix up to 15 MHz wide may be added to a single portion of the sub-bands, whether before its start frequency or after its stop frequency.** Notice that at this point no merging or splitting is possible anymore, which means that from now on a sub-band may be maximum 135 MHz wide, and/or that a sub-band may overlap with (hardly contain) another one. For the sake of comprehension, in the table above the lower portion of the sub-band “(4+10)a+(66)a” will be extended to 1695-1780 MHz:

Band number	Lowest portion		Highest portion		B-width Low	B-width High	Gap
	start	stop	start	stop			
[3]*	1695 MHz	1785 MHz	1805 MHz	1880 MHz	90 MHz	75 MHz	20 MHz

Understandably, appendices cannot be enough if an antenna has to be measured within brand-new frequency ranges. The enlargement of the frequency table by inclusion of not yet standardized new sub-bands is permitted, supposing that a new “R&D” sub-band:

- Is not intended as a way to get around the application of all the rules described in Section 8.1 and its sub-sections.
- Has a gap narrower than 50 MHz.
- Has a bandwidth of maximum 120 MHz in its lower portion and 120 MHz in its higher portion.

In this whitepaper the sub-band “[X]*” will be added (see Table 18) in order to facilitate the comprehension:

Band number	Lowest portion		Highest portion		B-width Low	B-width High	Gap
	start	stop	start	stop			
[X]*	575 MHz	637 MHz	648 MHz	698 MHz	62 MHz	50 MHz	11 MHz

9.1.2 Frequency Samples Choice Method

After having determined the frequency table with the algorithm described in Section 9.1.1, the representative frequency samples for each sub-band shall be calculated by means of the following procedure. The number of samples for each one shall be variable and proportional to width of each sub-band’s portions. A portion will be represented by:

- One sample if its width is less than 10 MHz. In this case the sample shall be the middle frequency, that is between the start and stop frequencies of the portion.
- Two samples if its width is at least 10 MHz and less than 30 MHz. In this case the samples shall be the start and stop frequencies of the portion.
- Three samples if its width is at least 30 MHz and less than 60 MHz. In this case the samples shall be the start, middle and stop frequencies of the portion.
- Four samples if its width is at least 60 MHz. In this case the samples shall be the start frequency of the portion, the sample found by adding a third of the portion’s bandwidth to the start frequency, the sample found by subtracting a third of the portion’s bandwidth to the stop frequency, and the stop frequency itself.

Width [MHz]	Number of frequency samples	Samples
$W < 10$	1	$f_{start} + W/2$
$10 \leq W < 30$	2	f_{start} f_{stop}
$30 \leq W < 60$	3	f_{start} $f_{start} + W/2$ f_{stop}
$W \geq 60$	4	f_{start} $f_{start} + W/3$ $f_{stop} - W/3$ f_{stop}

Table 18—Frequency sampling.

All the samples calculated this way shall be approximated to the nearest unit of megahertz. Below the list of frequency samples associated to each sub-band:

Band number	Lowest portion		Highest portion		B-width Low	B-width High	Samples Low	Samples High	Lowest portion				Highest portion				
	start	stop	start	stop													
31	452 MHz	458 MHz	462 MHz	468 MHz	6 MHz	6 MHz	1	1	455 MHz				465 MHz				
[X]	575 MHz	637 MHz	648 MHz	698 MHz	62 MHz	50 MHz	4	3	575 MHz	596 MHz	616 MHz	637 MHz	648 MHz	673 MHz	698 MHz		
12+28+44	699 MHz	803 MHz	699 MHz	803 MHz	104 MHz	104 MHz	4	4	699 MHz	734 MHz	768 MHz	803 MHz	699 MHz	734 MHz	768 MHz	803 MHz	
17	704 MHz	716 MHz	734 MHz	746 MHz	12 MHz	12 MHz	2	2	704 MHz	716 MHz			734 MHz	746 MHz			
29	717 MHz	728 MHz	717 MHz	728 MHz	11 MHz	11 MHz	2	2	717 MHz	728 MHz			717 MHz	728 MHz			
67	738 MHz	758 MHz	738 MHz	758 MHz	20 MHz	20 MHz	2	2	738 MHz	758 MHz			738 MHz	758 MHz			
13	746 MHz	756 MHz	777 MHz	787 MHz	10 MHz	10 MHz	2	2	746 MHz	756 MHz			777 MHz	787 MHz			
14	758 MHz	768 MHz	788 MHz	798 MHz	10 MHz	10 MHz	2	2	758 MHz	768 MHz			788 MHz	798 MHz			
20	791 MHz	821 MHz	832 MHz	862 MHz	30 MHz	30 MHz	3	3	791 MHz	806 MHz	821 MHz		832 MHz	847 MHz	862 MHz		
27	807 MHz	824 MHz	852 MHz	869 MHz	17 MHz	17 MHz	2	2	807 MHz	824 MHz			852 MHz	869 MHz			
26+18+5+19	814 MHz	849 MHz	859 MHz	894 MHz	35 MHz	35 MHz	3	3	814 MHz	832 MHz	849 MHz		859 MHz	877 MHz	894 MHz		
8	880 MHz	915 MHz	925 MHz	960 MHz	35 MHz	35 MHz	3	3	880 MHz	898 MHz	915 MHz		925 MHz	943 MHz	960 MHz		
11	1428 MHz	1448 MHz	1476 MHz	1496 MHz	20 MHz	20 MHz	2	2	1428 MHz	1448 MHz			1476 MHz	1496 MHz			
21	1448 MHz	1463 MHz	1496 MHz	1511 MHz	15 MHz	15 MHz	2	2	1448 MHz	1463 MHz			1496 MHz	1511 MHz			
32	1452 MHz	1496 MHz	1452 MHz	1496 MHz	44 MHz	44 MHz	3	3	1452 MHz	1474 MHz	1496 MHz		1452 MHz	1474 MHz	1496 MHz		
(24)a	1525 MHz	1559 MHz	1525 MHz	1559 MHz	34 MHz	34 MHz	3	3	1525 MHz	1542 MHz	1559 MHz		1525 MHz	1542 MHz	1559 MHz		
(24)b	1626 MHz	1660 MHz	1626 MHz	1660 MHz	34 MHz	34 MHz	3	3	1626 MHz	1643 MHz	1660 MHz		1626 MHz	1643 MHz	1660 MHz		
(4+10)a+(66)a	1710 MHz	1780 MHz	1710 MHz	1780 MHz	70 MHz	70 MHz	4	4	1710 MHz	1733 MHz	1757 MHz	1780 MHz	1710 MHz	1733 MHz	1757 MHz	1780 MHz	
[3]	1695 MHz	1785 MHz	1805 MHz	1880 MHz	90 MHz	75 MHz	4	4	1695 MHz	1725 MHz	1755 MHz	1785 MHz	1805 MHz	1830 MHz	1855 MHz	1880 MHz	
(3)a	1750 MHz	1785 MHz	1750 MHz	1785 MHz	35 MHz	35 MHz	3	3	1750 MHz	1768 MHz	1785 MHz		1750 MHz	1768 MHz	1785 MHz		
(3)b	1845 MHz	1880 MHz	1845 MHz	1880 MHz	35 MHz	35 MHz	3	3	1845 MHz	1863 MHz	1880 MHz		1845 MHz	1863 MHz	1880 MHz		
(2+35+25)a+39+33	1850 MHz	1922 MHz	1850 MHz	1922 MHz	72 MHz	72 MHz	4	4	1850 MHz	1874 MHz	1898 MHz	1922 MHz	1850 MHz	1874 MHz	1898 MHz	1922 MHz	
37	1910 MHz	1930 MHz	1910 MHz	1930 MHz	20 MHz	20 MHz	2	2	1910 MHz	1930 MHz			1910 MHz	1930 MHz			
(1)a+(2+35+25)b+36	1920 MHz	1995 MHz	1920 MHz	1995 MHz	75 MHz	75 MHz	4	4	1920 MHz	1945 MHz	1970 MHz	1995 MHz	1920 MHz	1945 MHz	1970 MHz	1995 MHz	
(23)a+34	2000 MHz	2025 MHz	2000 MHz	2025 MHz	25 MHz	25 MHz	2	2	2000 MHz	2025 MHz			2000 MHz	2025 MHz			
(4+10)b+(1)b+(66)b	2110 MHz	2200 MHz	2110 MHz	2200 MHz	90 MHz	90 MHz	4	4	2110 MHz	2140 MHz	2170 MHz	2200 MHz	2110 MHz	2140 MHz	2170 MHz	2200 MHz	
(23)b	2180 MHz	2200 MHz	2180 MHz	2200 MHz	20 MHz	20 MHz	2	2	2180 MHz	2200 MHz			2180 MHz	2200 MHz			
40	2300 MHz	2400 MHz	2300 MHz	2400 MHz	100 MHz	100 MHz	4	4	2300 MHz	2333 MHz	2367 MHz	2400 MHz	2300 MHz	2333 MHz	2367 MHz	2400 MHz	
30	2305 MHz	2315 MHz	2350 MHz	2360 MHz	10 MHz	10 MHz	2	2	2305 MHz	2315 MHz	2350 MHz		2350 MHz	2360 MHz			
(4+7)a	2496 MHz	2593 MHz	2496 MHz	2593 MHz	97 MHz	97 MHz	4	4	2496 MHz	2528 MHz	2561 MHz	2593 MHz	2496 MHz	2528 MHz	2561 MHz	2593 MHz	
38	2570 MHz	2620 MHz	2570 MHz	2620 MHz	50 MHz	50 MHz	3	3	2570 MHz	2595 MHz	2620 MHz		2570 MHz	2595 MHz	2620 MHz		
(4+7)b	2593 MHz	2690 MHz	2593 MHz	2690 MHz	97 MHz	97 MHz	4	4	2593 MHz	2625 MHz	2658 MHz	2690 MHz	2593 MHz	2625 MHz	2658 MHz	2690 MHz	
(42+22)a	3400 MHz	3500 MHz	3400 MHz	3500 MHz	100 MHz	100 MHz	4	4	3400 MHz	3433 MHz	3467 MHz	3500 MHz	3400 MHz	3433 MHz	3467 MHz	3500 MHz	
(42+22)b	3500 MHz	3600 MHz	3500 MHz	3600 MHz	100 MHz	100 MHz	4	4	3500 MHz	3533 MHz	3567 MHz	3600 MHz	3500 MHz	3533 MHz	3567 MHz	3600 MHz	
(43)a	3600 MHz	3700 MHz	3600 MHz	3700 MHz	100 MHz	100 MHz	4	4	3600 MHz	3633 MHz	3667 MHz	3700 MHz	3600 MHz	3633 MHz	3667 MHz	3700 MHz	
(43)b	3700 MHz	3800 MHz	3700 MHz	3800 MHz	100 MHz	100 MHz	4	4	3700 MHz	3733 MHz	3767 MHz	3800 MHz	3700 MHz	3733 MHz	3767 MHz	3800 MHz	
(43)b	3700 MHz	3800 MHz	3700 MHz	3800 MHz	100 MHz	100 MHz	4	4	3700 MHz	3733 MHz	3767 MHz	3800 MHz	3700 MHz	3733 MHz	3767 MHz	3800 MHz	

Table 19—Samples associated to sub-bands’ portions.

When the lower and higher portions coincide, it means that there is actually only a single “block” of spectrum occupied by the associated sub-band, hence the samples appearing in both the portions columns are doubles, and only one occurrence of each one shall be taken into consideration when building the dataset that will be statistically analyzed. In this example, the list of frequency samples counts 124 unique frequencies to measure, in order to be able to evaluate the performances of a hypothetical antenna between 452 MHz and 3800 MHz in 37 different sub-bands.

Though, not every sample is needed. In the table above (and by extension in all the tables built following the procedures described until now) there are some samples that are very close one another, which means that there is a certain degree of redundancy that can be reduced through optimization. This shall be achieved by applying the following rules in their presented order:

- Each sample shall be compared to the following ones, after the list of samples is sorted in ascending fashion.
- Frequency samples belonging to “R&D sub-bands” shall always be removed from the list if there is already a sample 3 MHz or less (see third point) or 10 MHz or less (see fourth point) distant. Those shall be used instead. This is not applied to “appendices”.
- Under 1000 MHz:

- If three or more (the maximum is obviously four) adjacent frequency samples are 3 MHz or less distant one from each other, and the farthest ones have a difference of exactly 3 MHz, the samples in the middle shall be removed from the list.
 - If, instead, the difference is greater than 3 MHz, the last amongst the adjacent samples shall be preserved, and another one shall be chosen through a new comparison: if the distance between the preserved sample and the average between the first two adjacent ones is less than 3 MHz, the first sample shall be preserved too. Otherwise a new sample shall replace the first two ones, and its frequency will be equal to their average.
 - If two or more (the maximum is obviously three) adjacent frequency samples are less than 3 MHz distant one from each other, they shall be replaced by a single sample, whose frequency will be equal to the average of the two farthest replaced ones.
- If the cases described in the third point are verified for comparisons between frequency samples under 1000 MHz and above or exactly 1000 MHz, the rules of the third point shall be applied too.
- 1000 MHz and above:
 - If three or more adjacent frequency samples are 10 MHz or less distant one from each other, and the farthest ones have a difference of exactly 10 MHz, the samples in the middle shall be removed from the list.
 - If, instead, the difference is greater than 10 MHz, the last amongst the adjacent samples shall be preserved, and another one shall be chosen through a new comparison: if the distance between the preserved sample and the average between the first two adjacent ones is less than 10 MHz, the first sample shall be preserved too. Otherwise a new sample shall replace the first two ones, and its frequency will be equal to their average.
 - If two or more adjacent frequency samples are less than 10 MHz distant one from each other, they shall be replaced by a single sample.
 - Once samples have been replaced, they shall be rounded to the nearest unit of megahertz. The replaced ones shall be compared to the next ones in the list.

Below some examples:

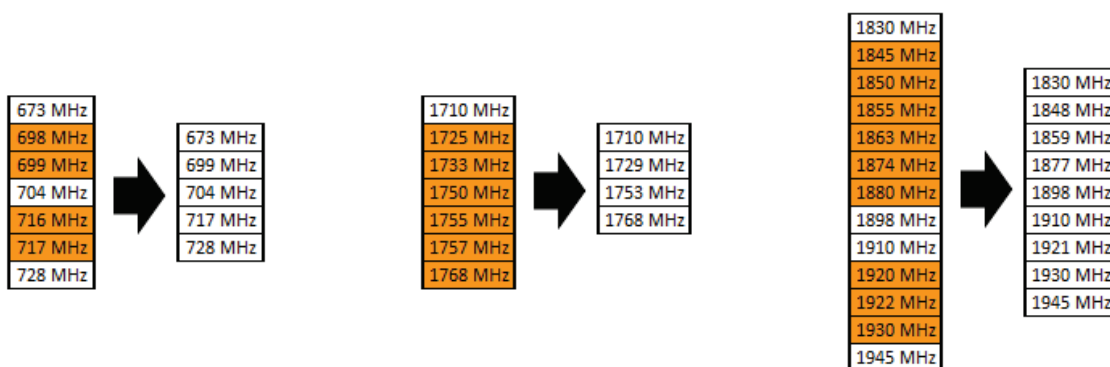

Figure 56—Examples of frequency samples redundancy optimization.



On the left (notice also that 698 MHz is one of the frequencies introduced by the R&D band [X]*) there are two cases where the highlighted frequency-samples are simply averaged. In the center there are a couple of "blocks" of samples to optimize one after the other: the first one goes from 1725 MHz to 1750 MHz. Since 1725 MHz and 1733 MHz averaged are more than 10 MHz distant from 1750 MHz, 1729 MHz and 1750 MHz appear in the "final samples" list. The second one goes from 1750 MHz (because it has been preserved) to 1768 MHz; the rules applied are the same. On the right there are also cases where only the middle sample is eliminated because the distance between 2 samples is exactly 10 MHz.

At this point, the only thing to do left is to replace the samples listed in Table 18 with the optimized ones. To do this, each frequency sample nearest to those to be replaced shall take their place. In case two samples are equally distant from the one to replace, the priority shall be given to the one inside the sub-frequency, and finally, if both are, to the higher one.

9.1.3 Compatibility with old whitepaper versions and use of non-BASTA frequencies

When a new frequency table is released and the frequency samples accordingly calculated, there can be two issues yet to deal with:

- The calculated frequency samples are not exactly those used by operators all over the world.
- Older antennas cannot be exactly compared to newer ones, due to difference in measured frequency samples.

In case of need, a specific non-BASTA frequency sample and the all the values (parameters, pattern level, etc.) associated to it can be calculated by linear interpolation between two frequency samples compliant with the latest version of this whitepaper. The proportion to use are the following:

$$\begin{aligned}(\text{Sample A} - \text{Sample B}) : 100 &= (\text{Sample A} - \text{Non-BASTA frequency sample}) : (100 - x) \\(\text{Value by sample A} - \text{Value by sample B}) : 100 &= (\text{Value by sample A} - \text{Value by interpolated sample}) : x\end{aligned}$$

This option shall be valid only for structures that are non-resonant between the selected frequencies. A maximum distance of 34 MHz between two frequency samples implicitly defined in this whitepaper guarantees (antenna's patterns are different in this neighborhood, but not extremely) a sufficient fidelity of the values obtained by interpolation to those that would be through a real measurement. Samples obtained through interpolation shall not be used but for internal purposes, and shall not be included in antennas' BASTA-compliant datasets.

Note: linear interpolations of the patterns would be the best way to obtain the specifications of another pattern, but it can be also fine to directly interpolate the parameters. The linear interpolation shall be performed between values in magnitude and not between values in dB.

9.2 Guidance on Pattern and Gain Measurements

A general guideline is that all equipment used for measurements of antennas patterns and gain should be calibrated with a visible proof of the latest calibration date. The following section give recommendations on the methodology to observe in order to correctly execute an antenna's measurement.

9.2.1 Mechanical Alignment of Test System

The mechanical boresight of the antenna and measurement system shall be calibrated by testing the antenna elevation pattern two times: once with the typical operating setup, while the second time the antenna mounting shall be rotated by 180 degrees or, if possible, the antenna mounting axis shall be flipped (recommended). In both cases the value of the measured antenna electrical tilt should be the same; contrarily, mechanics shall be realigned and tested again.

9.2.2 Phase Center Check

The antenna shall be rotated around its own phase center. To ensure that it happens, a pattern test on the middle frequency of each cluster shall be run to acknowledge the phase response over the azimuth. The outcome is a phase curve, which shall be flat in the angular region corresponding to the main beam of the antenna. If not, the antenna shall be positioned away from or towards the mechanical rotation center of the system, until it is aligned with the antenna phase center.

9.2.3 Antenna Pattern Testing

The system shall be set up to measure the antenna's patterns by the frequencies identified through the rules described in Section 9.1. A unique calibration shall be used for all the antenna's ports, and the test shall start from the minimum frequency supported by each cluster of the antenna and shall end with its supported maximum one. The azimuth and elevation patterns, Co-Pol and Cross-Pol shall be measured for each port and electrical downtilt of interest (see Section 4.2). These consist in the set of signal levels measured respectively by every azimuth and elevation degree of interest (see Section 4.2), which appear respectively in the same elevation and azimuth cuts where the absolute signal maximum lays. Signal levels can be in this way easily compared and evaluated relatively to each other. The resulting patterns shall have the antenna's mechanical boresight as an angular "zero-reference".

9.2.4 Pattern Accuracy Estimation

The following quick tests shall be performed before any measurement.

- When possible, a golden unit antenna with known performance (from another range) shall be tested.
- A pattern sweep (360 degrees) shall be run, and the signal level by -180° and $+180^\circ$ shall be checked. The signal levels should be identical since those point coincide, but they are measured with a time difference between them. If the signal level is not the same, this shall be taken as an indication of instability in the measurement setup, or of the surrounding environment. This issue should be further investigated (loose connections, signal interference, stability in instruments) before starting a measurement.
- A second pattern sweep shall be run with the antenna mounting rotated by 180° . At the end both patterns shall be checked for symmetry issues (right hand side of pattern in test 1 should look the same as left hand side of pattern in test 2). This test can give information of asymmetries in the measurement range (reflections or interfering signals from one direction).
- The two steps above are worth to be taken for both azimuth and elevation patterns.

9.3 Gain Measurement

In the following sections two methods to calculate the gain of an antenna will be described.

9.3.1 Gain by Substitution Method

The gain by substitution (also known as gain by comparison) method consists in a procedure that allows to measure an antenna's gain by using a reference antenna whose gain is already known, which is then compared with the AUT. The gain reference antenna is typically a calibrated standard gain horn.

- The first step in this procedure consists in calibrating the test range using the gain reference antenna by positioning it in its phase center and main beam direction, hence giving the system a "zero reference". This shall be done for each individual polarization of interest, since the transfer function of the range can be different for each polarization.
- The second step consists in measuring the antenna under test in its phase center and main beam direction.

The gain of the AUT is finally found by taking the measured values (step two), and adding the known gain of the reference antenna, which is typically found in a document delivered with it.

9.3.2 Gain by Directivity/Loss Method

An alternative gain measurement procedure is the gain by directivity/loss method. This one consists in a procedure that allows to measure an antenna's gain by measuring the directivity of an antenna and then considering its losses. Gain (G) and directivity (D) are in fact linked by the formula:

$$G = k \cdot D$$

with k representing the antenna efficiency factor ($0 \leq k \leq 1$), which describes the overall losses of the antenna ($k = 1$ means that the antenna is lossless). Therefore the antenna gain can be calculated by:

$$G[dB] = D[dB] - a_{\text{antenna}}[dB]$$

where a is the sum of all the antenna's losses.

Measuring the Directivity of an Antenna

To calculate the directivity, the field irradiated from an antenna shall be measured in every direction through the interaction of the AUT and a probe. This is achieved without any disturbance if the entire system is placed in an anechoic chamber (typically in near-field conditions) that allows the rotation of the AUT in both the spherical axis (theta and phi).

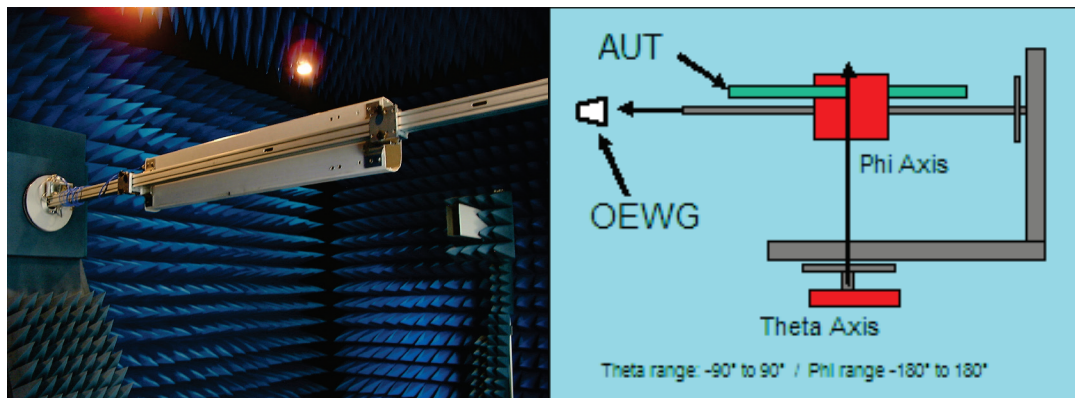

Figure 57—Spherical near-field system.

The directivity cannot be measured directly, but shall be computed from the far-field power pattern normalized to its maximum value:

$$D = \frac{4\pi}{\iint P_n(\theta, \phi) \sin \theta d\theta d\phi}$$

where D is once again the directivity and P_n the tridimensional power pattern.

In substance the directivity is calculated from a full tridimensional pattern measurement:

$$D[dB] = MaxFF[dB] - Powersum[dB] + 10 \cdot \log(4\pi)$$

where:

- *MaxFF* = Overall peak of the measured and computed FF.
- *Powersum* = Sum of all measured and computed far-field points (3D).

During the calculation of the directivity the following faults can cause problems:

- Shadowing effects of the scanner, which inexorably cause a wrong *Powersum* to be calculated.
- Probe correction error, which causes the software to perform wrong NF to FF transformations.
- Insufficient FFT density (sampling criteria should be carefully chosen during scanning and the near-to-far-field transformation), which causes aliasing.
- Wrong FF reference polarization, which causes false patterns to be measured.
- High Cr-Pol level in the measurement probe.

Measuring the Internal Losses of an Antenna

The antenna losses are the sum of the ohmic and dielectric losses between the input connector and the outer surface of the radome plus the loss due to the impedance mismatch:

$$a_{antenna} = a_{network} + a_{antennamismatch} + a_{radome}$$

The feeding loss $\alpha_{network}$ can be measured with a network analyzer as shown in the following picture:

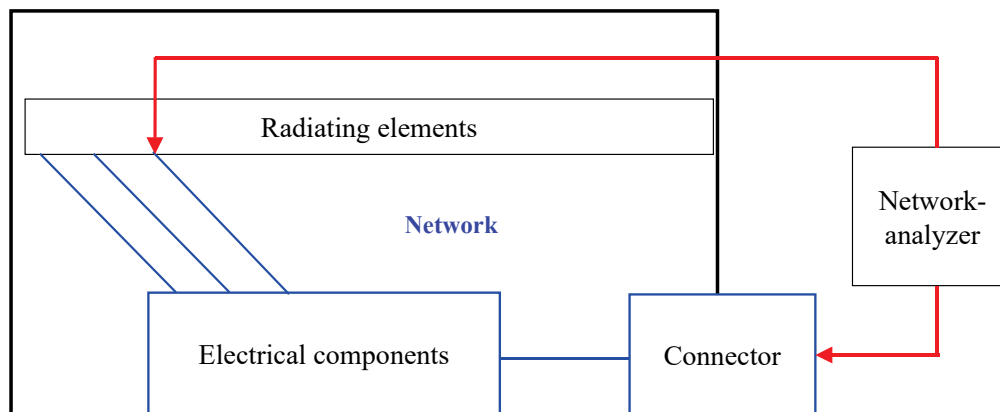

Figure 58—Block diagram of loss measurement.

This measurement shall be executed in four steps:

- Radiating elements shall be detached from the network.
- The transmission of each input-to-output path shall be measured.
- All the transmission losses of each path shall be summed.
- $\alpha_{network}$ shall be calculated as the average of the total transmission losses for each path.

The antenna mismatch has to be calculated with the formula:

$$a_{mismatch} = -10 \cdot \log_{10} \left(1 - e^{-\frac{RL}{10}} \right) [dB]$$

where RL is the return loss.

In the end, the overall network loss is:

$$a_{network} = a_{cables} + a_{components} + a_{network_mismatch}$$

The dielectric losses of the radome depend on its loss factor $\tan\delta$, which differs for each material. Under the assumption that the radome is normally thin, the value of $\tan\delta$ is less than 0.05dB and therefore can be neglected.

9.4 On the Accuracy of Gain Measurements

The following sections will detail potential sources of errors occurring during an antenna's gain measurement, and will give recommendations in order to minimize these errors. This discussion will be mainly focused on gain measurements done using the method of substitution and by means of far-field ranges (but its validity is extended to near-field gain measurements).

As a general rule it is strongly advised that all instruments have reached their working temperature before a calibration or a measurement, and that the measurement equipment is calibrated with the reference antenna as close in time as possible prior to the gain measurements. After the gain measurements have been performed, the reference antenna should be mounted and measured again against the previous calibration; should any deviation from it be observed, this shall be taken as an indication of instability in the measurement setup, or of the surrounding environment. This issue should be further investigated (loose connections, signal interference, stability in instruments) before repeating the measurement.

9.4.1 Antenna Mismatch between Reference Antenna and AUT

The measurement system is typically calibrated by the interface of the receiver (network analyzer) and not by the interface of antenna under test; under this assumption a difference between the VSWR of the reference antenna and the one under test is expected. This will result in an unavoidable (due to different reflections in the measurements) calibration error. Divergently from the IEEE gain definition, the power reflected due to mismatch is not compensated for, and the above mentioned error is estimated to be ~0.1dB. In order to minimize it, though, it is recommended that long measurement cables are used, and that the measurement of their RL towards the network analyzer is < -20 dB.

9.4.2 Size Difference between Reference Antenna and AUT

In condition of far-field an antenna's quiet zone is never ideal, but instead characterized by amplitude and phase variations that are dependant on the size of the antenna's aperture. Considering that the aperture of an AUT typically differs from the one associated to a reference antenna (normally a standard gain horn), a measurement error between 0.1 dB and 0.2 dB can typically be taken into account.

Theoretically, if for each frequency the AUT would be moved in a plane perpendicular to a planar wave coming from the probe, and defined by the averages of both the antennas lengths and widths (also oriented along the same antennas' axis), the gain would be obtained as a function of AUT's displacement. Integrating the gain found in the whole area (basically the average aperture) would minimize the above

mentioned error, as the differences in the quiet zones would be minimized too. Doing this, though, is unpractical and very time-consuming, so the mentioned error is accepted instead.

9.4.3 Temperature and Humidity Drift in Instruments

The signal level measured at the receiver (network analyzer) depends on the surrounding environment conditions. To avoid temperature and/or humidity drifts, the measurement equipment shall be placed in a controlled environment (see Section 7).

9.4.4 Polarization

In the measurement chamber the transfer function is not the same for different polarizations, therefore in order to avoid errors each polarization shall be individually calibrated.

9.4.5 Direct Gain Comparison Between Two Antennas

The gain difference between two similar (shape, sizes, frequencies, tilt) antennas can be quite accurately determined by using the gain by comparison method. In this case the power level difference between the AUT and the reference antenna (which in this case is not a standard gain horn, but an already measured antenna) corresponds to the difference in gain between the two.

9.4.6 Reference Antennas

Reference antennas should be absolutely calibrated and shall periodically be checked/recalibrated. Due to errors in the absolute calibration method a deviation of ~ 0.2 dB from the published values shall always be estimated.

9.5 Guidance on Production Electrical Testing

In order to validate the performance and quality of each antenna produced, the following best practices for the production testing of each BSA should be observed by manufacturers:

- VSWR (or RL) and isolation:
 - Measurement shall be performed under condition such that radiated power is not reflected back into the antenna, and that other radiated power cannot be received through the antenna.
 - VNA calibration shall be performed at least once per day (once per shift).
 - For variable downtilt antennas, the RL and isolation shall be measured through the full tilt range and the worst case value shall be recorded.
 - Final test plots shall be provided with the antenna upon request.
- PIM:
 - Measurement shall be performed under condition such that radiated power is not reflected back into the antenna, and that other radiated power cannot be received through the antenna.
 - Connectors shall be clear of debris and void of damage.
 - Power shall be verified at the end of the test cable to ensure appropriate carrier power is fed to the antenna under test. If not done, the test cable loss could mask the true PIM levels.
 - Equipment noise floor shall be validated/calibrated using a low-PIM load.
 - Measurement shall be performed in swept mode (with one of the two test tones sweeping in frequency).
 - Dynamic stress shall be placed on the antenna during PIM testing.
 - For variable downtilt antennas, the PIM shall be measured through the full tilt range and the worst case value shall be recorded.

- Measuring PIM performance in the sub-band nearest to the middle frequency of the entire bandwidth is generally sufficient to characterize the PIM performance for the whole cluster.
- Final test plots shall be provided with the antenna upon request.
- For antennas with cabled corporate feed networks, a quality check process shall be implemented to assure that the cables are wired properly.
- General Comments:
 - Valid equipment calibration stickers should be visible on production equipment.
 - Test technicians should be properly trained.

9.6 Recommend Vendor’s Reference Polarization Labelling Convention

Given the legacy issue of vendors having defined slant 45° polarizations using different naming conventions and geometries, a labeling convention approach is recommended as opposed to harmonizing vendors on a common polarization naming convention. This will avoid inconsistency with an existing installed base of antennas; it does, however, require installers’ attention to interpreting and comparing the labels of different vendors.

The labeling convention requires vendors to define the polarization geometry and naming convention they have adopted for their antenna products and to depict this information clearly on a label placed on the antenna. The convention is then applied to each antenna port, which must be also labeled to allow the identification of its polarization.

Below an example of a vendor label defining a polarization geometry and naming convention, and picture illustrating an example of labeling on the rear side of an antenna:

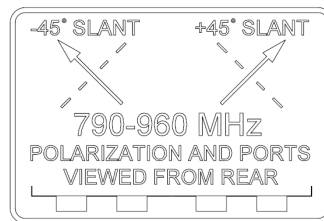

Figure 59—Example of polarization conventional label.

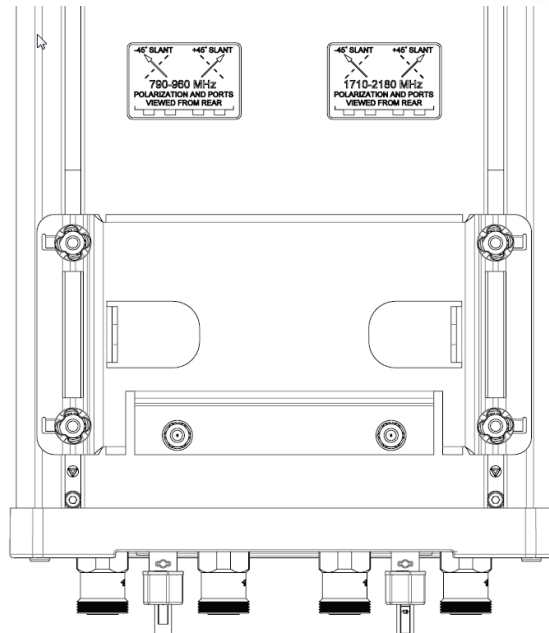

Figure 60—Polarization conventional label affixed on the antenna back.

Finally, an example of the ports labeling per the convention described on the antenna:

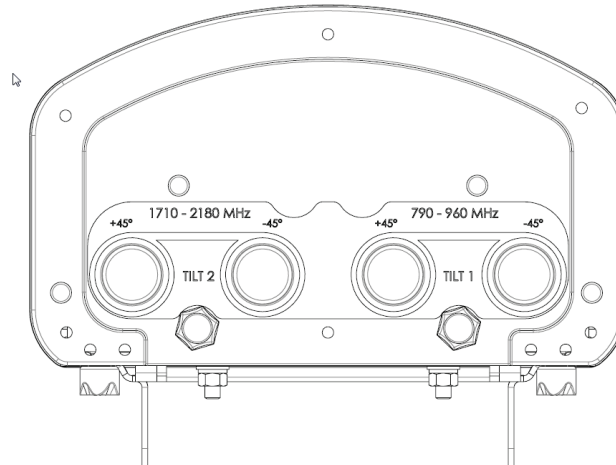

Figure 61—Ports identified by polarization.

10 Format for the Electronic Transfer of Specification Data

Antenna vendors are expected to disclose antennas' specifications through datasheets. In the past this was done by providing the final user with paper documents, but since it has become common practice that operators request data in electronic format in addition, it is useful to have an agreed upon format for electronic data interchange. Requirements for the above mentioned format were identified in:

- Very limited flexibility for providing information outside the agreed content.
- Easiness of exchange (export / import of data).
- No dependency on any proprietary software.
- Low to no risk of file structure or format (extension etc.) change.

XML was elected as the only format for electronic data interchange to be recommended in this whitepaper. It consists in an open-standard system that defines rules to encode informations in a file, and due to its readability and simplicity, at the time the edit of this whitepaper it was largely widespread. XML files can populate databases by being loaded through specific XML-reader softwares, but can also be loaded from the most common web-browsers and word-processors for a fast consultation.

XML key terminology will be extensively used in the next sections, so for a quick reference it is helpful to list the most important definitions:

- A **tag** is a line of text contained inside the two markup symbols “<” and “>”. Tags are defined as:
 - Start tag (e.g.: <tag>).
 - End tag (e.g.: </tag>).Some tags can also have a structure that allows them to start and end in the same string, such as:

- <tag element/>

- Between start and end of a tag there is an **element** that is a logical “block”, which can contain only a number of attributes as in the following example:

```
<tag name1="value1" name2="value2"/>
```

or one or more tags as shown below:

```
<tag>
  <child_tag>
    <grandchild_tag name1="value1" name2="value2"/>
  </child_tag>
</tag>
```

where the element of `tag` is everything enclosed between its start and end tags.

- An **attribute** is a set of two entities: **name** and **value** (see examples above), which are linked together by an equality.

More information on XML specifications can be easily found on the web.

10.1 XML use for BSA specifications

As already written, XML defines a set of general rules to encode documents, but it is also necessary, for the scope of this whitepaper, to have agreements on the structure and content of the very NGMN P-BASTA XML-code, so that it can be easily read both by machines and humans, yet fulfilling the requirement to be a satisfying datasheet for an antenna.

- An XML file shall have an unambiguous name, structured in accordance to the antenna’s datasheet name and version (see Section 10.1.1).
- An XML file shall never contain any information on how to obtain (measure or calculate) the values of an antenna’s parameters, their definition or specification, their measurement units or, more in general, anything that is already covered by this whitepaper.
- An XML file shall not contain informations unrelated to this whitepaper (e.g.: new parameters, alternative calculations, etc.).
- Every user interested in the use of XML files for BSA specifications shall be redirected to this document upon request of information.

- The order of the tags in an element and the order of the attributes in a tag shall not be arbitrary, so that the general structure of the code remains the always the same for everyone (in the appendices there are complete XML structure samples of a fictitious antenna and of a fictitious RET).
- All the tags are treated as not case sensitive, but in this whitepaper it is recommended that tags and attributes are written with lower case characters only, and with the underscore symbol (“_”) for separating words. The values of attributes are an exception to this rule and may contain uppercase letters and/or spacing.
- Comments can be used everywhere (see XML comment syntax on the web).
- Decimal numbers shall always be written with the full stop symbol (“.”) and not with comma (“,”).
- Each tag in the XML code shall have the optional Boolean attribute `applicable`, that can be set to `applicable="false"` if, for some reason, the tag refers to parameter that cannot be measured or calculated by its definition. In that case all the elements belonging to the tag shall not be taken in account (attributes values can be random).

The XML code structure shall reflect the logical structure of antennas, which can be schematized as shown in the following picture:

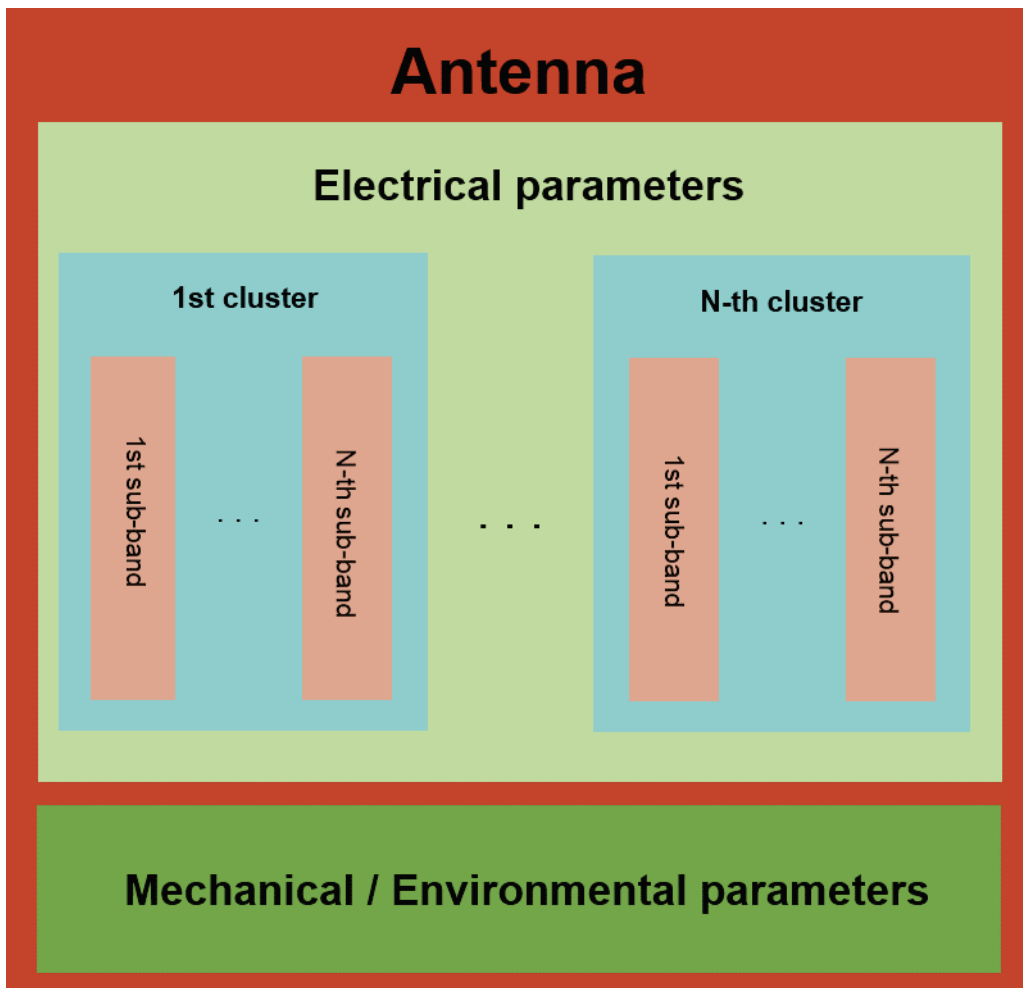

Figure 62—Block-scheme of an antenna.

Corresponding to the block scheme illustrated above, the XML code shall be structured as follows:

```

<antenna vendor="X" model="Y" description="Z">
  <!-- parameters tags to be inserted here -->
  <electrical_specifications>
    <!-- parameters tags to be inserted here -->
    <cluster name="1st">
      <!-- first frequency sub-range -->
      <frequency_sub_range start="XX" stop="YY">
        <!-- parameters tags to be inserted here -->
      </frequency_sub_range>
      <!-- more frequency sub-ranges -->
      <!-- last frequency sub-range -->
      <frequency_sub_range start="WW" stop="ZZ">
        <!-- parameters tags to be inserted here -->
      </frequency_sub_range>
    </cluster>
    <!-- more clusters -->
    <cluster name="n-th">
      <!-- first frequency sub-range -->
      <frequency_sub_range start="XXX" stop="YYY">
        <!-- parameters tags to be inserted here -->
      </frequency_sub_range>
      <!-- more frequency sub-ranges -->
      <!-- last frequency sub-range -->
      <frequency_sub_range start="WWW" stop="ZZZ">
        <!-- parameters tags to be inserted here -->
      </frequency_sub_range>
    </cluster>
  </electrical_specifications>

  <mechanical_specifications>
    <!-- parameters tags to be inserted here -->
  </mechanical_specifications>

  <miscellaneous_data>
    <!-- more tags to be inserted here -->
  </miscellaneous_data >
</antenna>

```

This architecture allows the larger blocks/elements to include specifications that are valid for all the blocks/elements that they contain, while the smallest one describe a very specific part of the antenna.



A number of tags and attributes, which were not discussed in the appropriate parameters sections, shall be used to complete the antenna's logic structure. Those will be discussed in the following sections.

10.1.1 Filename

Each XML file shall be labeled in a way that readily indicates the content version, thus providing version tracking when multiple files occupy the same folder. The filename should also allow a user (human or machine) to easily identify basic information about the datasheet contained, and perform basic queries between files to find a specific version of an antenna's datasheet. A filename shall always be written with uppercase letters, and its archetype shall be:

BASTAVERSION_VENDORNAME_ANTENNANAME, PAN, FAN_DATE_VERSION_STATUS

where:

- **BASTAVERSION** is the version of the NGMN-P-BASTA whitepaper that has been used to create the XML file. The symbol of full stop (".") in the version string shall be replaced with the symbol of minus ("-").
- **VENDORNAME** is the name of the antenna's vendor.
- **ANTENNANAME** is the name of the antenna model.
- **PAN** is the combination of the string "PAN" and the value in degrees of a specific antenna pan angle (see Section 3.3.16). This value shall be identified by a letter indicating the sign ("P" for "plus" and "M" for "minus") and three figures, which shall vary between "000" and "359". "000" shall always be preceded by "P". Moreover if an antenna has no pan capability, **PAN** shall be an empty string, and the comma before it shall be deleted.
- **FAN** is the combination of the string "FAN" and the value in degrees of a specific antenna fan angle (see Section 3.3.17). This value shall be identified by three figures, which shall vary between "001" and "360". Moreover if an antenna has no fan capability, **FAN** shall be an empty string, and the comma before it shall be deleted.
- **DATE** is the date in which the datasheet inside the file was created. The format to use shall be YYYY-MM-DD (four numbers for the year, two for the month and two for the day).
- **VERSION** is written with a "v" letter and followed by two numbers. It represents the version of the datasheet contained in the file. The first version shall always be the "00". Along with **DATE**, ensures that there can be a maximum of 100 datasheets of the same antenna created in one day.
- **STATUS** shall describe the datasheet status. Only two values of it shall be possible: **F** (for "final") and **P** (for "preliminary").
- The extension of the file shall be ".xml"

An example of filename of an antenna capable of panning and fanning:

BASTA10-0_RFS_APXV99LL20BI-U, PANM150, FAN010_1999-12-30_V00_F.xml

An example of filename of an antenna not capable of panning and fanning:

BASTA10-0_RFS_APXV88LL25BI-U_2000-08-12_V10_F.xml

10.1.2 Preamble

The preamble is a part of code that was not mentioned before. It is nevertheless worth to dedicate a section to it due to the fact that it completes the code with useful informations. It contains only two tags:

XML version and encoding:

```
<?xml version="1.0" encoding="UTF-8"?>
```

This is defined by the XML format. For information concerning this tag, it is recommended to refer to the appropriate documentation on the web.

BASTA and its version:

```
<basta version="9.0.1">
```

The `basta` tag opens the datasheet, and its first attribute `version` points to the version of the NGMN-P-BASTA whitepaper that has been used to create the XML file. The value associated to it shall be a string containing the version number, which shall be the same one used to generate the filename (see Section 10.1.1).

A tag dedicated to annotations belongs to the `basta` tag too:

```
<annotation>here you can write what you want</annotation>
```

10.1.3 Antenna

The antenna element is the largest block and contains informations that characterize/are valid for the whole antenna:

Antenna name, brand and description:

```
<antenna vendor="huawei" model="atr4517r1" description="dxxx-790-960/1710-2690/1710-2690-65/65/65-15i/17.5i/17.5i-m/m/m-r">
```

All the three attributes contain a string that describes respectively the antenna's vendor, the antenna model and a brief description of the antenna itself. `vendor` and `model` shall coincide respectively with `VENDORNAME` and `ANTENNANAME` in the filename (see Section 10.1.1). This redundancy has been added to avoid mistakes during XML files renaming. Files whose name and `antenna` tag don't coincide should not be used.

Datasheet replacement:

```
<replacement_datasheet datasheet="BASTA9-6_COMMSCOPE_SBNHH-1D65B,FAN065_2001-01-01_V10_P"/>
```

`replacement_datasheet` is an optional tag that shall appear as an element inside `antenna` when the datasheet contained in the file replaces a previous version of itself. An antenna replacing an older model typically changes instead its name, therefore its datasheet shall not be taken as a substitute to an older one, but as a brand-new datasheet. The value of `datasheet` shall be a string equal to the name of the replaced datasheet without the ".xml" extension. Notice that the value of `datasheet` is written with uppercase letters.

10.1.4 Electrical Specifications

The `electrical specifications` block is the only element containing antennas' parameters concerning its radiation pattern and electrical features. It contains every cluster block and two other elements that have no child tags:

Maximum power for the whole antenna:

```
<maximum_effective_power_antenna value="1200"/>
```

This tag is basically self-explanatory. Its `value` attribute shall be a positive integer number.

Nominal directions for multi-beam antennas:

```
<nominal_directions value="XXX ; YYY ; ZZZ"/>
```

Only if the antenna is a multi-beam one, this tag shall designate the angles of each beam's nominal direction. Its only attribute shall be a string of integer numbers (positive and/or negative), which shall be separated by the ";" combination of characters. It shall be implicitly assumed that angles are associated to each cluster in the same order as both are shown (e.g. XXX -> first cluster in code, YYY -> second cluster in code, etc.).

10.1.5 Cluster

Inside a cluster block there are all the parameters that belong to the specific section of the antenna connected to a number of ports (typically two). A cluster is, in fact, defined by more tags, which contain its core informations: name, ports and supported frequencies.

Cluster name:

```
<cluster name="r1"/>
```

In the `name` attribute it is useful to have a basic information on the set of frequencies supported by the cluster directly. Therefore the name that shall be used is the same string that would be found through the application of the latest "AISG specification for antenna ports color coding".

Ports:

```
<port name="1" polarization="+45" location="bottom" connector_type="7-16"/>
```

```
<port name="2" polarization="-45" location="bottom" connector_type="7-16"/>
```

As already stated, the `port` tags complete, along with its name and supported frequencies, the definition of a cluster. Port `name` and `polarization` shall be strings whose values shall follow the recommendations given in the latest "AISG specification for antenna ports color coding" document. For a single cluster there are typically two ports.

Supported frequencies:

```
<frequency_range start="698" stop="960"/>
```

The `frequency_range` tag gives the user insight into the cluster's supported frequencies. All the ports associated to the cluster shall support all the frequencies between `start` and `stop` (included). These

two attributes shall be equal to a positive integer value (rounded to the nearest unit, if necessary) with `stop > start`.

Note: a cluster can support a broader band than the broadest combination of all the sub-bands specified by the vendor in the sub-frequencies block (see Section 10.1.6).

Other tags contained in cluster:

TAG	Attribute variable format
<code><mechanical_boresight value="XXX"/></code>	Integer number between -180 and 180
<code><nominal_horizontal_half_power_beamwidth value="XXX"/></code>	Integer number between 0 and 360
<code><electrical_downtilt start="XXX" stop="XXX"/></code>	Both numbers with a single decimal place. <code>stop > start</code>
<code><isolation_interband value="XXX"/></code>	Positive integer number
<code><impedance value="XXX"/></code>	Positive integer number
<code><vswr value="XXX"/></code>	Positive number with a single decimal place
<code><return_loss value="XXX"/></code>	Positive integer number
<code><passive_intermodulation value="XXX"/></code>	Negative integer number
<code><maximum_effective_power_per_port value="XXX"/></code>	Positive integer number
<code><maximum_effective_power_cluster value="XXX"/></code>	Positive integer number

10.1.6 Sub-Band

A frequency sub-band block is a section of a cluster that characterizes only a part of its whole supported spectrum. It is the smallest logical block but also the most specific, also because it contains the highest number of parameters. A sub-band block has no name and is uniquely defined by its frequency range.

Sub-Band:

`<frequency_sub_range start="698" stop="806"/>`

All the parameters included in `frequency_sub_range` shall only be associated to the specified frequency range between `start` and `stop` (included). These two attributes shall be equal to a positive integer value (rounded to the nearest unit, if necessary) with `stop > start`. `start` cannot be lower than the cluster's `frequency_range start`; similarly, `stop` cannot be higher than the cluster's `frequency_range stop`.

All tags contained in sub-band:

TAG	Attribute variable format
<code><gain_at_tilt min="XXX" mid="XXX" max="XXX"/></code>	All positive numbers with a single decimal place
<code><gain_over_all_tilts value="XXX" tolerance="XXX"/></code>	Both positive numbers with a single decimal place
<code><azimuth_interference_ratio value="XXX" tolerance="XXX"/></code>	Both positive numbers with a single decimal place

<code><azimuth_beamwidth value="XXX" tolerance="XXX"/></code>	Both positive numbers with a single decimal place
<code><azimuth_beam_squint value="XXX" tolerance="XXX"/></code>	Both positive numbers with a single decimal place
<code><azimuth_beam_port_to_port_tracking value="XXX"/></code>	Positive number with a single decimal place
<code><azimuth_beam_hv_tracking value="XXX"/></code>	Positive number with a single decimal place
<code><azimuth_beam_roll_off value="XXX" tolerance="XXX"/></code>	Both positive numbers with a single decimal place
<code><elevation_beamwidth value="XXX" tolerance="XXX"/></code>	Both positive numbers with a single decimal place
<code><elevation_downtilt_deviation value="XXX"/></code>	Positive number with a single decimal place
<code><front_to_back_ratio_total_power_pm30 value="XXX"/></code>	Positive number with a single decimal place
<code><front_to_back_ratio_over_30_angular_region_total_power_az_and_el value="XXX"/></code>	Positive number with a single decimal place
<code><null_fill value="XXX"/></code>	Positive number with a single decimal place
<code><upper_sidelobe_suppression_first value="XXX"/></code>	Positive number with a single decimal place
<code><upper_sidelobe_suppression_peak_to_20 value="XXX"/></code>	Positive number with a single decimal place
<code><upper_sidelobe_suppression_horizon_to_20 value="XXX"/></code>	Positive number with a single decimal place
<code><upper_sidelobe_suppression_maximum_level value="XXX"/></code>	Positive number with a single decimal place
<code><cross_polar_discrimination_over_sector value="XXX"/></code>	Positive number with a single decimal place
<code><cross_polar_discrimination_at_mechanical_boresight value="XXX"/></code>	Positive number with a single decimal place
<code><cross_polar_discrimination_over_3_db_azimuth_beamwidth value="XXX"/></code>	Positive number with a single decimal place
<code><cross_polar_discrimination_over_10_db_azimuth_beamwidth value="XXX"/></code>	Positive number with a single decimal place
<code><cross_polar_discrimination_over_3_db_elevation_beamwidth value="XXX"/></code>	Positive number with a single decimal place
<code><cross_polar_discrimination_over_10_db_elevation_beamwidth value="XXX"/></code>	Positive number with a single decimal place
<code><isolation_cross_polar value="XXX"/></code>	Positive number with a single decimal place

Note: Tolerances are intended as plus or minus (\pm).

10.1.7 Mechanical and Environmental Specifications

The mechanical and environmental block encompasses, under the `mechanical_specifications` tag, the following elements:

TAG	Attribute variable format
<code><dimensions height="XXX" width="XXX" depth="XXX" reference="XXX"/></code>	All positive integer numbers except <code>reference</code> that is an optional string enumeration.
<code><packing_size height="XXX" width="XXX" depth="XXX"/></code>	All positive integer numbers
<code><net_weight wo_mtg_hardware="XXX" only_mtg_hardware="XXX"/></code>	Both positive numbers with a single decimal place
<code><shipping_weight value="XXX"/></code>	Positive number with a single decimal place
<code><survival_wind_speed value="XXX"/></code>	Positive integer number
<code><radome_material value="XXX"/></code>	String
<code><radome_color value="XXX"/></code>	String
<code><lightning_protection value="XXX"/></code>	Boolean
<code><mechanical_distance_between_mounting_points_antenna value="XXX"/></code>	Positive integer number > <code>antenna_dimensions height</code>

There is also a variable number of environmental specifications included in the same element (see Section 5.11). Below an example:

TAG	Attribute variable format
<code><product_environmental_compliance_general standard="XXX" compliance="XXX"/></code>	Both strings
<code><product_environmental_compliance_transportation standard="XXX" compliance="XXX"/></code>	Both strings
<code><product_environmental_compliance_environmental_conditions standard="XXX" compliance="XXX"/></code>	Both strings
<code><product_environmental_compliance_storage standard="XXX" compliance="XXX"/></code>	Both strings
<code><product_environmental_compliance_package standard="XXX" compliance="XXX"/></code>	Both strings

10.1.8 Miscellaneous data

Finally, there is an element of `antenna` that cannot be considered as a part of the antenna's block architecture: `miscellaneous_data`. It contains only two tags:

Compatible RETs:

```
<compatible_ret value="86010148v01 ; 86010153"/>
```

This tag's attribute `value` is actually a string containing a list of RETs models that are compatible to the antenna; their names shall be separated by the " ; " string. It will be assumed that the vendor of these RET models is the same of the antenna's.

Comments:

```
<vendor_comments value="antenna clamps included ; ret included"/>
```

Since traditionally the vendors include in their paper datasheets more information about the antenna (such as: optionals, pieces included in the package, etc.) rather than specifying only parameters values, `vendor_comments` is an optional tag merely thought for vendors to provide additional information regarding the antenna. Its only attribute shall be a string containing a set of comments separated by the " ; " combination of characters.

10.2 XML use for RET specifications

Block-scheme-wise a RET is, as a matter of fact, an appendix to an antenna (even if the RET is integrated), hence it can be described by a stand-alone file, whose structure follows all the rules defined in the previous paragraph and all its relevant comprehended sections (Sections 10.1 to Section 10.1.3). The `ret` tag contains only the following elements:

TAG	Attribute variable format
<code><replacement_datasheet datasheet="XXX"/></code>	String (filename)
<code><standalone_dimensions height="XXX" width="XXX" depth="XXX"/></code>	All positive integer numbers
<code><installed_dimensions height="XXX" width="XXX" depth="XXX" reference="XXX"/></code>	All positive integer numbers except <code>reference</code> that is a string enumeration.
<code><working_temperature_range min="XXX" max="XXX"/></code>	Both integer numbers > -273 with <code>max</code> > <code>min</code>
<code><power_consumption low_power="XXX" high_power="XXX"/></code>	Both positive numbers with a single decimal place and <code>high power</code> > <code>low power</code>
<code><lose_position_on_power_failure value="XXX"/></code>	Boolean
<code><compatible_standards value="XXX ; YYY ; ZZZ"/></code>	String
<code><compatible_protocols value="XXX ; YYY ; ZZZ"/></code>	String
<code><configuration_management value="XXX"/></code>	String Enumeration
<code><antenna_configuration_available value="XXX"/></code>	Boolean
<code><antenna_configuration_upgradable value="XXX"/></code>	String Enumeration
<code><software_upgradable value="XXX"/></code>	String Enumeration
<code><field_replacement_allowed value="XXX"/></code>	String Enumeration
<code><visual_indicator_available_on_tilt_change value="XXX"/></code>	Boolean
<code><daisy_chain_available value="XXX"/></code>	Boolean



APPENDIX A – EXAMPLE OF ANTENNA DATASHEET

This is an example of single-beam antenna, whose datasheet replaces the older one. In this example the cluster "R1" has a required parameter not applicable. All the data in the following examples is fictional.

NGMNP-BASTA-Verzian		10.0					
Vendor Name		KATHREIN					
Antenna Type		0000001W02					
Datasheet creation date		2017-01-01		Status		Final	
Version		V00					
Antenna Description		XXXXPal Power103-814/1035-1032/2431-3531 E1-755-755-102/102/102/102-1E/2.5-12/2.5-12-T					
Datasheet Replacement							
Electrical Specifications							
Asimuth Beam Pan Angle		deg					
Max. Effective Power Antenna		W		1000			
Cluster Name		B1		B1		V1	
Part Name		1		2		3	
Polarization		+45		-45		+45	
Mechanical Orientation		deg		-45		-45	
Nominal Horizontal HPBW		deg		65		65	
Asimuth Beam Pan Range		deg		Start		Stop	
Asimuth Beamwidth Pan Range		deg		Start		Stop	
Electrical Down tilt		deg		Start		Stop	
Impedance		Ω		50		50	
VSWR		dB		1.5		1.5	
Return Loss		dB		14		14	
Interband Isolation		dB		30		30	
PIM		dBc		-150		-150	
Max. Effective Power per Part		W		300		300	
Max. Effective Power per Cluster		W		600		600	
Frequency range		MHz		Start		Stop	
Frequency sub-range		MHz		699 - 803		894 - 814	
Gain		dBi		Min Tilt		14.0	
				Mid Tilt		14.2	
				Max Tilt		13.9	
				Over all Tilt		14.1 +/- 2.6	
Cross Polar Isolation		dB		28		28	
Horizontal Pattern							
Asimuth Beamwidth		deg		65.0 +/- 3.5		63.0 +/- 3.8	
Asimuth Beam Squint		deg		1.4 +/- 2.8		1.0 +/- 2.1	
Asimuth Beam Part-to-Part Tracking		dB		1.3		1.3	
Asimuth Beam HW Tracking		dB					
Asimuth Beam Roll-Off		dB		+/-		+/-	
Front-to-Back Ratio Total Power +/- 30°		dB		21.7		23.2	
Front-to-Back Ratio Total Power +/- 30° AZ EL		dB		21.7		23.2	
Cross Polar Discrimination Over Sector		dB		8.7		7.8	
Cross Polar Discrimination at Mechanical Bearing		dB		21.0		23.2	
Cross Polar Discrimination over 3dB AZ Beamwidth		dB		13.1		13.4	
Cross Polar Discrimination over 10dB AZ Beamwidth		dB					
Asimuth Interference Ratio		dB		+/-		+/-	
Vertical Pattern							
Elevation Beamwidth		deg		14.1 +/- 1.2		14.1 +/- 1.1	
Elevation Down tilt Deviation		deg		0.5		0.5	
First Upper Side lobe Level		dB		12.4		14.3	
Upper Side lobe Level peak to 20° above		dB		12.3		13.8	
Upper Side lobe Level Horizontal 20°		dB					
Maximum Upper Side lobe Level		dB		33.9		32.6	
Null Fill		dB					
Cross Polar Discrimination over 3dB EL Beamwidth		dB					
Cross Polar Discrimination over 10dB EL Beamwidth		dB					
Mechanical Specifications							
Antenna Dimension: Height / Width / Depth		mm		1250		378	
Packing Size: Height / Width / Depth		mm		1480		402	
Net Weight		kg		22.0		-	
Shipping Weight		kg		30.0		-	
Connector Type				4.3-10 female			
Connector Quantity				6			
Connector Partition				bottom			
Survival Wind Speed		km/h		250			
Radome Material				GFK			
Radome Color				RAL 7035			
Mechanical Distance between Mounting Points - Ref. 1		mm		1301			
Mechanical Distance between Mounting Points - Ref. 2		mm		1302			
Lightning Protection				dc grounded			
Environmental Specifications							
Storage		Standard		ETSI EN 300 019-1-1		Class 1.1	
Transportation		Standard		ETSI EN 300 019-1-2		Class 2.1	
Environmental conditions		Standard		ETSI EN 300 019-1-4		Class 4.1E	
Packaged Storage		Standard		ETSI EN 300 019-1-1		Class 1.1	
Product Environmental compliance		Standard		RoHS		EN50518:2012	
Additional Fields							
Compatible RETr				999999V01;999999V10			
Vendor comment				Mounting hardware included in the package; integrated RETr included			

APPENDIX C – LOGICAL BLOCK STRUCTURE (ANTENNA+RET)

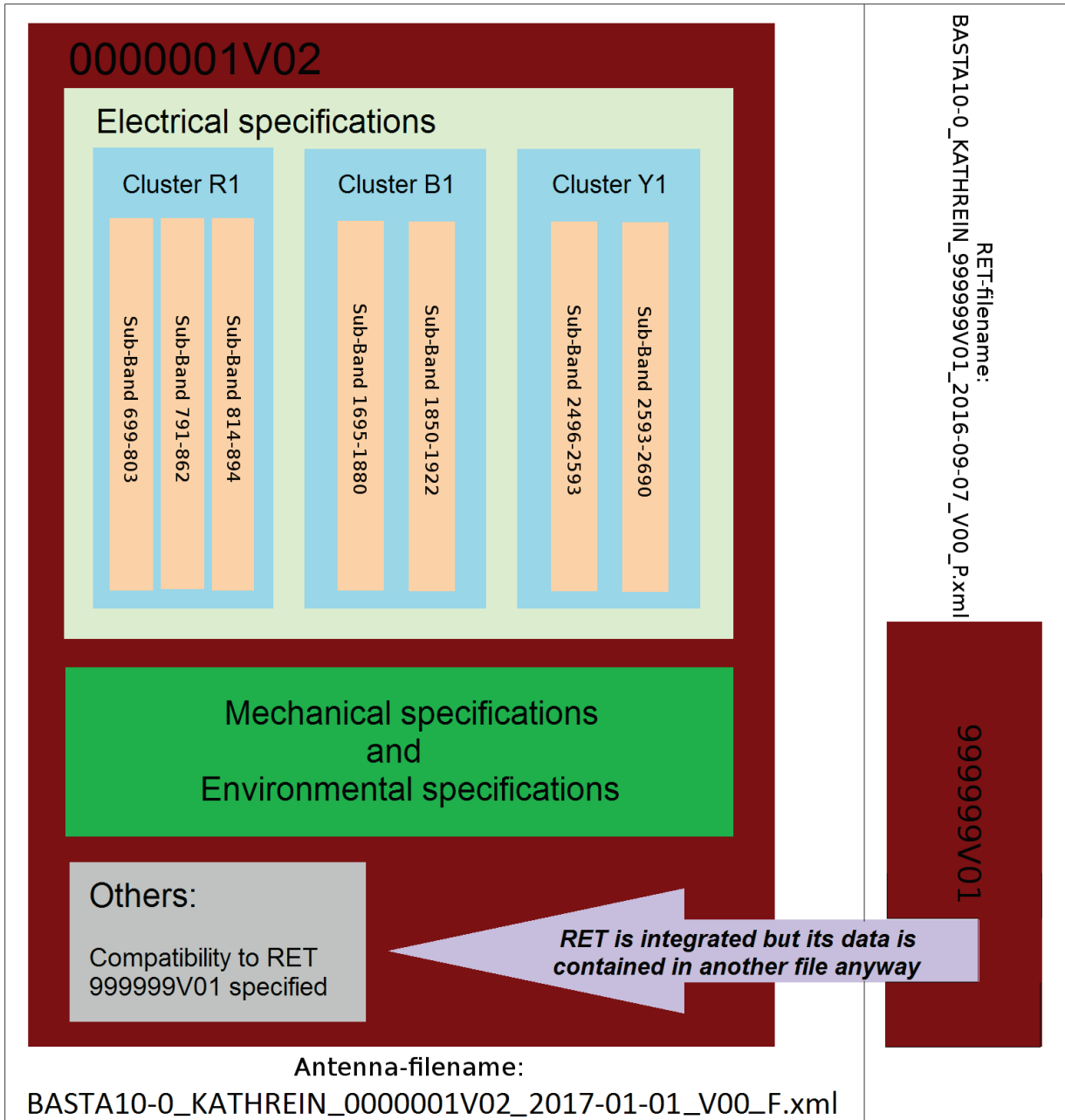

APPENDIX D – EXAMPLE OF ANTENNA XML FILE

```

<?xml version="1.0" encoding="UTF-8"?>
<basta version="10.0">
  <annotation> Yet another useful comment </annotation>

  <antenna vendor="KATHREIN" model="0000001V02"
    description="XXXPol Panel 699-894/1695-1922/2496-2690 65°/65°/65° 15/17/17dBi 2°-16°/2.5°-12°/2.5°-12°T">

    <replacement_datasheet datasheet="BASTA10-0_KATHREIN_0000001V02_1999-12-04_V11_F"/>

    <electrical_specifications>

      <maximum_effective_power_antenna value="1000"/>

      <cluster name="R1">

        <port name="1" polarization="+45" connector_type="7-16" location="bottom"/>
        <port name="2" polarization="-45" connector_type="7-16" location="bottom"/>
        <frequency_range start="699" stop="894"/>
        <mechanical_boresight value="0"/>
        <nominal_horizontal_half_power_beamwidth value="65"/>
        <electrical_downtilt start="2.0" stop="16.0"/>
        <isolation_interband value="30"/>
        <impedance value="50"/>
        <vswr value="1.5"/>
        <return_loss value="14"/>
        <passive_intermodulation value="-150"/>
        <maximum_effective_power_per_port value="300"/>
        <maximum_effective_power_cluster value="600"/>

        <frequency_sub_range start="699" stop="803">
          <gain_at_tilt min="14.0" mid="14.2" max="13.9"/>
          <gain_over_all_tilts value="14.1" tolerance="2.6"/>
          <azimuth_interference_ratio value="5.4" tolerance="0.2"/>
          <azimuth_beamwidth value="65.0" tolerance="3.5"/>
          <azimuth_beam_squint value="1.4" tolerance="2.8"/>
          <azimuth_beam_port_to_port_tracking value="1.3"/>
          <azimuth_beam_hv_tracking value="1.6"/>
          <azimuth_beam_roll_off value="1.2" tolerance="2.7"/>
          <elevation_beamwidth value="14.1" tolerance="1.2"/>
          <elevation_downtilt_deviation value="0.6"/>
          <front_to_back_ratio_total_power_pm30 value="21.7"/>
          <front_to_back_ratio_over_30_angular_region_total_power_az_and_el value="12.1"/>
          <null_fill value="33.9"/>
          <upper_sidelobe_suppression_first value="9999.9" applicable="false"/>
          <upper_sidelobe_suppression_peak_to_20 value="13.7"/>
          <upper_sidelobe_suppression_horizon_to_20 value="12.3"/>
          <upper_sidelobe_suppression_maximum_level value="7.0"/>
          <cross_polar_discrimination_over_sector value="8.7"/>
          <cross_polar_discrimination_at_mechanical_boresight value="21.0"/>
          <cross_polar_discrimination_over_3_db_azimuth_beamwidth value="13.1"/>
          <cross_polar_discrimination_over_10_db_azimuth_beamwidth value="5.0"/>
          <cross_polar_discrimination_over_3_db_elevation_beamwidth value="26.9"/>
          <cross_polar_discrimination_over_10_db_elevation_beamwidth value="19.9"/>
          <isolation_cross_polar value="28"/>
        </frequency_sub_range>
      </cluster>
    </electrical_specifications>
  </antenna>
</basta>

```

```

<frequency_sub_range start="791" stop="862">
  <gain_at_tilt min="14.0" mid="14.8" max="14.8"/>
  <gain_over_all_tilts value="14.9" tolerance="5.3"/>
  <azimuth_interference_ratio value="5.2" tolerance="0.6"/>
  <azimuth_beamwidth value="63.0" tolerance="3.8"/>
  <azimuth_beam_squint value="1.0" tolerance="2.1"/>
  <azimuth_beam_port_to_port_tracking value="1.3"/>
  <azimuth_beam_hv_tracking value="1.6"/>
  <azimuth_beam_roll_off value="1.1" tolerance="2.1"/>
  <elevation_beamwidth value="14.1" tolerance="1.1"/>
  <elevation_downtilt_deviation value="0.5"/>
  <front_to_back_ratio_total_power_pm30 value="23.2"/>
  <front_to_back_ratio_over_30_angular_region_total_power_az_and_el value="17.1"/>
  <null_fill value="32.6"/>
  <upper_sidelobe_suppression_first value="9999.9" applicable="false"/>
  <upper_sidelobe_suppression_peak_to_20 value="14.5"/>
  <upper_sidelobe_suppression_horizon_to_20 value="13.8"/>
  <upper_sidelobe_suppression_maximum_level value="7.4"/>
  <cross_polar_discrimination_over_sector value="7.8"/>
  <cross_polar_discrimination_at_mechanical_boresight value="23.2"/>
  <cross_polar_discrimination_over_3_db_azimuth_beamwidth value="13.4"/>
  <cross_polar_discrimination_over_10_db_azimuth_beamwidth value="6.1"/>
  <cross_polar_discrimination_over_3_db_elevation_beamwidth value="25.8"/>
  <cross_polar_discrimination_over_10_db_elevation_beamwidth value="19.7"/>
  <isolation_cross_polar value="28"/>
</frequency_sub_range>

<frequency_sub_range start="814" stop="894">
  <gain_at_tilt min="14.7" mid="15.0" max="15.0"/>
  <gain_over_all_tilts value="14.8" tolerance="5.0"/>
  <azimuth_interference_ratio value="5.0" tolerance="0.3"/>
  <azimuth_beamwidth value="62.6" tolerance="2.7"/>
  <azimuth_beam_squint value="0.4" tolerance="2.8"/>
  <azimuth_beam_port_to_port_tracking value="1.6"/>
  <azimuth_beam_hv_tracking value="1.6"/>
  <azimuth_beam_roll_off value="0.7" tolerance="2.2"/>
  <elevation_beamwidth value="13.9" tolerance="0.8"/>
  <elevation_downtilt_deviation value="0.4"/>
  <front_to_back_ratio_total_power_pm30 value="23.8"/>
  <front_to_back_ratio_over_30_angular_region_total_power_az_and_el value="15.4"/>
  <null_fill value="28.9"/>
  <upper_sidelobe_suppression_first value="9999.9" applicable="false"/>
  <upper_sidelobe_suppression_peak_to_20 value="13.3"/>
  <upper_sidelobe_suppression_horizon_to_20 value="13.1"/>
  <upper_sidelobe_suppression_maximum_level value="6.9"/>
  <cross_polar_discrimination_over_sector value="7.8"/>
  <cross_polar_discrimination_at_mechanical_boresight value="23.5"/>
  <cross_polar_discrimination_over_3_db_azimuth_beamwidth value="13.4"/>
  <cross_polar_discrimination_over_10_db_azimuth_beamwidth value="5.9"/>
  <cross_polar_discrimination_over_3_db_elevation_beamwidth value="23.3"/>
  <cross_polar_discrimination_over_10_db_elevation_beamwidth value="19.1"/>
  <isolation_cross_polar value="28"/>
</frequency_sub_range>
</cluster>

```

```

<cluster name="B1">

  <port name="3" polarization="+45" connector_type="7-16" location="bottom"/>
  <port name="4" polarization="-45" connector_type="7-16" location="bottom"/>
  <frequency_range start="1695" stop="1922"/>
  <mechanical_boresight value="0"/>
  <nominal_horizontal_half_power_beamwidth value="65"/>
  <electrical_downtilt start="2.5" stop="12.0"/>
  <isolation_interband value="30"/>
  <impedance value="50"/>
  <vswr value="1.5"/>
  <return_loss value="14"/>
  <passive_intermodulation value="-150"/>
  <maximum_effective_power_per_port value="300"/>
  <maximum_effective_power_cluster value="600"/>

  <frequency_sub_range start="1695" stop="1880">
    <gain_at_tilt min="16.7" mid="16.7" max="16.0"/>
    <gain_over_all_tilts value="16.0" tolerance="6.0"/>
    <azimuth_interference_ratio value="4.9" tolerance="1.2"/>
    <azimuth_beamwidth value="63.5" tolerance="5.0"/>
    <azimuth_beam_squint value="-0.5" tolerance="3.0"/>
    <azimuth_beam_port_to_port_tracking value="2.0"/>
    <azimuth_beam_hv_tracking value="1.7"/>
    <azimuth_beam_roll_off value="0.8" tolerance="1.9"/>
    <elevation_beamwidth value="11.0" tolerance="0.6"/>
    <elevation_downtilt_deviation value="0.3"/>
    <front_to_back_ratio_total_power_pm30 value="24.0"/>
    <front_to_back_ratio_over_30_angular_region_total_power_az_and_el value="13.9"/>
    <null_fill value="40.5"/>
    <upper_sidelobe_suppression_first value="15.9"/>
    <upper_sidelobe_suppression_peak_to_20 value="14.2"/>
    <upper_sidelobe_suppression_horizon_to_20 value="13.9"/>
    <upper_sidelobe_suppression_maximum_level value="8.2"/>
    <cross_polar_discrimination_over_sector value="9.2"/>
    <cross_polar_discrimination_at_mechanical_boresight value="15.7"/>
    <cross_polar_discrimination_over_3_db_azimuth_beamwidth value="16.8"/>
    <cross_polar_discrimination_over_10_db_azimuth_beamwidth value="5.7"/>
    <cross_polar_discrimination_over_3_db_elevation_beamwidth value="30.1"/>
    <cross_polar_discrimination_over_10_db_elevation_beamwidth value="18.0"/>
    <isolation_cross_polar value="28"/>
  </frequency_sub_range>

```

```

<frequency_sub_range start="1850" stop="1922">
  <gain_at_tilt min="17.0" mid="17.0" max="16.8"/>
  <gain_over_all_tilts value="16.9" tolerance="5.0"/>
  <azimuth_interference_ratio value="4.9" tolerance="1.3"/>
  <azimuth_beamwidth value="60.0" tolerance="2.4"/>
  <azimuth_beam_squint value="-0.3" tolerance="2.4"/>
  <azimuth_beam_port_to_port_tracking value="2.3"/>
  <azimuth_beam_hv_tracking value="2.0"/>
  <azimuth_beam_roll_off value="1.3" tolerance="1.5"/>
  <elevation_beamwidth value="9.0" tolerance="0.7"/>
  <elevation_downtilt_deviation value="0.2"/>
  <front_to_back_ratio_total_power_pm30 value="25.6"/>
  <front_to_back_ratio_over_30_angular_region_total_power_az_and_el value="18.7"/>
  <null_fill value="38.2"/>
  <upper_sidelobe_suppression_first value="15.9"/>
  <upper_sidelobe_suppression_peak_to_20 value="16.3"/>
  <upper_sidelobe_suppression_horizon_to_20 value="15.2"/>
  <upper_sidelobe_suppression_maximum_level value="7.4"/>
  <cross_polar_discrimination_over_sector value="9.6"/>
  <cross_polar_discrimination_at_mechanical_boresight value="20.6"/>
  <cross_polar_discrimination_over_3_db_azimuth_beamwidth value="18.1"/>
  <cross_polar_discrimination_over_10_db_azimuth_beamwidth value="5.5"/>
  <cross_polar_discrimination_over_3_db_elevation_beamwidth value="29.7"/>
  <cross_polar_discrimination_over_10_db_elevation_beamwidth value="18.0"/>
  <isolation_cross_polar value="28"/>
</frequency_sub_range>

</cluster>

<cluster name="Y1">

  <port name="5" polarization="+45" connector_type="7-16" location="bottom"/>
  <port name="6" polarization="-45" connector_type="7-16" location="bottom"/>
  <frequency_range start="2496" stop="2690"/>
  <mechanical_boresight value="0"/>
  <nominal_horizontal_half_power_beamwidth value="65"/>
  <electrical_downtilt start="2.5" stop="12.0"/>
  <isolation_interband value="30"/>
  <impedance value="50"/>
  <vswr value="1.5"/>
  <return_loss value="14"/>
  <passive_intermodulation value="-150"/>
  <maximum_effective_power_per_port value="300"/>
  <maximum_effective_power_cluster value="600"/>

```

```

<frequency_sub_range start="2496" stop="2593">
  <gain_at_tilt min="16.8" mid="17.0" max="16.8"/>
  <gain_over_all_tilts value="17.0" tolerance="7.1"/>
  <azimuth_interference_ratio value="3.2" tolerance="0.9"/>
  <azimuth_beamwidth value="61.5" tolerance="6.0"/>
  <azimuth_beam_squint value="-2.0" tolerance="2.0"/>
  <azimuth_beam_port_to_port_tracking value="1.7"/>
  <azimuth_beam_hv_tracking value="1.1"/>
  <azimuth_beam_roll_off value="0.8" tolerance="1.2"/>
  <elevation_beamwidth value="6.0" tolerance="0.3"/>
  <elevation_downtilt_deviation value="0.2"/>
  <front_to_back_ratio_total_power_pm30 value="25.7"/>
  <front_to_back_ratio_over_30_angular_region_total_power_az_and_el value="10.1"/>
  <null_fill value="36.9"/>
  <upper_sidelobe_suppression_first value="16.8"/>
  <upper_sidelobe_suppression_peak_to_20 value="15.5"/>
  <upper_sidelobe_suppression_horizon_to_20 value="12.6"/>
  <upper_sidelobe_suppression_maximum_level value="7.3"/>
  <cross_polar_discrimination_over_sector value="10.0"/>
  <cross_polar_discrimination_at_mechanical_boresight value="15.5"/>
  <cross_polar_discrimination_over_3_db_azimuth_beamwidth value="11.7"/>
  <cross_polar_discrimination_over_10_db_azimuth_beamwidth value="6.7"/>
  <cross_polar_discrimination_over_3_db_elevation_beamwidth value="25.5"/>
  <cross_polar_discrimination_over_10_db_elevation_beamwidth value="18.4"/>
  <isolation_cross_polar value="28"/>
</frequency_sub_range>

<frequency_sub_range start="2593" stop="2690">
  <gain_at_tilt min="16.8" mid="17.0" max="17.1"/>
  <gain_over_all_tilts value="17.0" tolerance="7.1"/>
  <azimuth_interference_ratio value="4.7" tolerance="0.8"/>
  <azimuth_beamwidth value="61.3" tolerance="6.0"/>
  <azimuth_beam_squint value="-2.1" tolerance="2.7"/>
  <azimuth_beam_port_to_port_tracking value="2.0"/>
  <azimuth_beam_hv_tracking value="1.2"/>
  <azimuth_beam_roll_off value="0.8" tolerance="1.2"/>
  <elevation_beamwidth value="4.9" tolerance="0.1"/>
  <elevation_downtilt_deviation value="0.2"/>
  <front_to_back_ratio_total_power_pm30 value="26.0"/>
  <front_to_back_ratio_over_30_angular_region_total_power_az_and_el value="9.5"/>
  <null_fill value="36.6"/>
  <upper_sidelobe_suppression_first value="17.0"/>
  <upper_sidelobe_suppression_peak_to_20 value="15.5"/>
  <upper_sidelobe_suppression_horizon_to_20 value="11.6"/>
  <upper_sidelobe_suppression_maximum_level value="7.4"/>
  <cross_polar_discrimination_over_sector value="10.0"/>
  <cross_polar_discrimination_at_mechanical_boresight value="15.2"/>
  <cross_polar_discrimination_over_3_db_azimuth_beamwidth value="11.9"/>
  <cross_polar_discrimination_over_10_db_azimuth_beamwidth value="6.9"/>
  <cross_polar_discrimination_over_3_db_elevation_beamwidth value="25.6"/>
  <cross_polar_discrimination_over_10_db_elevation_beamwidth value="18.2"/>
  <isolation_cross_polar value="28"/>
</frequency_sub_range>
</cluster>

```

```
</electrical_specifications>

<mechanical_specifications>
  <antenna_dimensions height="1250" width = "378" depth="144" reference="H"/>
  <packing_size height="1480" width="402" depth="240"/>
  <net_weight wo_mtg_hardware="22.0" only_mtg_hardware="2.0"/>
  <shipping_weight value="30.0"/>
  <survival_wind_speed value="250"/>
  <radome_material value="GFK"/>
  <radome_color value="RAL 7035"/>
  <lightning_protection value="yes"/>
  <mechanical_distance_between_mounting_points_antenna value="1301"/>
  <product_environmental_compliance_general standard="RoHS" compliance="EN50581:2012"/>
  <product_environmental_compliance_transportation standard="ETS EN 300 019-1-2" compliance="Class 2.1"/>
  <product_environmental_compliance_environmental_conditions standard="ETS EN 300 019-1-4" compliance="Class 4.1 E"/>
  <product_environmental_compliance_storage standard="ETS EN 300 019-1-1" compliance="Class 1.1"/>
  <product_environmental_compliance_packed_storage standard="ETS EN 300 019-1-1" compliance="Class 1.1"/>
</mechanical_specifications>

<miscellaneous_data>
  <compatible_ret value="999999V01 ; 999998V10"/>
  <vendor_comments value="Mounting hardware included in the package ; integrated RET included ;
    distance m.points-pole with clamps = 1000 ; distance m.points-pole with tension bands = 900"/>
</miscellaneous_data>

</antenna>

</basta>
```

APPENDIX E – EXAMPLE OF RET XML FILE

```

<?xml version="1.0" encoding="UTF-8"?>
<basta version="10.0">
  <annotation> Hello World! </annotation>
  <ret vendor_name="KATHREIN" vendor_ret_type="999999V01">
    <replacement_datasheet datasheet="BASTA10-0_KATHREIN_999999V01_1999-12-30_V01_F"/>
    <standalone_dimensions height="130" width="40" depth="21"/>
    <installed_dimensions height="100" width="40" depth="21" reference="H"/>
    <working_temperature_range min="-40" max="60"/>
    <power_consumption low_power="1" high_power="10"/>
    <lose_position_on_power_failure value="true"/>
    <compatible_standards value="3GPP/AISG 2.0 ; Aisg v1.1"/>
    <compatible_protocols value="Eric Proprietary ; NOK"/>
    <configuration_management value="integrated ret, automatically configured"/>
    <antenna_configuration_file_available value="false"/>
    <antenna_configuration_file_upgradable value="no"/>
    <software_upgradable value="yes, by base station and proprietary portable controller"/>
    <field_replacement_allowed value="yes, without removing antenna"/>
    <visual_indicator_available_on_tilt_change value="true"/>
    <daisy_chain_available value="true"/>
  </ret>
</basta>

```

APPENDIX F – GLOSSARY

- 3GPP – 3rd Generation Partnership Project
- AIR – Azimuth Interference Ratio
- AUT – Antenna Under Test
- AZ – AZimuth
- BSA – Base Station Antennas
- Co-Pol – Co-Polar
- CPD (or XPD) – Cross-Polar Discrimination (see: CPR)
- CPI – Cross-Polar Isolation
- CPR – Cross-Polar Ratio (see: CPD)
- Cr-Pol (or X-Pol) – Cross-Polar
- CW – Continuous Wave
- DL – DownLink
- E-UTRA – Evolved UMTS Terrestrial Radio Access
- EL – Elevation
- ETSI – European Telecommunications Standards Institute
- F/B or FBR or F2B – Front-to-Back ratio
- FF – Far Field
- FFT – Fast Fourier Transform
- FDD – Frequency Division Duplex
- H_HP BW – Horizontal HPBW
- HPBW – Half-Power BeamWidth
- IEC – International Electrotechnical Commission
- LHCP – Left-Handed Circular Polarization (or Circularly Polarized)
- MIMO – Multiple Input / Multiple Output
- MTBF – Mean Time Between Failures
- N/A or n/a – Not Available
- NF – Near Field
- NGMN – Next Generation Mobile Networks alliance
- OEWG – Open-Ended WaveGuide
- P-BASTA – Project BAse STation Antennas
- PIM – Passive InterModulation
- QoS – Quality of Service
- R&D – Research and Development
- RET – Remote Electrical Tilt
- RF – Radio Frequency
- RFQ – Request For Quotation
- RHCP – Right-Handed Circular Polarization (or Circularly Polarized)
- RL – Return Loss
- SLS – SideLobe Suppression
- TDD – Time Division Duplex
- TEM – Transverse Electric and Magnetic
- UL – UpLink
- UMTS – Universal Mobile Telecommunications System
- USLS – Upper SideLobe Suppression
- V_HP BW – Vertical HPBW
- VNA – Vector Network Analyzer
- VSWR – Voltage Standing Wave Ratio
- XML – eXtensible Markup Language